

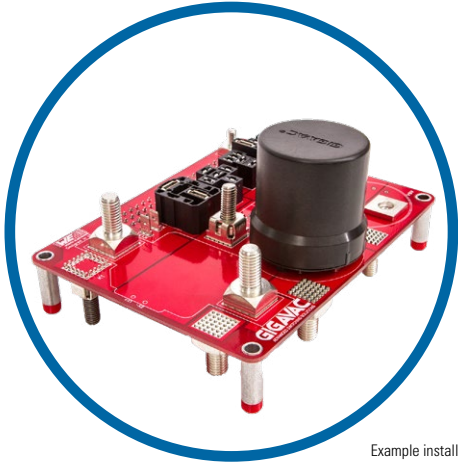

## GV14 Series

400+ AMP 100 VDC CONTACTOR



Example installation shown.  
PCB not included.

### Features

- PCB mountable option allows lowest cost OEM solution by eliminating need for cables, wires and connector.
- Hermetically Sealed – Designed to meet: UL1604 for Class I & II, Div 2 and Class III for use in hazardous locations, IP67 for temporary water immersion for 30 min, SAE J1171 - external ignition protection, and ISO8846 for protection against ignition around flammable gasses.
- Meets CE Conformance standards.
- Built-in coil suppression for all DC coils – Saves you engineering time and parts cost to add external coil suppression.
- Stainless steel hardware and brass mounting inserts, for years of corrosion free service.
- Not position sensitive – can be mounted in any position for ease of installation.



## SPECIFICATIONS

Specifications		Units	Data
Rated Voltage		V	100
Contact Arrangement	Main	Form X	SPST-NO
	Auxiliary <sup>1</sup>	Form A or B	SPST-NO or SPST-NC
Mechanical Life		cycles	1,000,000
Contact Resistance	Max	mohms	0.4
	Typical	mohms	0.3
Insulation Resistance <sup>2</sup>		Mohms	100
Dielectric at sea level (leakage < 1mA)		VRMS	4000
Shock, 1/2 Sine, 11ms	Actuated (closed)	G	50
	Non Actuated (open)	G	25
Vibration, Sinusoidal (10-2000 Hz peak)		G	25
Environmental Seal		Exceeds IP67 & IP69K	
Salt Fog		MIL-STD-810	
Temperature	Operating ambient Temp Range	-55 to +85°C <sup>5</sup>	
	Storage ambient Temp Range	-70 to +150°C	
Weight, typical	Upright Mount	0.44 kg (0.97 lb)	
	Side Mount	0.45 kg (0.99 lb)	
	PCB Mount	0.38 kg (0.84 lb)	
Packaging		24 units per shipping box 21 in x 18 in x 4 in shipping box	

## Coil Ratings at 25°C

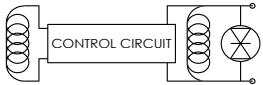
Coil P/N Designation	B <sup>8</sup>	C <sup>8</sup>	F <sup>8</sup>	M	N	P	Q
Coil Voltage, Nominal (VDC)	12	24	48	12/24	48	12/24	48
Coil Type	Dual	Dual	Dual	PWM	PWM	External PWM <sup>4</sup>	External PWM <sup>4</sup>
Coil Voltage, Max (V)	16	32	64	36	95		
Pick-Up Voltage, Max (V) <sup>5,6,7</sup>	8	16	40	8.5	32		
Drop-Out Voltage, Max (V) <sup>5</sup>	0.5	2	4	6.5	20		
Pick-Up Current, Max (A) (75 ms) <sup>5,6</sup>	3.9	1.6	0.97	3.6	0.9		
Coil Current (A) <sup>5</sup>	0.23	0.097	0.042	0.13A @12VDC 0.07A @24VDC	0.04A @48VDC		
Coil Power (W) <sup>5</sup>	2.8	2.3	2	1.7	1.9		
Operate Time, Max (ms) <sup>10</sup>	20	20	20	25	25	20	20
Release Time, Max (ms)	12						
Internal Coil Suppression	TVS 			N/A			
Coil Back EMF (V)	55	55	125	0	0		
Transients, Max (V) (13 ms)	±50	±50	±75	±60	±100		
Reverse Polarity (V)	16	32	64	100	100		



## POWER SWITCHING

### DC POWER SWITCHING CYCLES

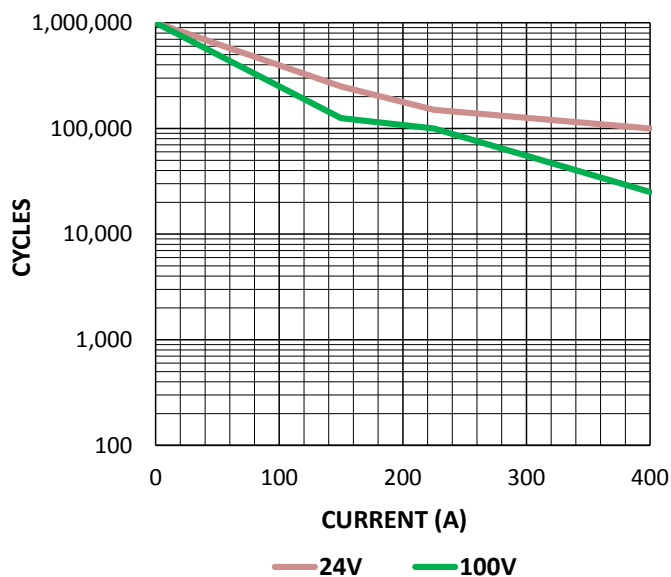

## CURRENT CARRY RATINGS

### CURRENT CARRY vs TIME with 85°C terminal temperature rise

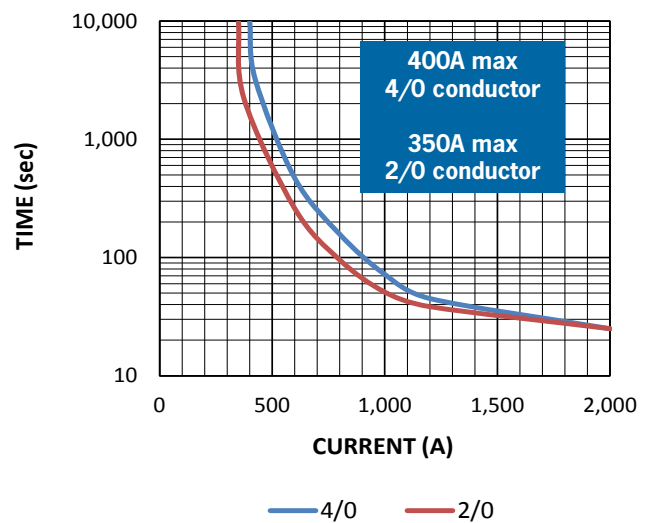

### Auxiliary contacts (optional)

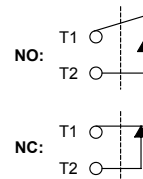

### Power Contacts

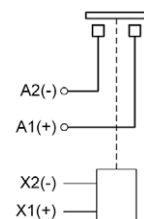



## UPRIGHT MOUNT DIMENSIONS

All dimensions are +/- 0.5mm unless stated otherwise

### Upright Mount

#### Auxiliary Leads

B=SPST-NO  
Blue Lead = T1  
White Lead = T2  
C=SPST-NC  
Orange Lead = T1  
White Lead = T2

#### Coil Leads

Red Lead = X1(+)  
Black Lead = X2(-)

#### Upright Mounting

M5 or No. 10 Screws  
Torque 1.7-4 Nm [15-35 in-lb]

#### Upright Mount Power Connection

Silver Plated Copper M8x1.25 stud  
Stainless M8x1.25 flanged nut  
Torque 10 Nm [90 in-lb] max

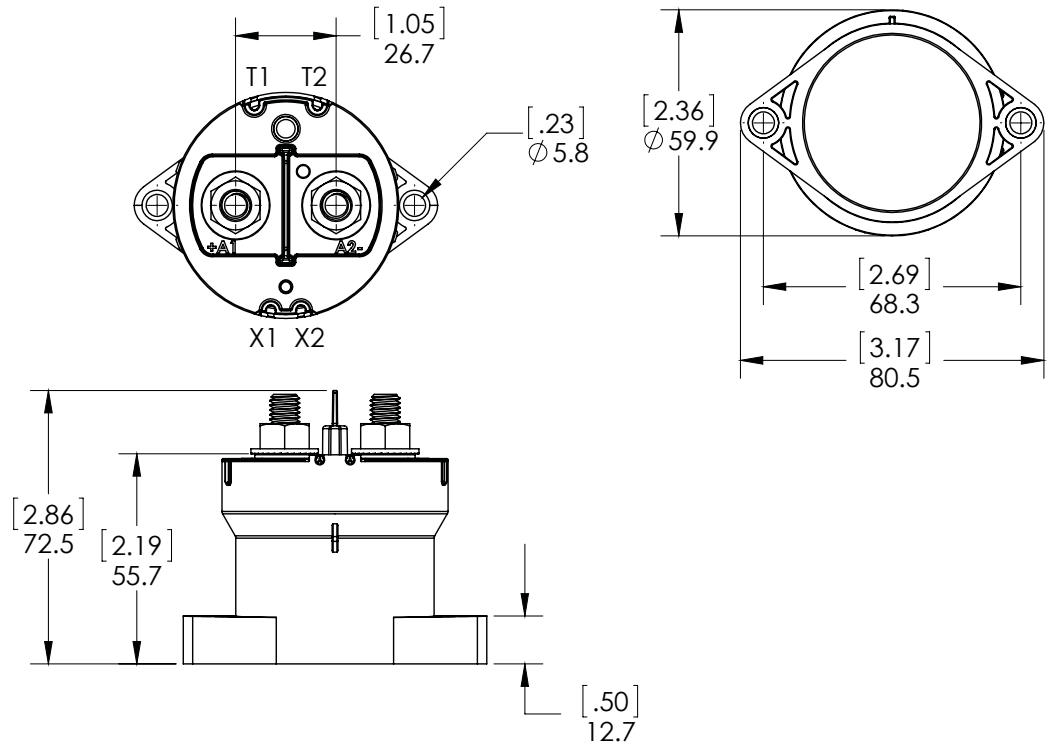

## SIDE MOUNT DIMENSIONS

#### Auxiliary Leads

B=SPST-NO  
Blue Lead = T1  
White Lead = T2  
C=SPST-NC  
Orange Lead = T1  
White Lead = T2

#### Coil Leads

Red Lead = X1(+)  
Black Lead = X2(-)

#### Side Mounting

M5 or No. 10 Screws  
Torque 1.7-4 Nm [15-35 in-lb]

#### Side Mount Power Connection

Silver Plated Copper M8x1.25 stud  
Stainless M8x1.25 flanged nut  
Torque 10 Nm [90 in-lb] max

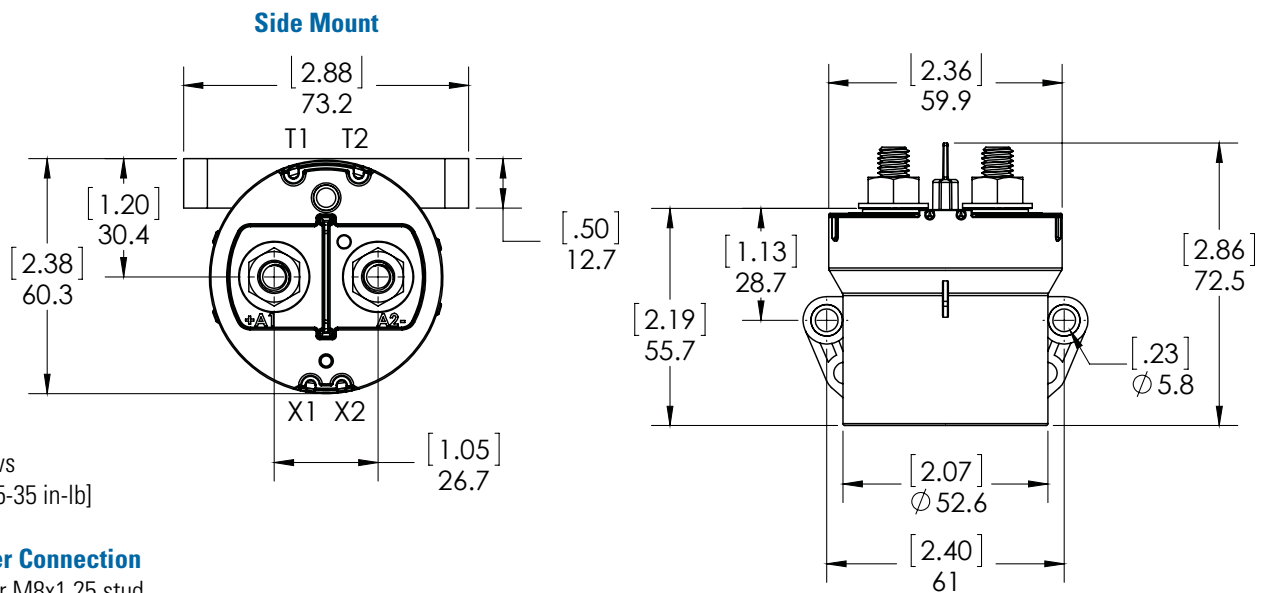



# PCB MOUNT DIMENSIONS

## PCB Mount

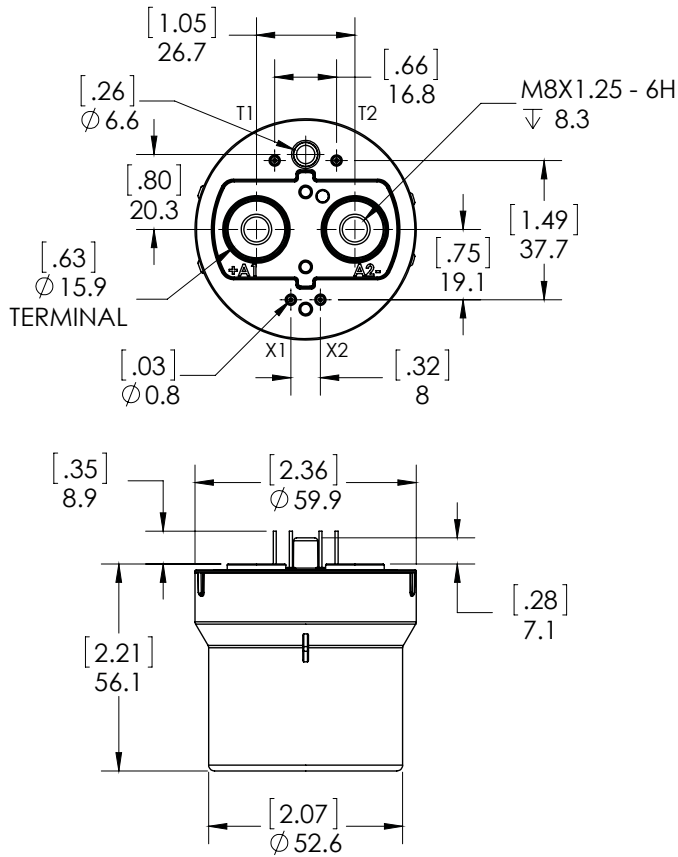

## PCB Mount with Barrier

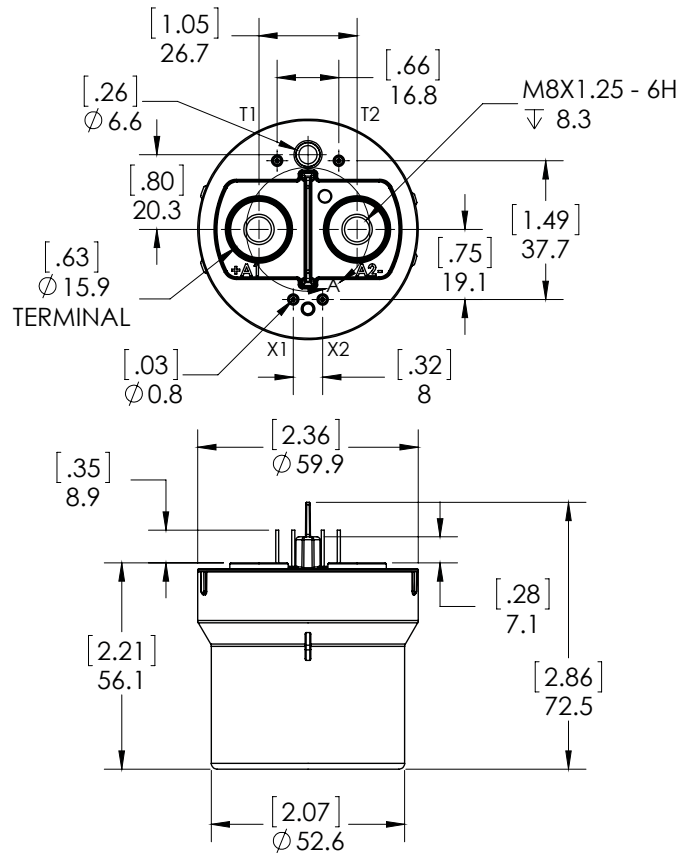

### PCB Mounting / Power Connection

M8x1.25 bolt  
Torque 10 Nm [90 in-lb] max

### PCB Coil and Auxiliary Pin Material

510 Phosphor Bronze, Tin Plated

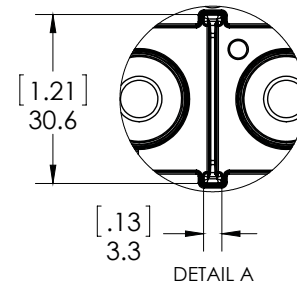



## ORDERING OPTIONS

Example : GV141BAB

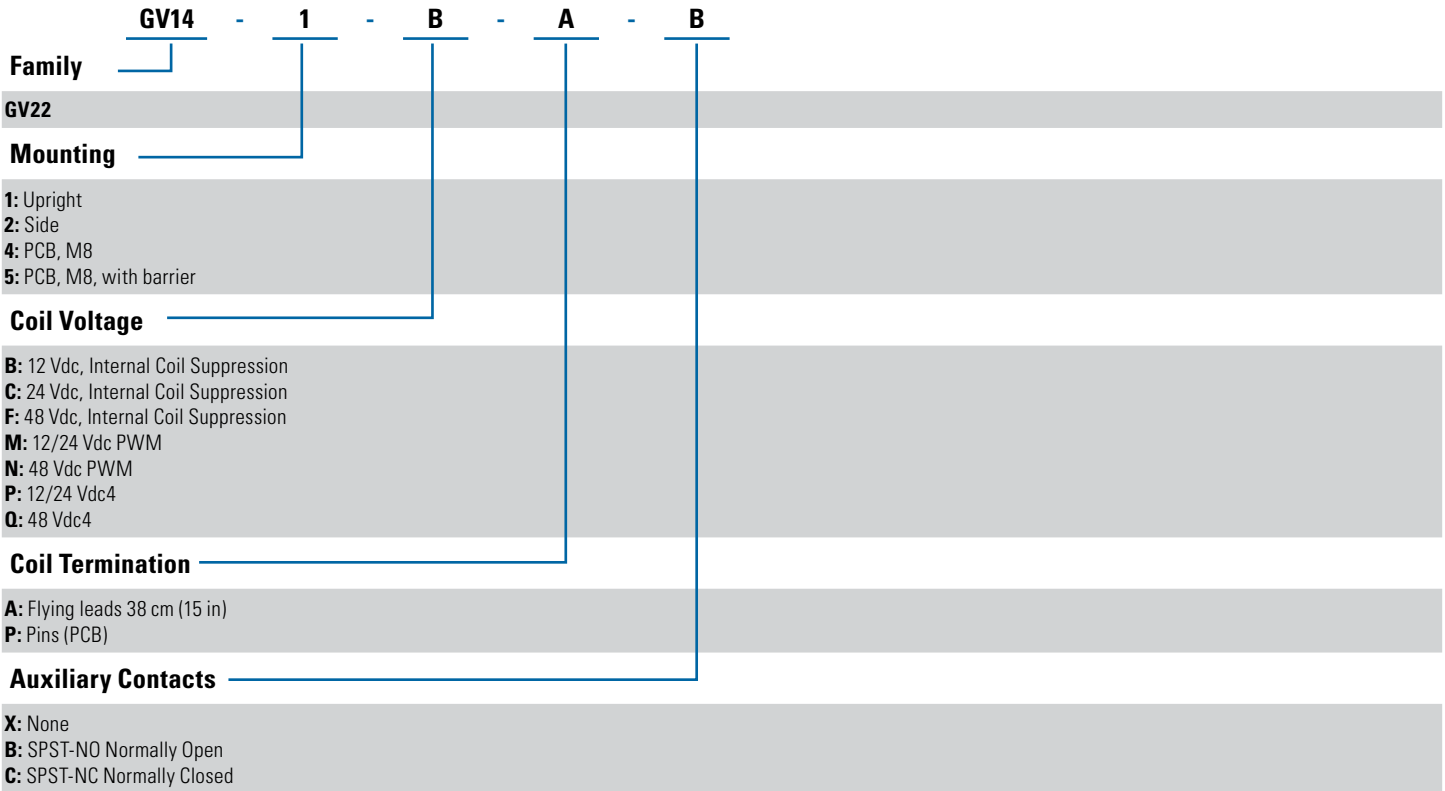

## GENERAL NOTES

1. Auxillary contact rating is 2A, 24Vdc Resistive load, 100,000 cycles. Minimum current is 0.1mA, 5V. The auxiliary contact is mechanically linked to the main power-contacts.
2. Insulation resistance is 50 Mohms at contactor end-of-life.
3. Contactor can operate up to 125°C in special cases - contact GIGAVAC for details.
4. Customer must provide an external economizer that meets the Pick-up Current, Coil Current, and Pick-up Current Time. For detailed information click here Application Note AN-016 or visit [www.gigavac.com/application-notes](http://www.gigavac.com/application-notes).
5. Because the contactor is operated by a coil that changes resistance with temperature:  
Maximum coil voltage will be lower than indicated at temperatures above 25°C and higher than indicated at temperatures below 25°C.  
And because Nominal Coil Voltage has been assumed for the Pick-up Current, Coil Current and Coil Power specifications, Current/Wattage will be lower than indicated at temperatures above 25°C and higher than indicated at temperatures below 25°C.  
Pick-up Voltage and Drop Out Voltage will be lower than indicated at temperatures below 25°C and higher than indicated at temperatures above 25°C.
6. Contactor has two coils. Both are used for pick-up, and then in approximately 75 milliseconds, one coil is electronically removed from the coil drive circuit. The remaining coil supplies low continuous hold power sufficient for the contactor to meet all of its specified performance specifications. This provides the lowest coil power possible without the use of PWM electronics that have been known to cause EMI emissions and/or cross-talk on your system control power.
7. For Pick-up testing of contactors with dual coils, the voltage can not be ramped up slowly, but must be applied instantly to at least the maximum Pick-up Voltage or Current. Otherwise, the contactor will not pick-up.