

Description

The GX36220 is a dual-channel 64Gbps linear Trans-Impedance Amplifier (TIA) for 400G/600G Integrated Coherent Receivers (ICRs).

The GX36220 integrates two TIA signal paths for I and Q channels. The high-performance, low power, and compact design of the GX36220 also enables a small-form factor integrated optical module such as CFP2 and CFP4.

Typical Applications

- 400G/600G coherent systems with 64Gbps 16QAM/64QAM modulation format
- Integrated optical modules for CFP/CFP2/CFP4 form factors

Features

- Dual-channel integrated 64Gbps linear TIA with analog control interface
- Differential linear gain: 150–5,000Ω, and > 30dB dynamic range
- > 40 GHz 3dB-bandwidth and adjustable bandwidth
- Automatic and manual gain control, Output Voltage Control, Peak Detection and Shutdown functionalities
- Low THD, cross talk, and power consumption for covering 64QAM receiver

Block Diagram

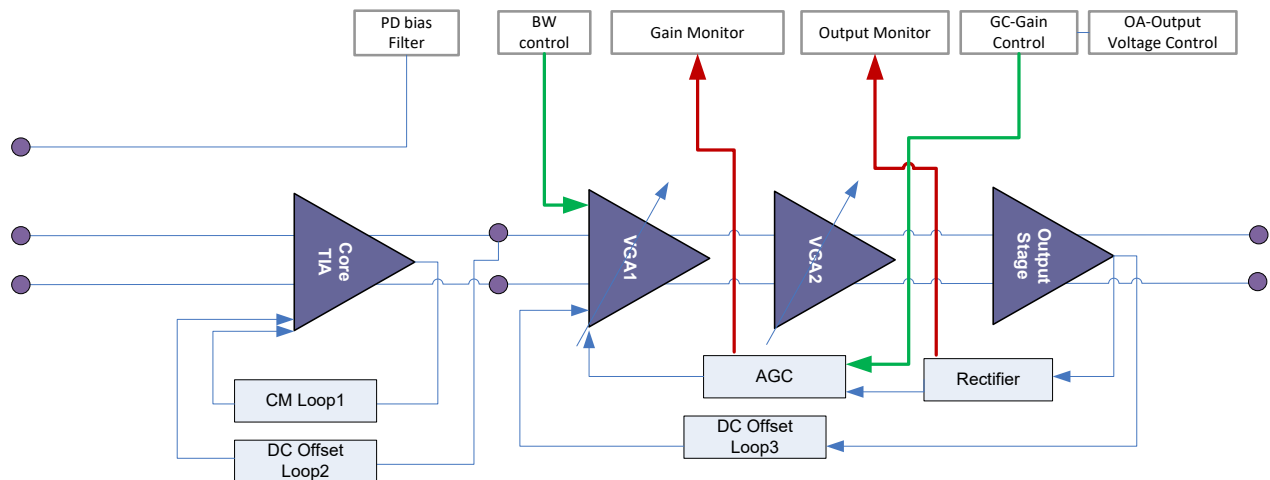

Figure 1: Block Diagram

