

6 PIN DIP SCHMITT TRIGGER PHOTOCOUPLER H11LX Series

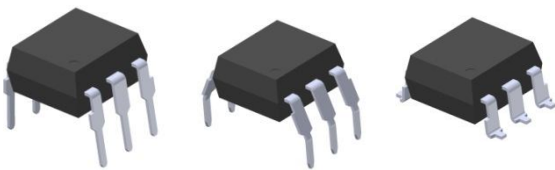

Features:

- High data rate, 1MHz typical (NRZ)
- Free from latch up and oscillation throughout voltage and temperature ranges.
- Microprocessor compatible drive
- Logic compatible output sinks 16mA at 0.4V maximum
- Guaranteed on/off threshold hysteresis
- Wide supply voltage capability, compatible with all popular logic systems
- High isolation voltage between input and output (Viso=5000 V rms)
- Compact dual-in-line package
- The product itself will remain within RoHS compliant version
- Compliance with EU REACH
- UL and cUL approved(No. E214129)
- VDE approved (No. 132249)
- SEMKO approved
- NEMKO approved
- DEMKO approved
- FIMKO approved
- CQC approved

Schematic

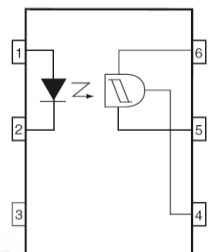

Pin Configuration

1. Anode
2. Cathode
3. No Connection
4. V_O
5. GND
6. V_{Cc}

Truth Table

Input	Output
H	L
L	H

Description

The H11LX series of devices each consist of a GaAs infrared emitting diode optically coupled a high speed integrated circuit detector. The output detector incorporates a Schmitt trigger, which provides hysteresis for noise immunity and pulse shaping.

The devices are in a 6-pin DIP package and available in wide-lead spacing and SMD option.

Applications

- Logic to logic isolator
- Programmable current level sensor
- Line receiver — eliminate noise and transient problems
- AC to TTL conversion — square wave shaping
- Digital programming of power supplies
- Interfaces computers with peripherals

Absolute Maximum Ratings (Ta=25°C)

	Parameter	Symbol	Rating	Unit
Input	Forward current	I_F	60	mA
	Reverse voltage	V_R	6	V
	Power dissipation	P_D	120	mW
Output	V ₄₅ Allowed Range	V_o	0 to 16	V
	V ₆₅ Allowed Range	V_{CC}	3 to 16	V
	Output Current	I_o	50	mA
	Power dissipation	P_D	150	mW
Total power dissipation		P_{tot}	250	mW
Isolation voltage		V_{iso}	5000	V rms
Operating temperature		T_{opr}	-55~+100	°C
Storage temperature		T_{stg}	-55~+125	°C
Soldering temperature *2		T_{sol}	260	°C

Notes:

*1 AC for 1 minute, R.H.= 40 ~ 60% R.H. In this test, pins 1, 2 & 3 are shorted together, and pins 4, 5 & 6 are shorted together.

*2 For 10 seconds

Electro-Optical Characteristics (Ta=25°C unless specified otherwise)

Input

Parameter	Symbol	Min.	Typ.*	Max.	Unit	Condition
Forward Voltage	V_F	-	1.15	1.5	V	$I_F = 10\text{mA}$
Reverse Current	I_R	-	-	10	μA	$V_R = 5\text{V}$
Input capacitance	C_J	-	-	100	pF	$V=0, f=1\text{MHz}$

Output

Parameter	Symbol	Min.	Typ.*	Max.	Unit	Condition
Operation Voltage Range	V_{CC}	3	-	15	V	
Supply Current	$I_{CC(\text{off})}$	-	1.6	5	mA	$I_F=0\text{mA}, V_{CC}=5\text{V}$
Output Current, High	I_{OH}	-	-	100	μA	$I_F=0\text{mA}, V_{CC}=V_O=15\text{V}$
Isolation Resistance	R_{ISO}	10^{11}	-	-	Ω	$V_{I-O}=500\text{VDC}$

Transfer Characteristics

Parameter	Symbol	Min	Typ.	Max.	Unit	Condition
Supply Current	$I_{CC(\text{on})}$	-	1.6	5	mA	$I_F=10\text{mA}, V_{CC}=5\text{V}$
Output Voltage .low	V_{OL}	-	-	0.4	V	$V_{CC}=5\text{V}, I_F=I_{Fon}(\text{max.}), R_L=270\Omega$
Turn on Threshold Current ¹	H11L1	-	-	1.6	mA	$V_{CC}=5\text{V}, R_L=270\Omega$
	H11L2	-	-	10		
	H11L3	-	-	5		
Turn off Threshold Current	I_{Foff}	-	1	-	mA	$V_{CC}=5\text{V}, R_L=270\Omega$
Hysteresis Ratio	I_{Foff}/I_{Fon}	0.5	-	0.9		$V_{CC}=5\text{V}, R_L=270\Omega$
Turn on Time	t_{on}	-	-	4	μS	
Fall Time	t_f	-	0.1	-	μS	$V_{CC}=5\text{V}, I_F=I_{Fon}, R_L=270\Omega$
Turn off Time	t_{off}	-	-	4	μS	
Rise Time	t_r	-	0.1	-	μS	
Data Rate		-	1	-	MHz	

* Typical values at $T_a = 25^\circ\text{C}$

¹. Max. $I_{F(ON)}$ is the maximum current required to trigger the output. For examples, a 1.6mA maximum trigger current would require the LED to be driven at a current greater than 1.6mA to guarantee the device will turn on. A 10% guard band is recommended to account for degradation of the LED over its lifetime. The maximum allowable LED drive current is 60mA.

Typical Electro-Optical Characteristics Curves

Figure 1. Forward Current vs Forward Voltage

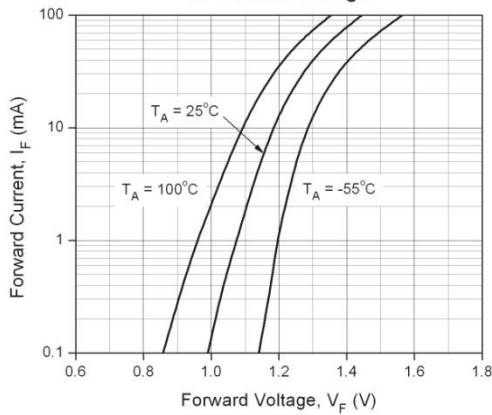

Figure 2. Transfer Characteristics

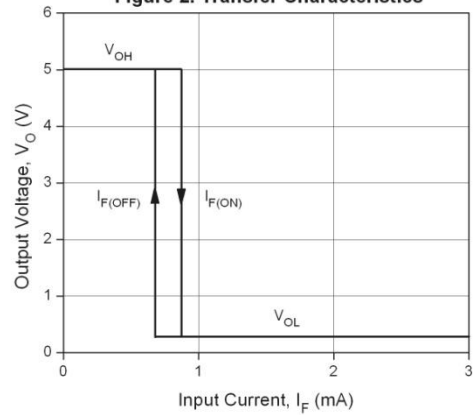

Figure 3. Turn On Threshold Current vs Supply Voltage

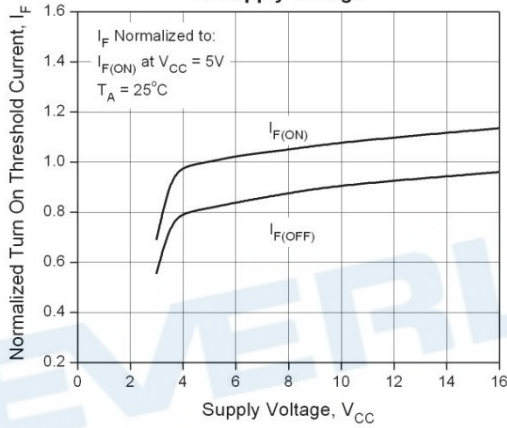

Figure 4. Turn On Threshold Current vs Ambient Temperature

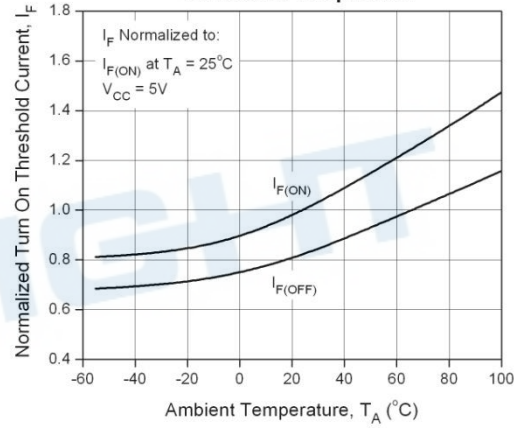

Figure 5. Low Level Output Voltage vs Load Current

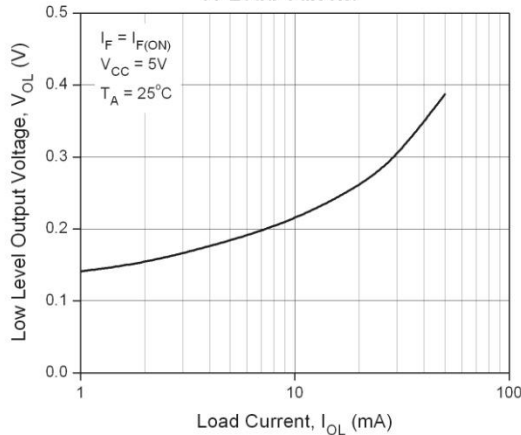
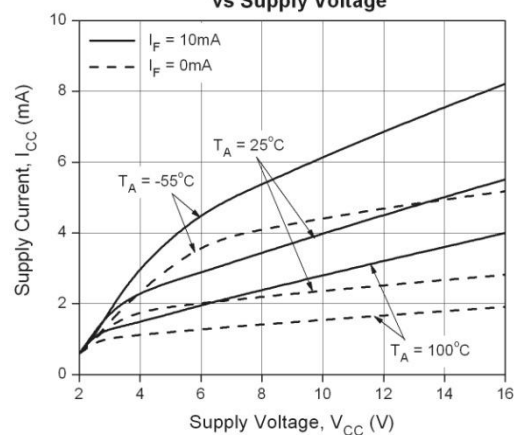

Figure 6. Supply Current vs Supply Voltage



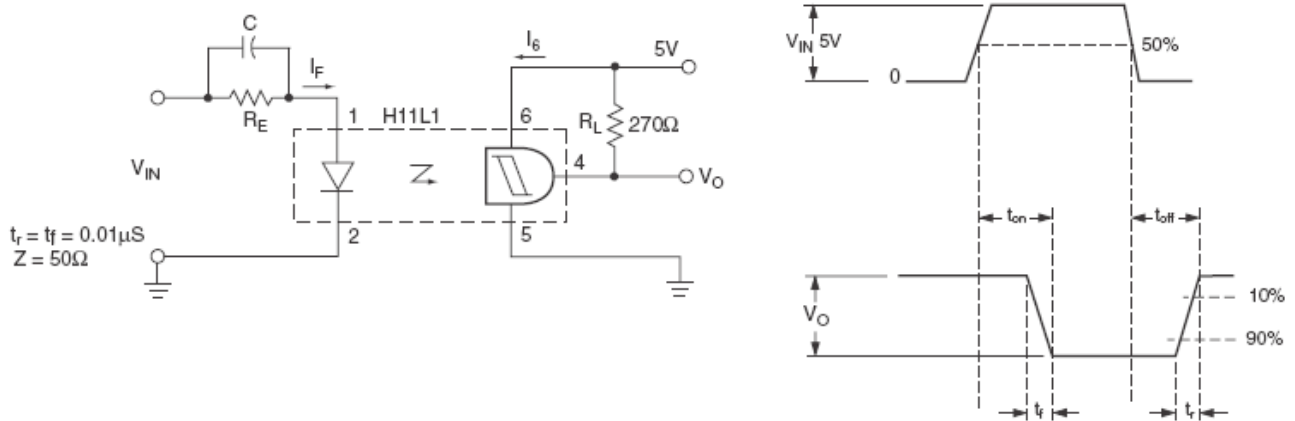

Figure 7. Switching Time Test Circuit & Waveforms

Order Information

Part Number

H11LXY(Z)-V

Note

- X = Part No. for 1, 2 or 3
- Y = Lead form option (S, S1, M or none)
- Z = Tape and reel option (TA, TB or none).
- V = VDE (optional)

Option	Description	Packing quantity
None	Standard DIP-6	65 units per tube
M	Wide lead bend (0.4 inch spacing)	65 units per tube
S + TA	Surface mount lead form + TA tape & reel option	1000 units per reel
S + TB	Surface mount lead form + TB tape & reel option	1000 units per reel
S1 + TA	Surface mount lead form (low profile) + TA tape & reel option	1000 units per reel
S1 + TB	Surface mount lead form (low profile) + TB tape & reel option	1000 units per reel

Package Dimension (Dimensions in mm)

Standard DIP Type

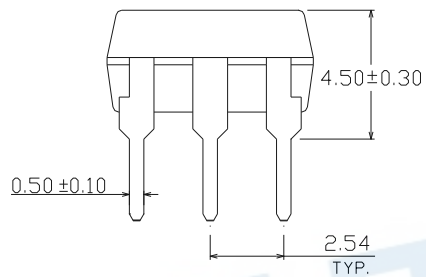
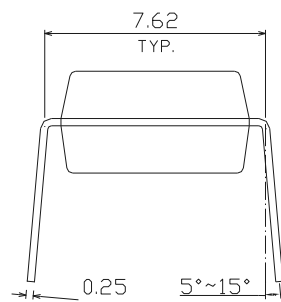
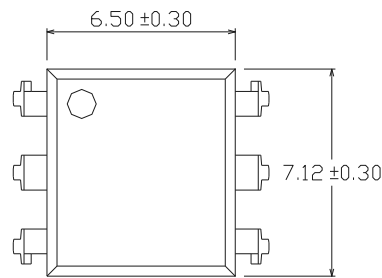

Option M Type

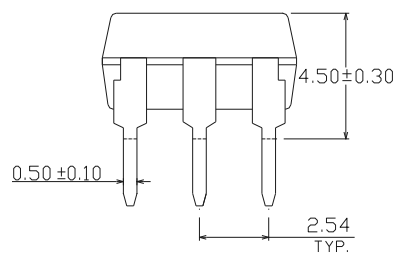
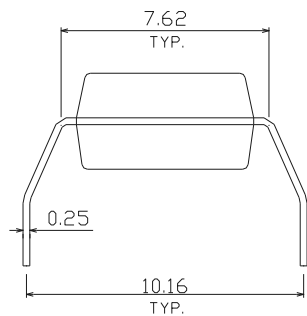
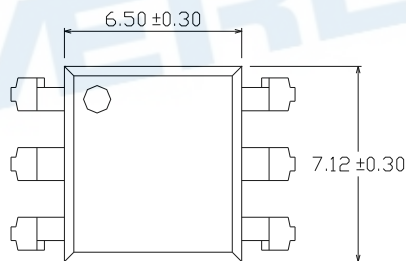

Option S Type

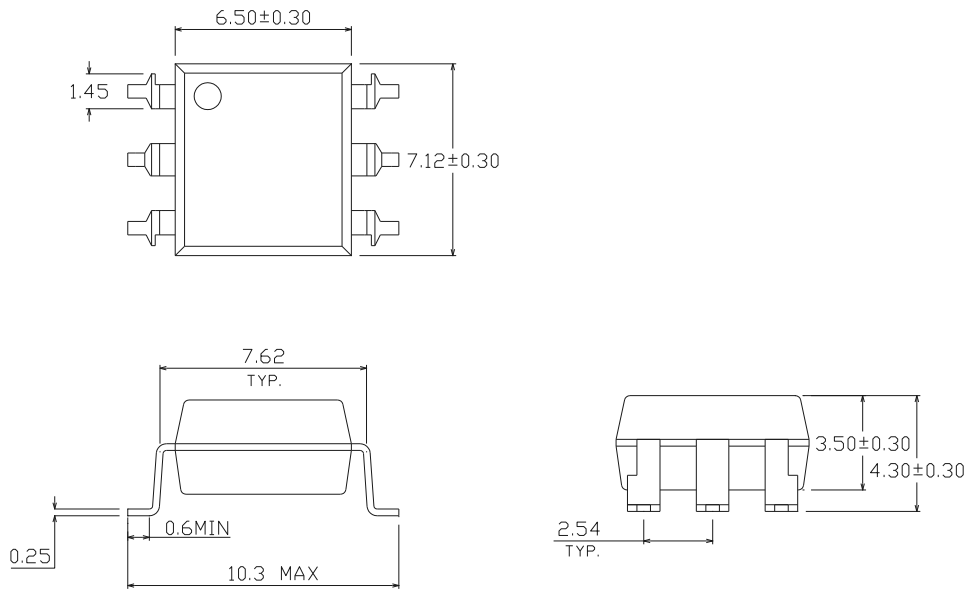

Option S1 Type

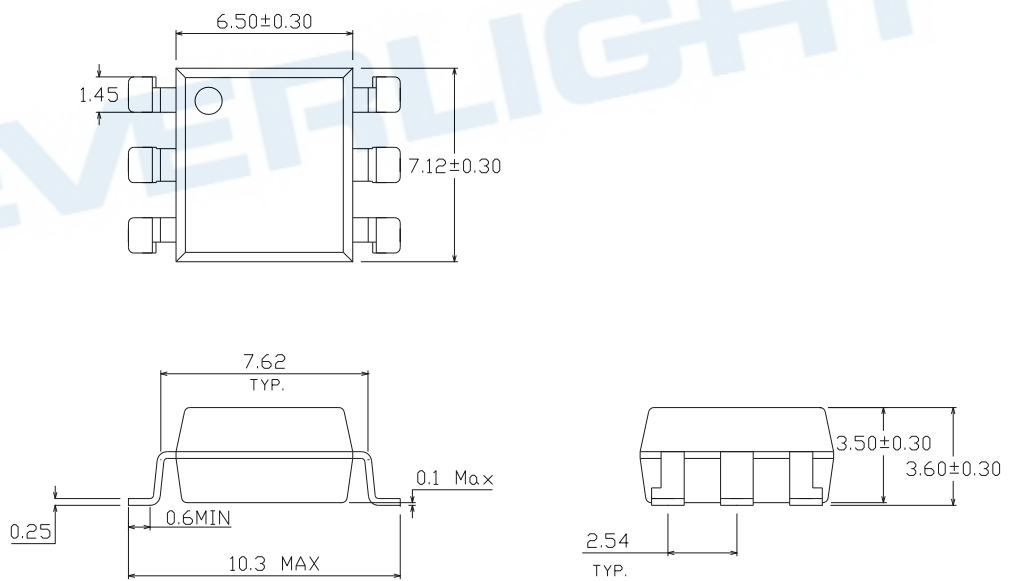

Recommended pad layout for surface mount leadform

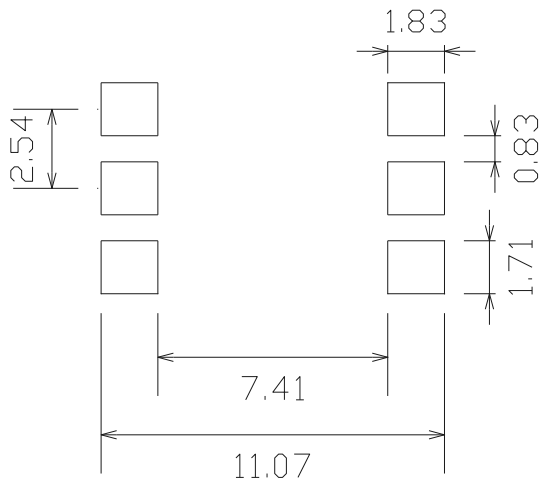

Notes

Suggested pad dimension is just for reference only.
Please modify the pad dimension based on individual need.

Device Marking

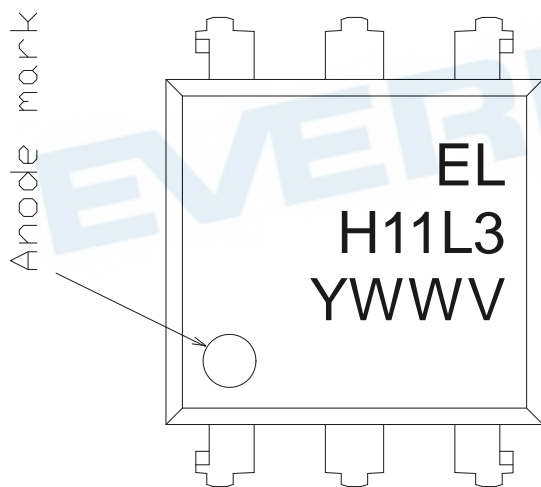

Notes

EL denotes Everlight
H11L3 denotes Device Number
Y denotes 1 digit Year code
WW denotes 2 digit Week code
V denotes VDE (optional)

Tape & Reel Packing Specifications

Option TA

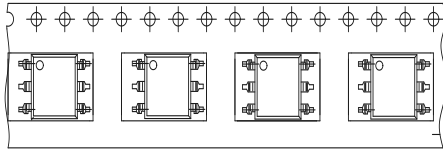

Direction of feed from reel

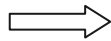

Option TB

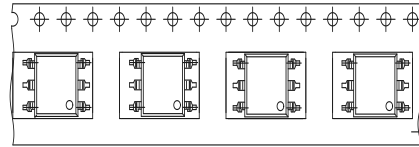

Direction of feed from reel

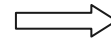

Tape dimensions

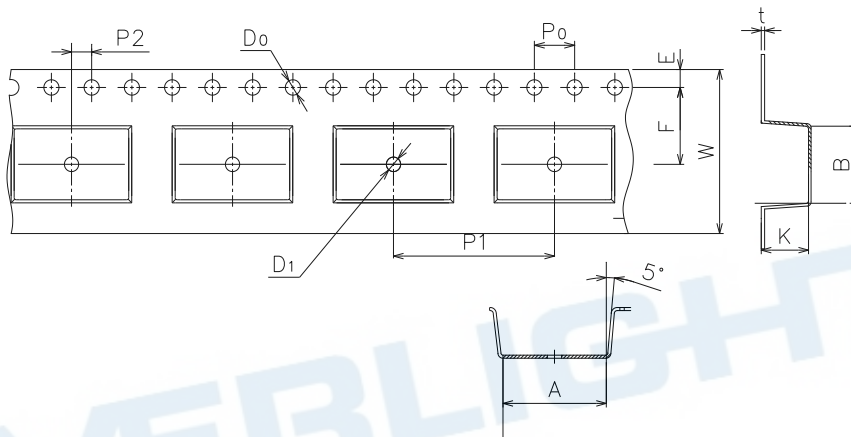

Dimension No.	A	B	Do	D1	E	F
Dimension(mm)	10.8±0.1	7.55±0.1	1.5±0.1	1.5+0.1/-0	1.75±0.1	7.5±0.1
Dimension No.	Po	P1	P2	t	W	K
Dimension(mm)	4.0±0.15	12±0.1	2.0±0.1	0.35±0.03	16.0±0.2	4.5±0.1

Precautions for Use

1. Soldering Condition

1.1 (A) Maximum Body Case Temperature Profile for evaluation of Reflow Profile

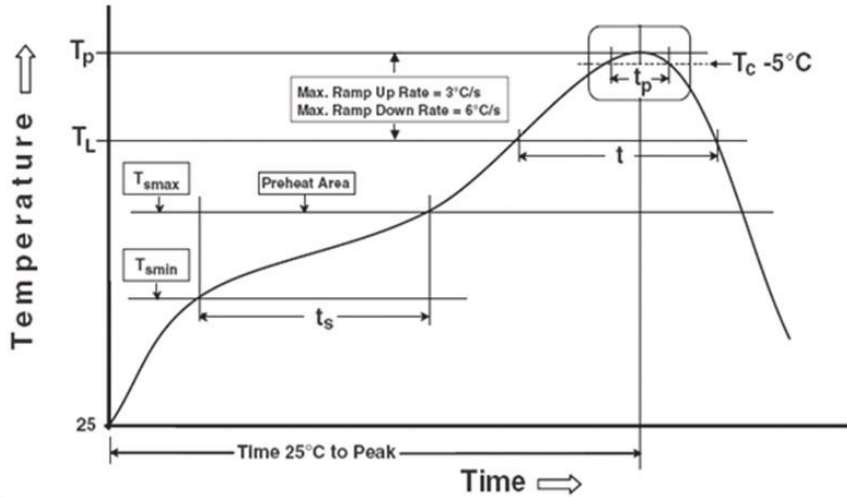

Note:

Reference: IPC/JEDEC J-STD-020D

Preheat

Temperature min (T_{smin})	150 °C
Temperature max (T_{smax})	200°C
Time (T_{smin} to T_{smax}) (t_s)	60-120 seconds
Average ramp-up rate (T_{smax} to T_p)	3 °C/second max

Other

Liquidus Temperature (T_L)	217 °C
Time above Liquidus Temperature (t_L)	60-100 sec
Peak Temperature (T_p)	260°C
Time within 5 °C of Actual Peak Temperature: $T_p - 5^\circ\text{C}$	30 s
Ramp- Down Rate from Peak Temperature	6°C /second max.
Time 25°C to peak temperature	8 minutes max.
Reflow times	3 times