

Star Magnetics™ 10/100BASE-T Transformer Modules with PoE* Option and 1:1 Turns Ratios

*Power over Ethernet

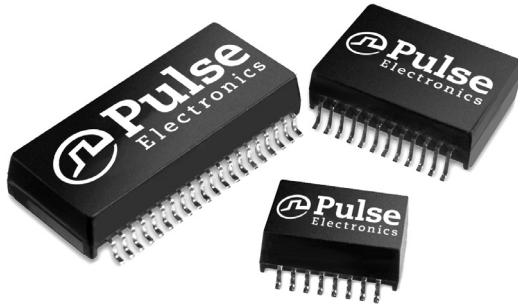

- RoHS peak reflow temperature rating 245°C
- Meets IEEE 802.3 specification
- Compact footprint

Electrical Specifications @ 25°C - Operating Temperature 0°C to 70°C

Part Number	PoE	Number of Ports	Insertion Loss (dB MAX)			Return Loss (Z out = 100 Ω ± 15%)			Crosstalk (adjacent channels dB MIN)			Hipot (Vrms MIN)
			0.1 MHz	1 MHz	100 MHz	30 MHz	60 MHz	80 MHz	30 MHz	60 MHz	100 MHz	
H0055NL ^{1, 6a, 7}	No	1	-2.5	—	-1.0	-16	-10	-10	-45	-40	-33	1500
H0056NL ^{2, 6a, 7}	No	1	—	-0.8	-0.9	-16	-10	-10	-45	-40	-33	1500
H1259NL ^{6a, 7}	No	4	-1.2	—	-1.4	-16	-10	-10	-45	-40	-33	1500
HX1259NL ^{3, 6a, 7}	No	4	-1.2	—	-1.4	-16	-10	-10	-45	-40	-33	1500
H1260NL ^{6a, 7}	No	1	-1.1	—	-1.1	-16	-10	-10	-35	-30	-30	1500
HX1260NL ^{3, 6a, 7}	No	1	-1.1	—	-1.1	-16	-10	-10	-35	-30	-30	1500
H1278NL ^{6a, 7}	No	1	-1.1	—	-1.0	-16	-10	-10	-45	-40	-33	1500
H1305NL ^{6a, 7}	No	2	-1.2	—	-1.4	-16	-10	-10	-45	-40	-33	1500
HX1305NL ^{3, 6a, 7}	No	2	-1.2	—	-1.4	-16	-10	-10	-45	-40	-33	1500
H2260NL ^{6a, 7}	Yes ^d	1	-1.1	—	-1.1	-16	-10	-10	-35	-30	-30	1500
HX2260NL ^{3, 6a, 7}	Yes ^d	1	-1.1	—	-1.1	-16	-10	-10	-35	-30	-30	1500
H2305NL ^{6a, 7}	Yes ^d	2	-1.2	—	-1.4	-16	-10	-10	-45	-40	-33	1500
HX2305NL ^{3, 6a, 7}	Yes ^d	2	-1.2	—	-1.4	-16	-10	-10	-45	-40	-33	1500

Notes:

1. H0055NL is designed to meet 200 μH nom.
2. H0056NL is designed to meet 300 μH nom.
3. Parts offer extended operating temperature of -40 to +85°C
4. These parts are compliant to IEEE802.3af, Power over Ethernet (PoE) standard.
5. When ordering Tape & Reel packaging, add a "T" suffix to the end of the part number, e.g. H0056NLT
6. MSL = Moisture Sensivity Level: a=1, b=2, c=3, d=4, e=5
7. Not for sale in U.S.

USA 858 674 8100

Germany 49 7032 7806 0

Singapore 65 6287 8998

Shanghai 86 21 62787060

China 86 755 33966678

Taiwan 886 3 4356768

Star Magnetics™ 10/100BASE-T Transformer Modules with PoE* Option and 1:1 Turns Ratios

*Power over Ethernet



Mechanicals

H0055NL

SUGGESTED LAND PATTERN

Weight0.35 grams
Tape & Reel1000/reel
Tube40/tube

H0056NL

SUGGESTED LAND PATTERN

Weight0.30 grams
Tape & Reel2000/reel
Tube40/tube

Dimensions: $\frac{\text{Inches}}{\text{mm}}$ Unless otherwise specified, all tolerances are $\pm \frac{.010}{0,25}$

H1259NL, HX1259NL

SUGGESTED PAD LAYOUT

Weight3.4 grams
Tape & Reel250/reel
Tube15/tube

H1260NL, HX1260NL, H2260NL, HX2260NL

SUGGESTED PAD LAYOUT

Weight0.9 grams
Tape & Reel600/reel
Tube40/tube

Dimensions: $\frac{\text{Inches}}{\text{mm}}$ Unless otherwise specified, all tolerances are $\pm \frac{.010}{0,25}$

Star Magnetics™ 10/100BASE-T Transformer Modules with PoE* Option and 1:1 Turns Ratios

*Power over Ethernet



Mechanicals (continued)

H1278NL

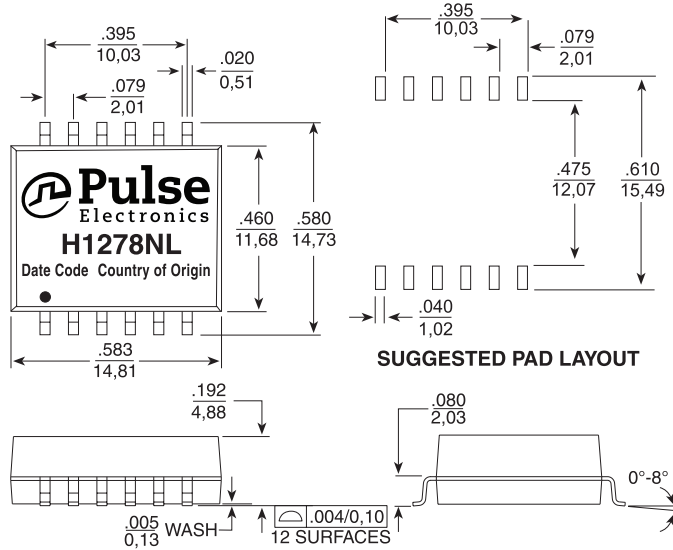

Weight0.9 grams
Tape & Reel350/reel
Tube35/tube

Dimensions: $\frac{\text{Inches}}{\text{mm}}$ Unless otherwise specified, all tolerances are $\pm \frac{.010}{0,25}$

H1305NL, HX1305NL, H2305NL, HX2305NL

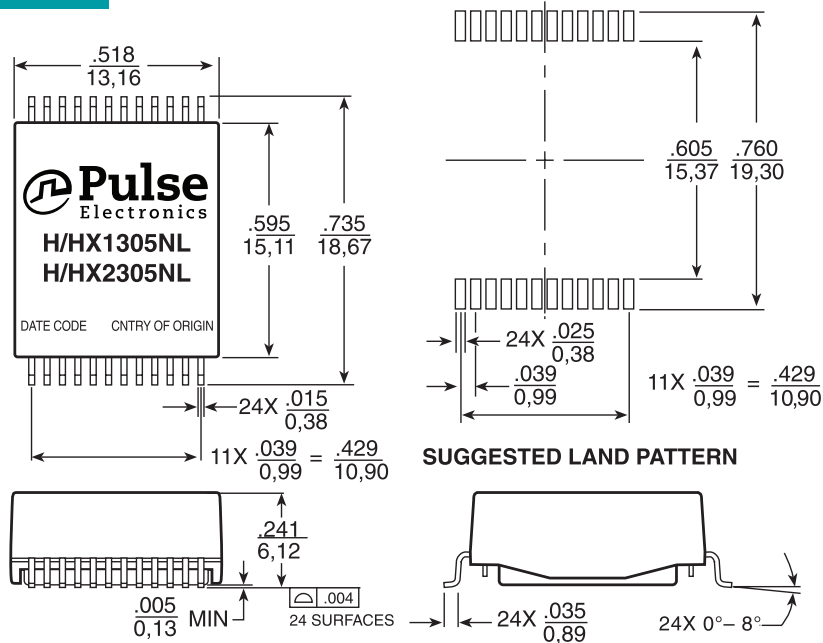

Weight2.7 grams
Tape & Reel350/reel
Tube35/tube

Dimensions: $\frac{\text{Inches}}{\text{mm}}$ Unless otherwise specified, all tolerances are $\pm \frac{.010}{0,25}$

Star Magnetics™ 10/100BASE-T Transformer Modules with PoE* Option and 1:1 Turns Ratios

*Power over Ethernet



Schematics

H0055NL

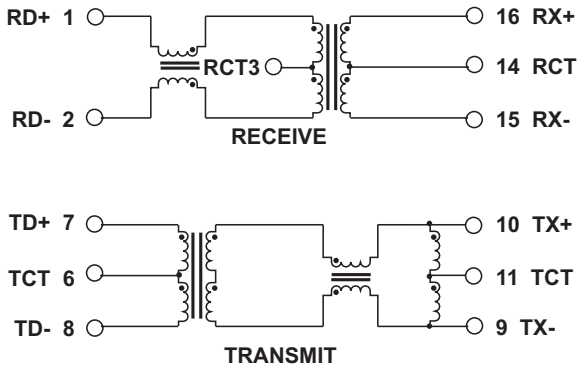

H0056NL

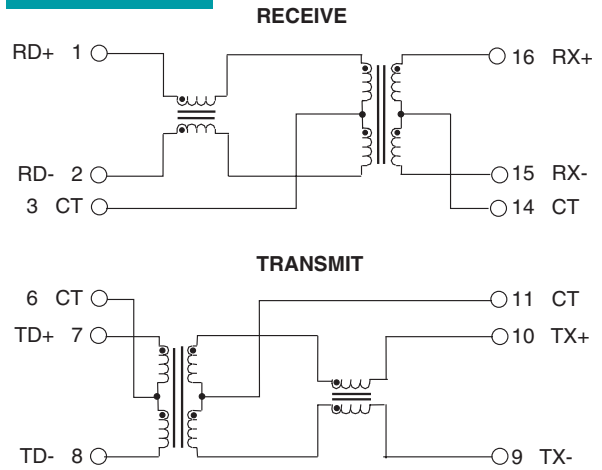

H1260NL, HX1260NL

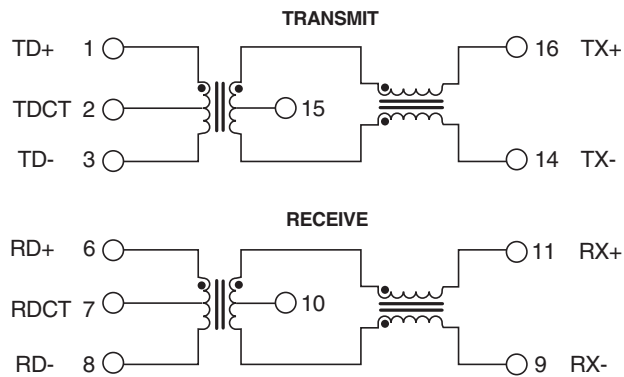

H1278NL

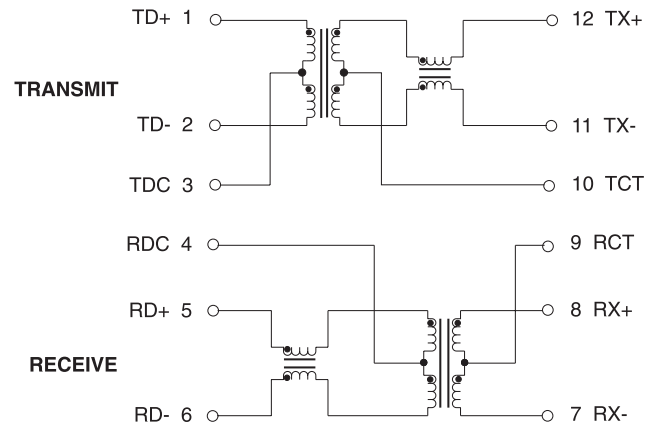

H2260NL, HX2260NL

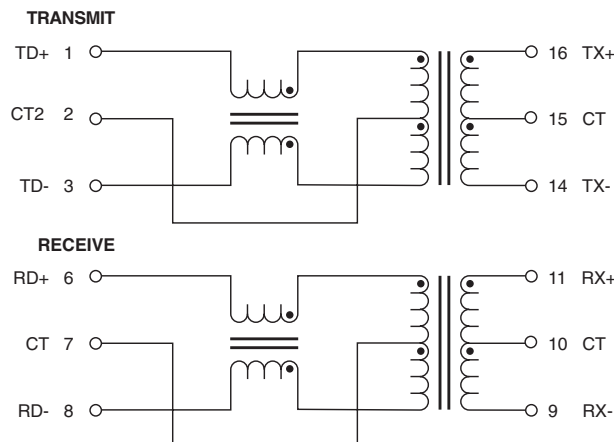

Star Magnetics™ 10/100BASE-T Transformer Modules with PoE* Option and 1:1 Turns Ratios

*Power over Ethernet



Schematics (continued)

H1305NL, HX1305NL

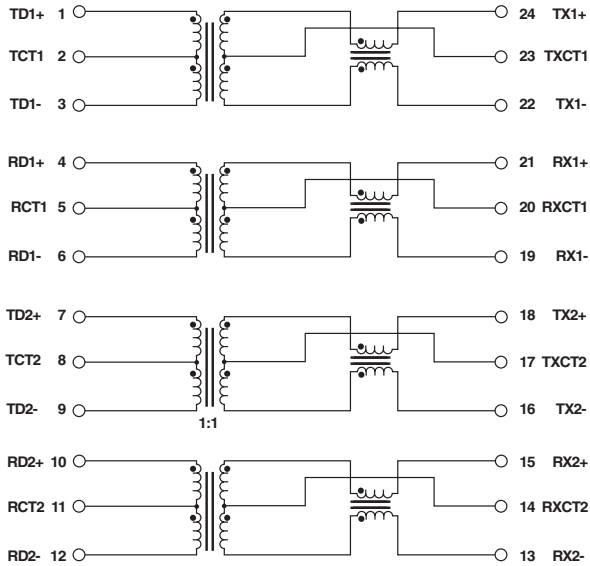

H1278NL

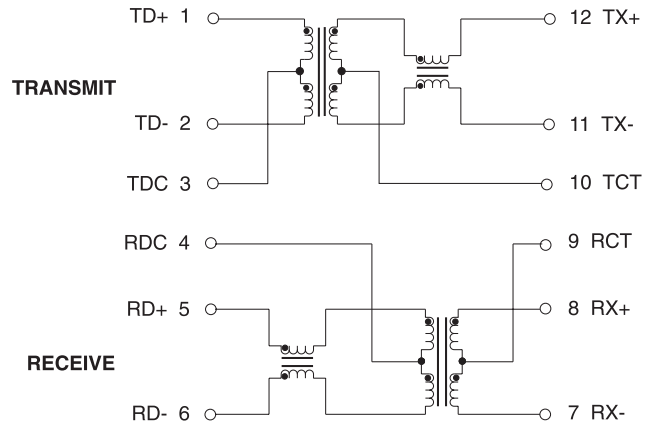

H2305NL, HX2305NL

