

Jun.1.2021 Copyright 2021 HIROSE ELECTRIC CO., LTD. All Rights Reserved.
 In case of consideration for using Automotive equipment / device which demand high reliability, kindly contact our sales window correspondents.

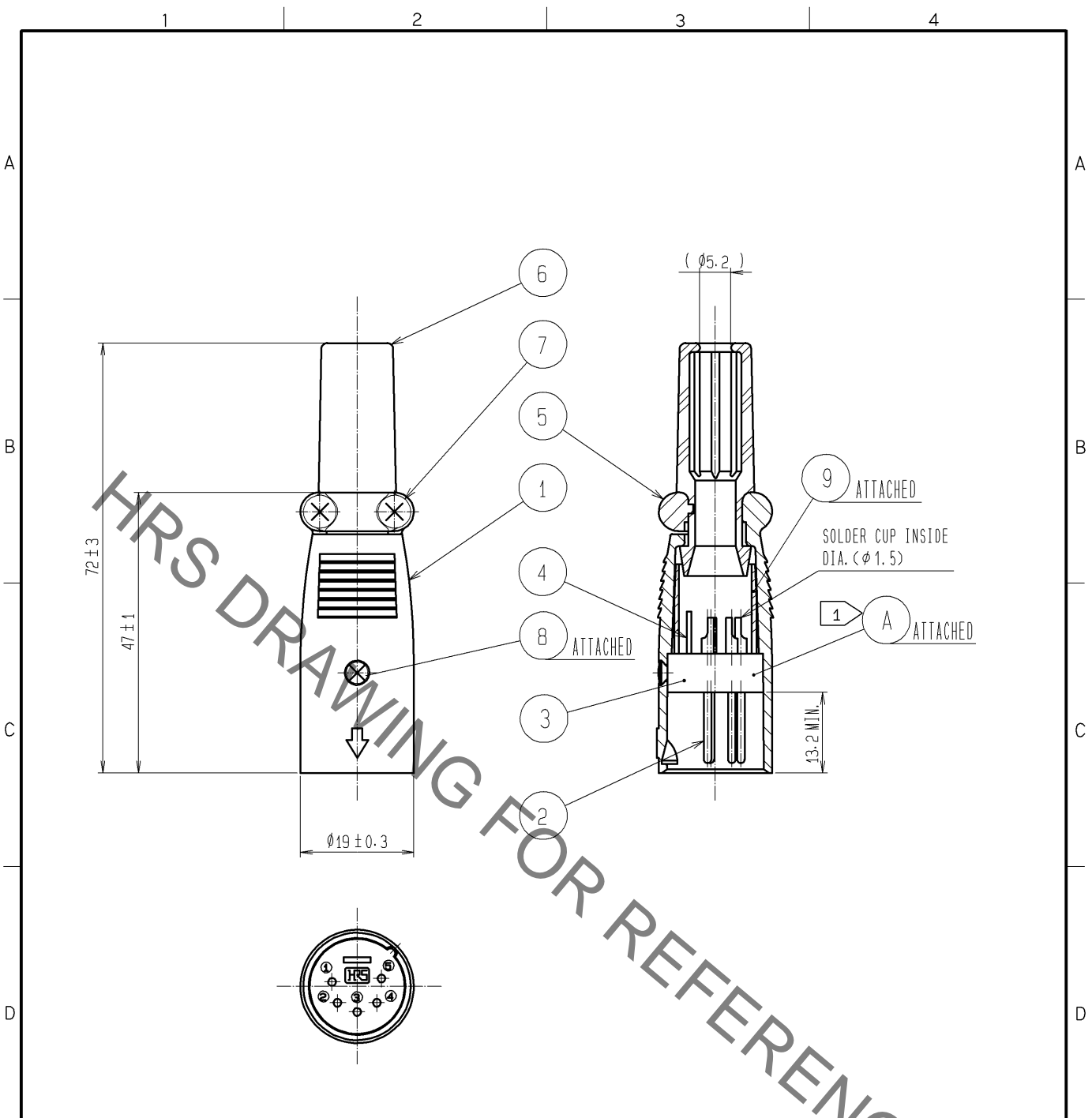

NOTES 1 A SPECIFIES A BLOCK WHICH REF. NO. 2 TO NO. 4 ARE INCORPORATED.
2 THE CABLE PULL AND TWISTING STRENGTH AND OTHER CHARACTERISTICS MAY DIFFER, DEPENDING ON THE CABLE STRUCTURE. PLEASE CONFIRM BEFORE THE USE.

NO.	MATERIAL	FINISH , REMARKS	NO.	MATERIAL	FINISH , REMARKS
5	ZINC ALLOY	MATTE FINISH NICKEL PLATED			
4	BRASS	SILVER PLATING	9	PVC	(BLACK)
3	POLYAMIDE	(GRAY)	8	STEEL	NICKEL PLATING M2.6X0.45X8
2	BRASS	SILVER PLATING 2µm min.	7	BRASS	NICKEL PLATING M3X0.5X8
1	ZINC ALLOY	MATTE FINISH NICKEL PLATED	6	CHLOROPRENE RUBBER	(BLACK)

UNITS mm		SCALE 1 : 1	COUNT 	DESCRIPTION OF REVISIONS	DESIGNED	CHECKED	DATE
-------------	--	----------------	-----------	--------------------------	----------	---------	------

	APPROVED : SU. OBARA	10.03.25	DRAWING NO.	EDC4-024100-76
	CHECKED : HY. KISHI	10.03.25	PART NO.	HA216J-5P(76)
	DESIGNED : HK. NAMA I	10.03.25	CODE NO.	CL104-0706-2-76
	DRAWN : HK. NAMA I	10.03.25		1/1