

Installation Instructions for the Honeywell Zephyr™ Digital Airflow Sensors HAF Series—High Accuracy ±50 SCCM to ±750 SCCM

50045178
Issue E

GENERAL INFORMATION

CAUTION

IMPROPER USE

Do not use to sense liquid flow.

Failure to comply with these instructions may result in product damage.

CAUTION

IMPROPER CLEANING

- Avoid cleaning the sensor; however, if it must be cleaned use isopropyl alcohol and dry the device thoroughly before use. Cap the ports or connect housing to the ports before cleaning the sensor with alcohol. Using alcohol may remove the text on the sensor label; however, the label ID is hard coded inside the sensor.
- Do not use III Tri-chloroethane, methylene chloride, methyl pyrrolidone, or any oxidizing type acid such as formic acid.
- Do not use ultrasonic cleaning.

Failure to comply with these instructions may result in product damage.

CAUTION

LARGE PARTICULATE DAMAGE

Use a 5-micron filter upstream of the sensor to keep media flow through the sensor free of condensing moisture and particulates. Large, high-velocity particles or conductive particles may damage the sensing element.

Failure to comply with these instructions may result in product damage.

Table 1. Absolute Maximum Ratings

Characteristic	Parameter
Supply voltage	-0.3 Vdc to 6.0 Vdc
Voltage on I/O output pin	-0.3 Vdc to Vsupply
Storage temperature range	-40 °C to 125 °C [-40 °F to 257 °F]
Maximum flow change	5.0 SLPM/s
Maximum common mode pressure	25 psi at 25 °C [77 °F]
Maximum flow	10 SLPM

NOTICE

Absolute maximum ratings are the extreme limits that the device will withstand without damage to the device. However, the electrical and mechanical characteristics are not guaranteed as the maximum limits (above recommended operating conditions) are approached, nor will the device necessary operate at absolute maximum ratings.

Table 2. Operating Specifications

Characteristic	Parameter	Notes	
Supply voltage:	3.3 Vdc 5.0 Vdc	3.3 Vdc ±10% 5.0 Vdc ±10%	—
Power:	3.3 Vdc 5.0 Vdc	40 mW max. 65 mW max.	1
Compensated temperature range	0 °C to 50 °C [32 °F to 122 °F]		2
Operating temperature range	-20 °C to 70 °C [-4 °F to 158 °F]		—
Warm-up time	30 ms		3
Calibration media	gaseous nitrogen		4
Bus standards	I ² C fast mode (up to 400 kHz)		5
Reverse polarity protection	no		—

Notes:

1. Maximum power: Is measured under the conditions of the highest supply voltage, Vsupply + 10%, 70 °C, full scale flow and with the minimum load specified for that supply voltage.
2. Custom and extended compensated temperature ranges are possible. Contact Honeywell for details.
3. Warm-up time: The time to the first valid flow measurement after power is applied.
4. Default calibration media is dry nitrogen gas. Please contact Honeywell for other calibration options.
5. Refer to the Technical Note "I²C Communications with Honeywell Digital Airflow Sensors" for I²C protocol information.

Table 3. Environmental Characteristics

Characteristic	Parameter
Humidity	0% to 95% RH, non-condensing
Shock	100 g, 11 ms
Vibration	15 g at 20 Hz to 2000 Hz
ESD	Class 3B per MIL-STD 883G

Table 4. Wetted Materials

Characteristic	Parameter
Covers	high temperature polymer
Substrate	PCB
Adhesives	epoxy
Electronic components	silicon, gold
Compliance	RoHS, WEEE

Table 5. Recommended Mounting and Implementation

Characteristic	Parameter
Mounting screw: size torque	5-40 0.68 N m [6 in lb]
Silicone tubing for long port style	70 durometer; 0.125 inch inside diameter, 0.250 inch outside diameter
O-ring: short port style long port style	AS568A, Size 7, Silicone, Shore A 70 AS568A, Size 10, Silicone, Shore A 70
Filter	5-micron filter upstream of sensor

Honeywell Zephyr™ Digital Airflow Sensors

HAF Series—High Accuracy

±50 SCCM to ±750 SCCM

Issue E
50045178

Figure 1. Wave Solder Profile

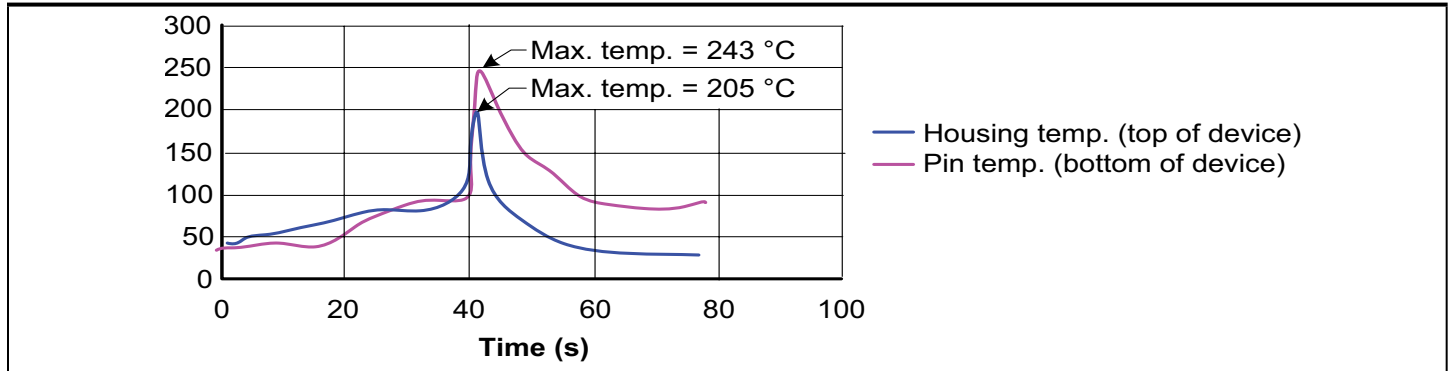

Digital Interface

For additional details on the use of Zephyr with digital output see the Technical Note “I²C Communications with Honeywell Digital Airflow Sensors”.

The sensor uses the I²C standard for digital communication with a slave address specified in the Nomenclature and Order Guide in Figure 2. Following sensor power-up, each of the first two read sequences shown in Figure 9 will respond with 2 bytes of the unique 4-byte Serial Number. The first read after power-up will respond with the two most significant bytes of the Serial Number, while the second read will respond with the two least significant bytes of the Serial Number. For reliable performance, allow sensor to be powered for the sensor start-up time before performing the first read, then allow a 10 ms command response time before performing the second read.

Figure 2. Sensor I²C Read and Write Sequences

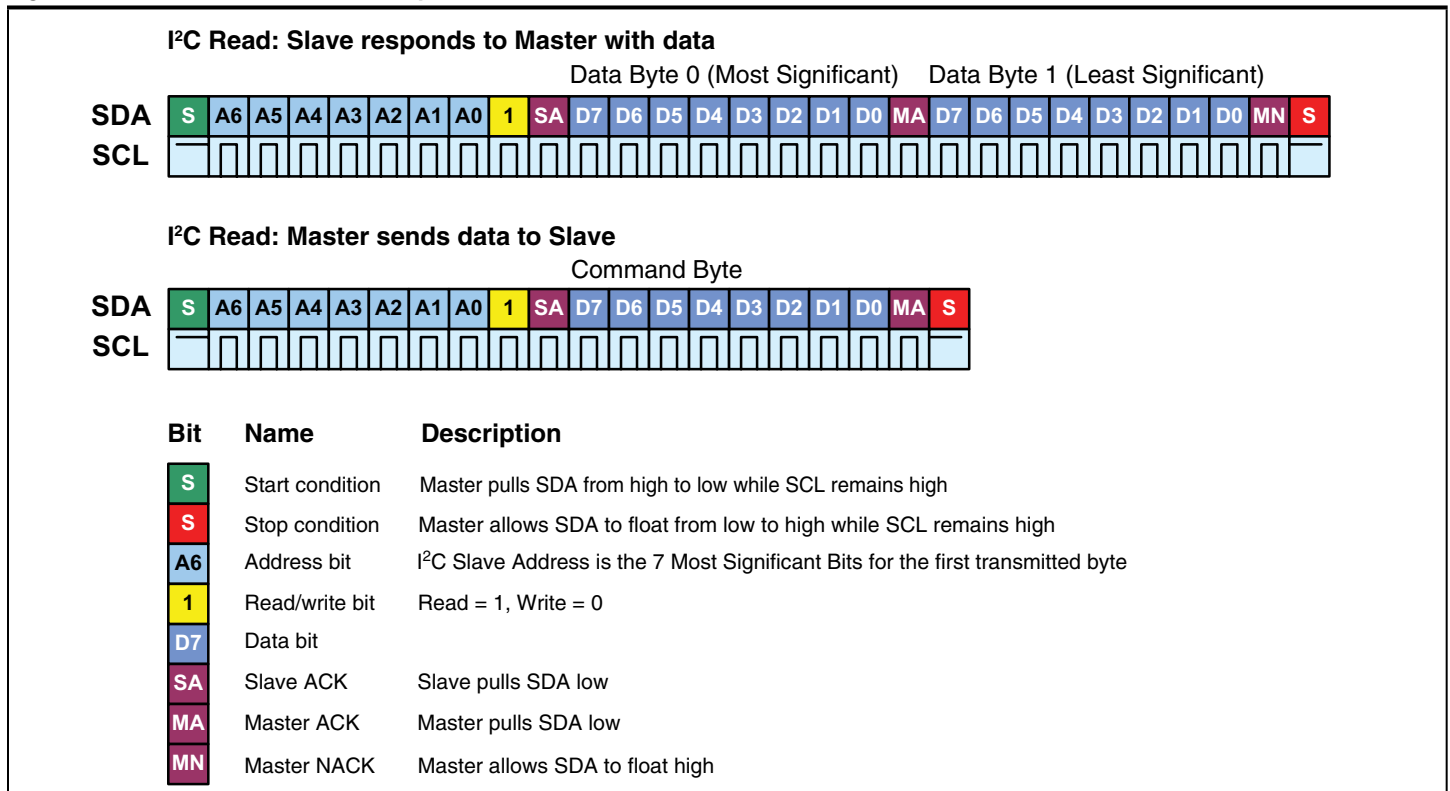

After the power-up read sequence described above, the sensor will respond to each I²C read request with a 16-bit (2 byte) digital flow reading. Read requests taken faster than the Response Time (1 ms) are not guaranteed to return fresh data. The first two bits of each flow reading will be ‘00’.

The maximum sink current on SCL or SDA is 2 mA. Therefore, if the pull-up resistors are biased by V_{DD}, and if V_{DD} reaches the maximum supply voltage of 6 V, then the pull-up resistors for SCL and SDA must be greater than 3.0 kΩ to limit the sink current to 2 mA. The typical value for SCL and SDA pull-up resistors is 4.7 kΩ (this value depends on the bus capacitance and the bus speed).

Honeywell Zephyr™ Digital Airflow Sensors

HAF Series—High Accuracy

±50 SCCM to ±750 SCCM

Issue E
50045178

Figure 3. Mounting Dimensions (For reference only: mm [in.])

LF: Long port, fastener mount

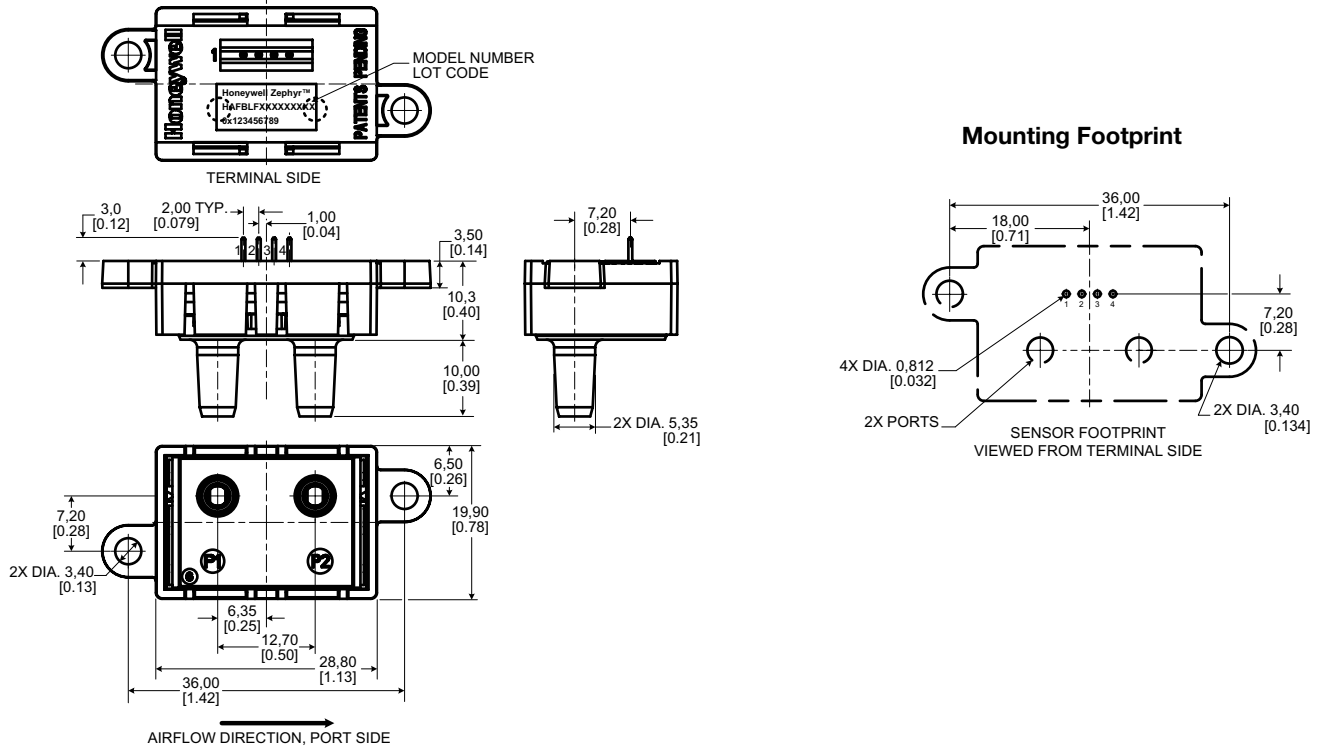

SF: Short port, fastener mount

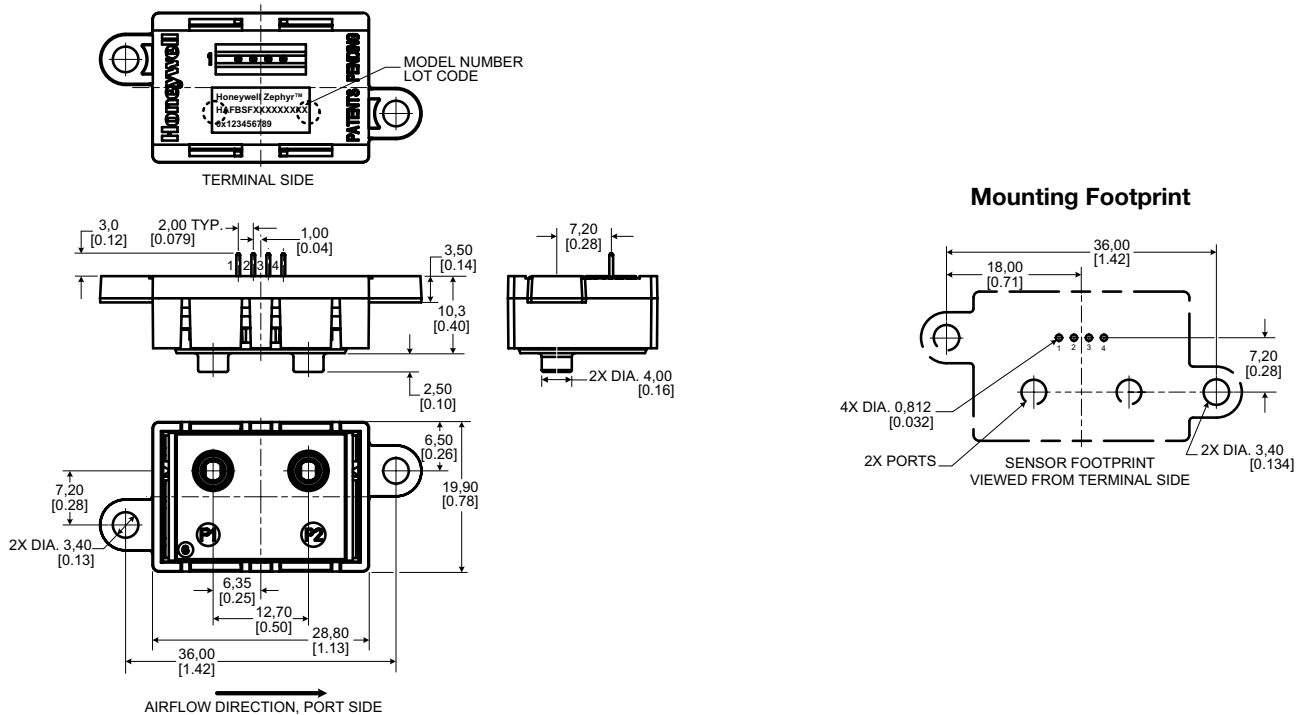

Honeywell Zephyr™ Digital Airflow Sensors

HAF Series—High Accuracy

±50 SCCM to ±750 SCCM

Issue E
50045178

Figure 3. Mounting Dimensions (continued)

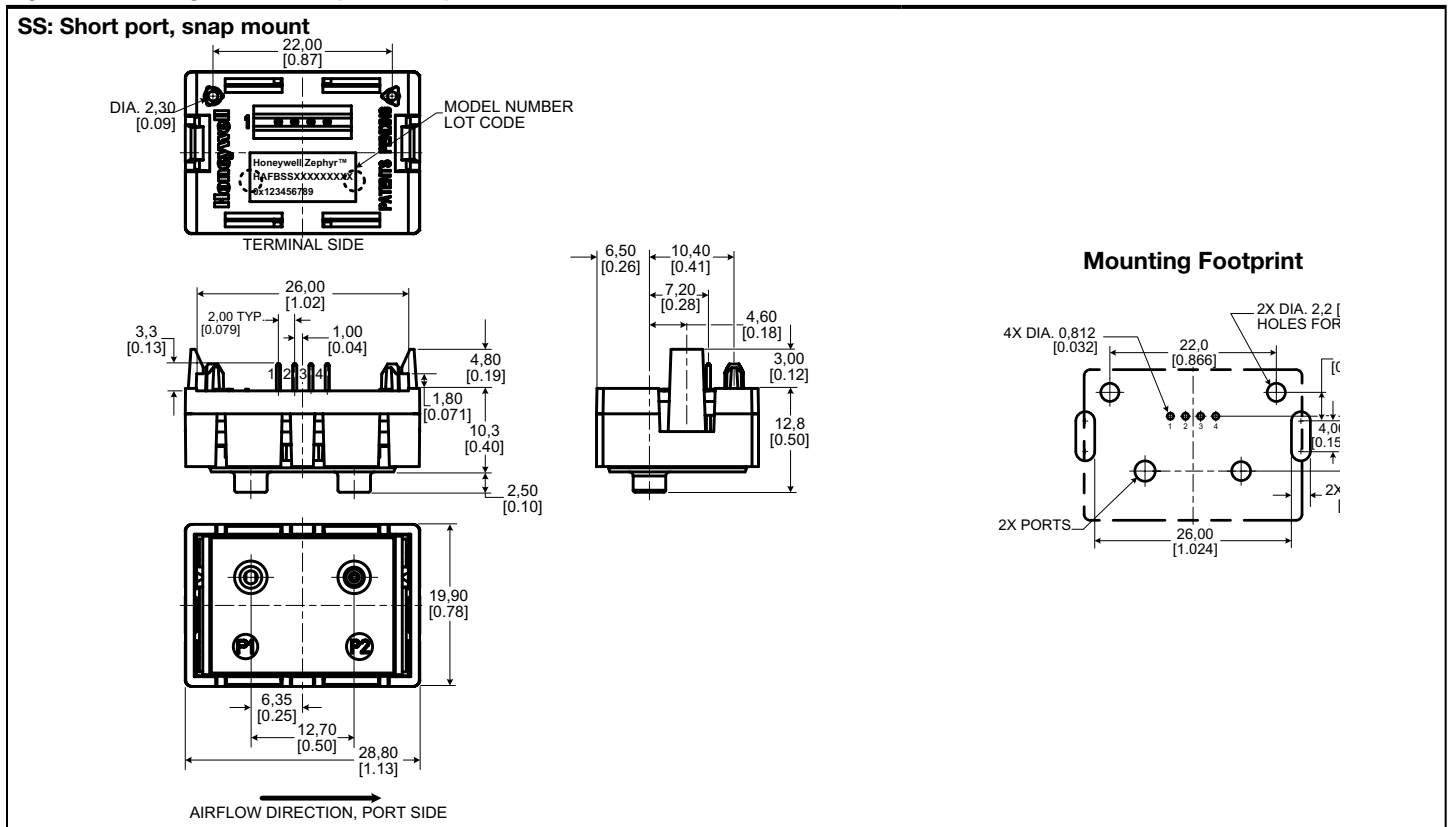
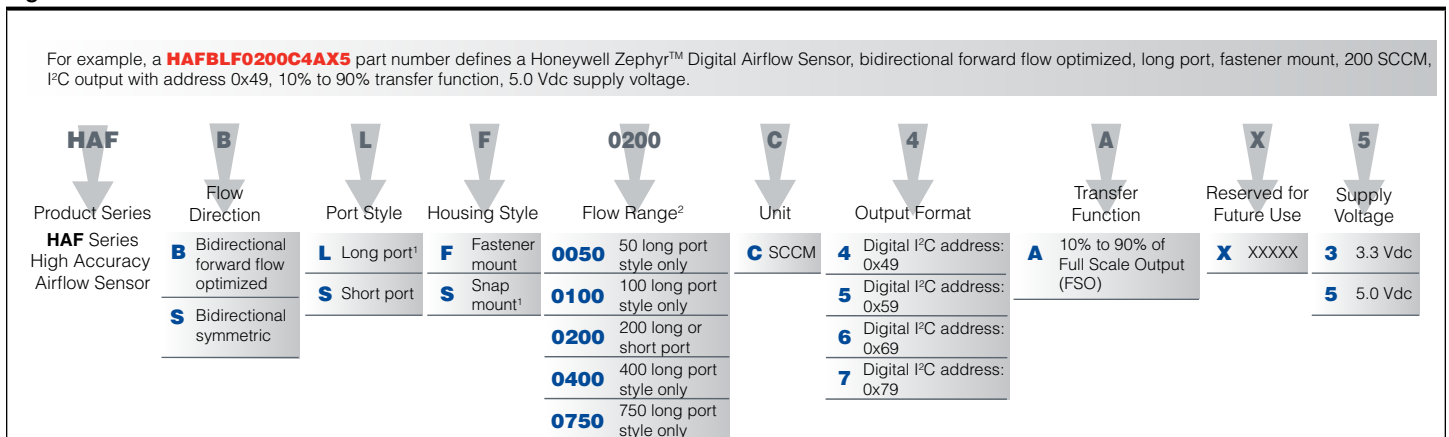

Table 5. Pinout

Pin 1	Pin 2	Pin 3	Pin 4
SCL	Vsupply	ground	SDA

Figure 4. Nomenclature and Order Guide



¹The Long Port Port Style with the Snap Mount Housing Style is not a valid configuration.

²The 200 SCCM Flow Range is available in the Long and Short Port Styles.

Apart from the general configuration required, other customer-specific requirements are also possible. Please contact Honeywell.