

HBS502-HF Thru. HBS510-HF

Reverse Voltage: 200 to 1000 V

Forward Current: 5.0 A

RoHS Device
Halogen Free

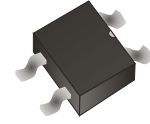

Features

- Surface mount bridge, small package.
- Ideal for printed circuit boards.
- Glass passivated chip junction.
- High forward current capability up to 5A.
- High surge current capability.
- Low profile package.
- Low forward voltage drop.
- Plastic package has underwrites laboratory flammability classification 94V-0.

Mechanical data

- Case: HBS, molded plastic.
- Epoxy: UL-94V-0 flammability rating.
- Terminals: Matte tin plated leads, solderable per J-STD-002 and JESD22-B102.
- Polarity: As marked on body.

Circuit Diagram

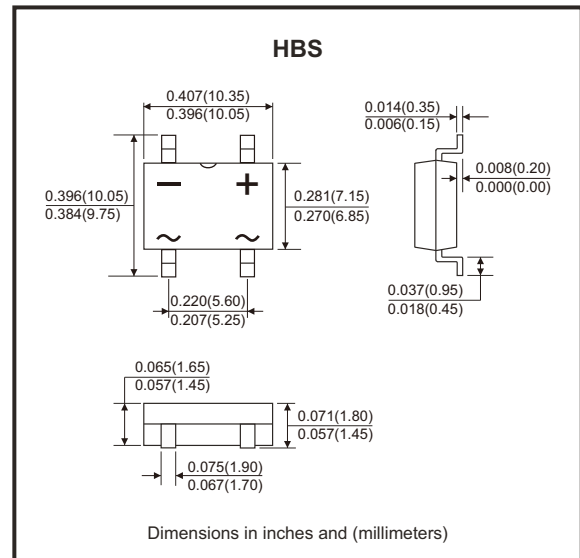
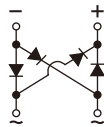

Maximum Ratings and Electrical Characteristics

(at $T_A=25^\circ\text{C}$, unless otherwise specified)
Single phase, half wave, 60Hz, resistive or inductive load. For capacitive load, derate current by 20%.

Parameter	Symbol	HBS 502-HF	HBS 504-HF	HBS 506-HF	HBS 508-HF	HBS 510-HF	Unit
Max. repetitive peak reverse voltage	V_{RRM}	200	400	600	800	1000	V
Max. RMS voltage	V_{RMS}	140	280	420	560	700	V
Max. DC blocking voltage	V_{DC}	200	400	600	800	1000	V
Max. average forward rectified output current at $T_A=25^\circ\text{C}$	$I_{F(AV)}$	5					A
Non-repetitive peak forward surge current 8.3ms single sine-wave superimposed on rated load (JEDEC Method)	I_{FSM}	130					A
Rating for fusing ($t < 8.3\text{ms}$)	I^2t	93					A^2sec
Instantaneous forward voltage drop per diode	@ $I_F=1\text{A}$	0.83 Typ.			0.88 Max.		V
	@ $I_F=2.5\text{A}$	0.88 Typ.			0.93 Max.		
	@ $I_F=5\text{A}$	0.92 Typ.			0.97 Max.		
Reverse current at rated DC blocking voltage	$T_A=25^\circ$	0.15 Typ.			5 Max.		μA
	$T_A=125^\circ$	20 Typ.			100 Max.		
Typical capacitance (Note 1)	C_J	38					pF
Typical thermal resistance	$R_{\theta JA}$	69					$^\circ\text{C/W}$
	$R_{\theta JC}$	12					
	$R_{\theta JL}$	12					
Operating junction and storage temperature range	T_J, T_{STG}	-55 to +150					$^\circ\text{C}$

Notes: 1. Measured at 1MHz and applied reverse voltage of 5V DC.

Company reserves the right to improve product design, functions and reliability without notice.

REV:A

Rating and Characteristics Curves (HBS502-HF Thru. HBS510-HF)

Fig.1 - Derating Curve Output Rectified Current

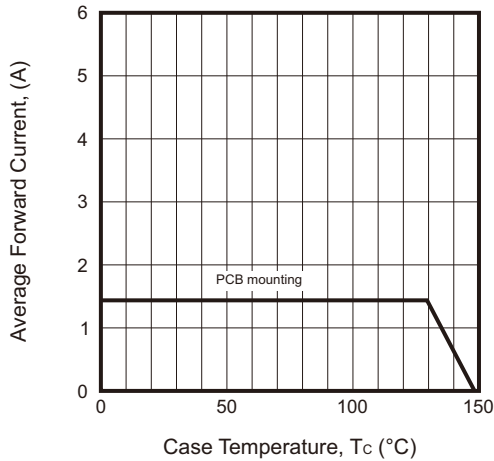

Fig.2 - Typ. Forward Characteristics per Diode

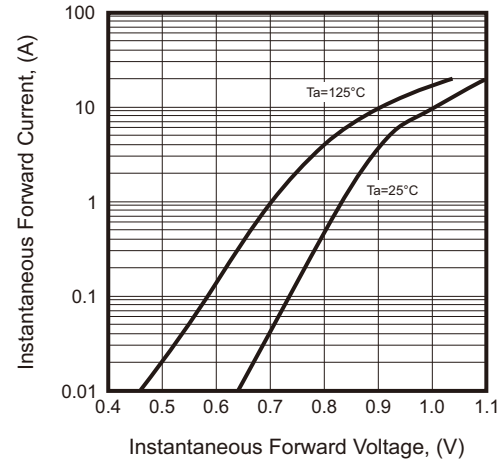

Fig.3 - Max. Non-Repetitive Peak Forward Surge Current per Diode

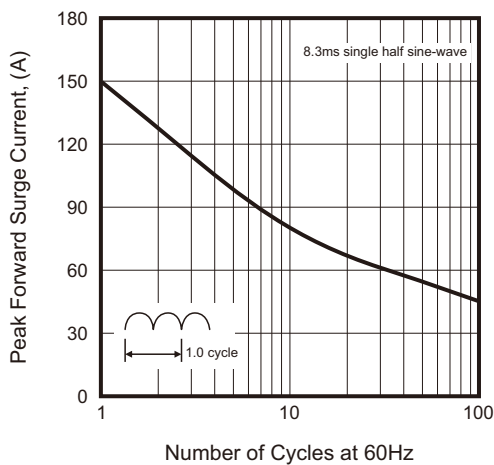

Fig.4 - Typ. Reverse Characteristics per Diode

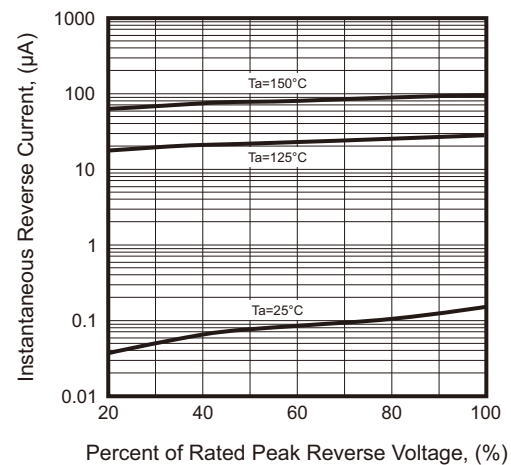
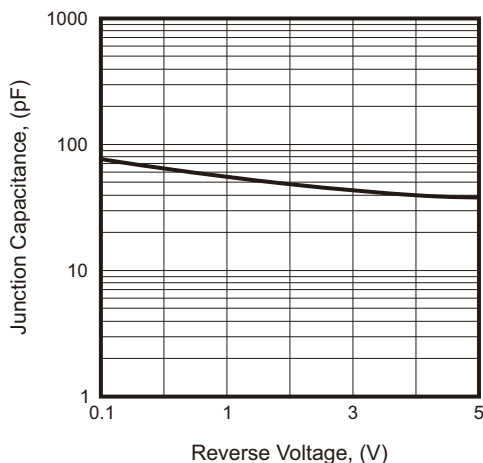

Fig.5 - Typ. Junction Capacitance per Diode



Company reserves the right to improve product design, functions and reliability without notice.

REV:A

Reel Taping Specification

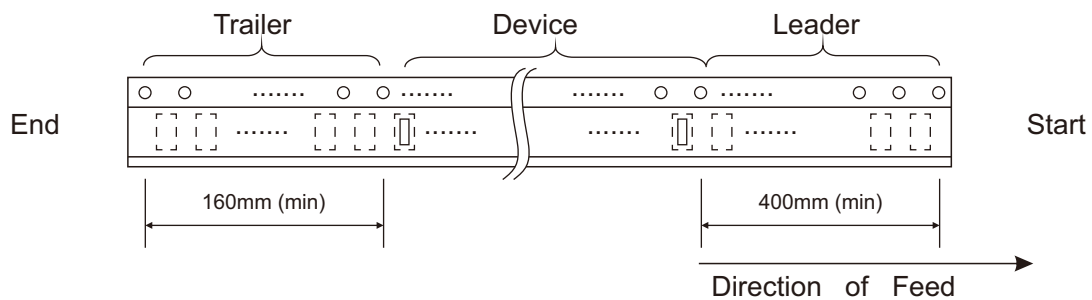
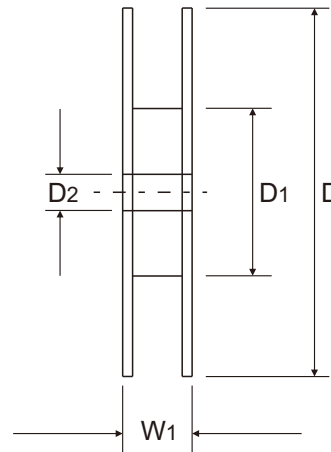
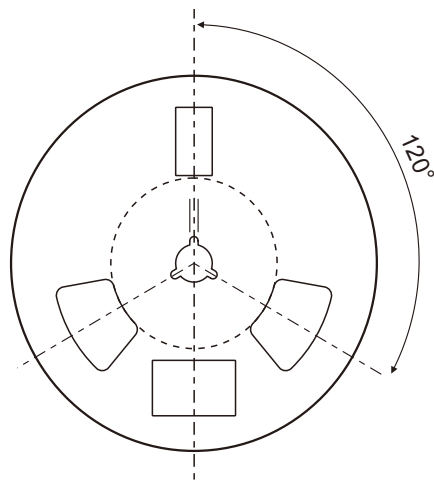
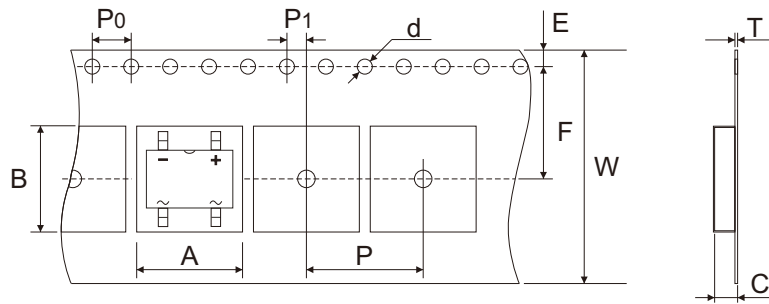

HBS	SYMBOL	A	B	C	d	D	D1	D2
	(mm)	10.60 ± 0.10	10.60 ± 0.10	1.95 ± 0.10	1.50 + 0.10 - 0.00	330 ± 1.00	100.00 ± 0.50	13.00 + 0.50 - 0.00
	(inch)	0.417 ± 0.004	0.417 ± 0.004	0.077 ± 0.004	0.059 + 0.004 - 0.000	12.992 ± 0.039	3.937 ± 0.020	0.512 + 0.020 - 0.000

HBS	SYMBOL	E	F	P	P0	P1	T	W	W1
	(mm)	1.75 ± 0.10	11.50 ± 0.10	12.00 ± 0.10	4.00 ± 0.10	2.00 ± 0.10	0.30 ± 0.05	24.00 ± 0.30	28.50 Max
	(inch)	0.069 ± 0.004	0.453 ± 0.004	0.472 ± 0.004	0.157 ± 0.004	0.079 ± 0.004	0.012 ± 0.002	0.945 ± 0.012	1.122 Max

Company reserves the right to improve product design, functions and reliability without notice.

REV:A