

HCSP-1BS

Automotive Open Loop Current Sensor - Busbar Mounting



KEY FEATURES

- ▶ Open loop current transducer based on Hall effect
- ▶ Busbar mounting
- ▶ Simple analog ratiometric output
- ▶ Measured current value from ± 200 A to ± 1.500 A
- ▶ Non-intrusive technology
- ▶ Galvanic separation between power and control
- ▶ Operating temperature from -40°C to $+125^{\circ}\text{C}$

DESCRIPTION

Piher Sensing Systems' HCSP1BS family of open loop current sensors generates a ratiometric analog output voltage signal proportional to the current flowing through the conductor. Based on Hall effect technology the sensor has been designed for accurate measurement of AC and DC currents in automotive battery management and motor control applications.

APPLICATIONS

- ▶ Battery management
- ▶ Motor control
- ▶ EV motor inverters
- ▶ DC/DC converters

SPECIFICATIONS

Parameter	Unit	Min.	Typ.	Max.
Supply voltage	V	4,5	5	5,5
Supply current	mA	9	12	14
Output voltage	V	0,5		4,5
Offset voltage	V		2,5	
Response time	μsec			3
Frequency bandwidth	kHz	70		250
Operating temperature	$^{\circ}\text{C}$	-40		+125
Typical error (at 25°C ; $V_{cc} = 5\text{V}$)	%	0,65		2,5
Max. error (at -40°C to $+125^{\circ}\text{C}$; $V_{cc} = 5\text{V}$)	%	1		3,5

Other specification on request

HCSP-1BS

Automotive Open Loop Current Sensor - Busbar Mounting

DIMENSIONS (IN MM)

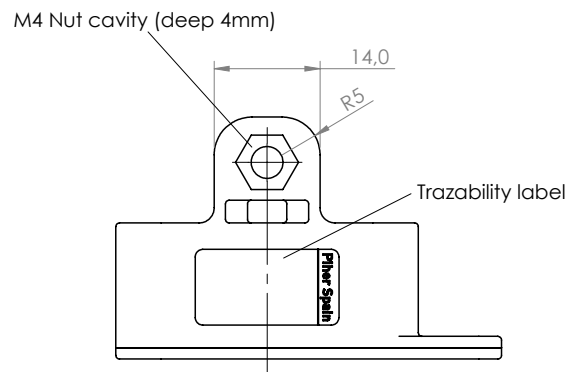
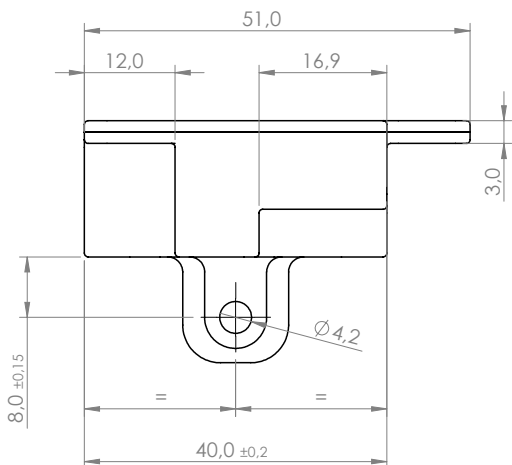
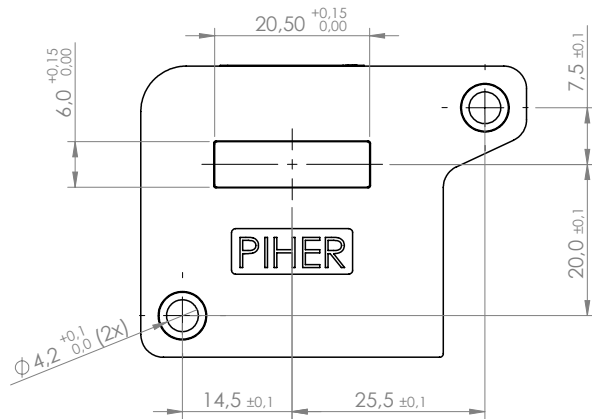
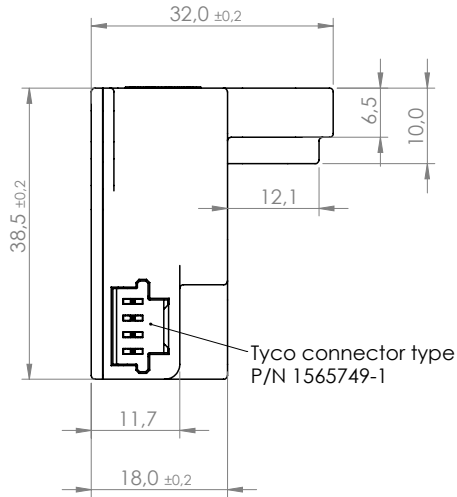
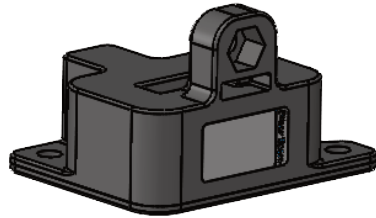
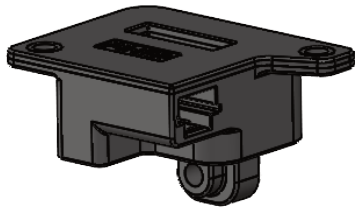

MOUNTING AND CONNECTIONS

Connections		Mounting Recommendation	
Mating connector	TYCO 1473672-1	<ul style="list-style-type: none"> -M4 screw -Spring washer -M4 nut (acc. to ISO 4032) -Max Torque: 2Nm 	
1	Signal output		
2	Supply voltage		
3	Ground		
4	n/c		