



PART NAME

HEAVY DUTY PLASTIC NEMA BOX

PART No.

HD-7602

REVISION DATE

2-23-15

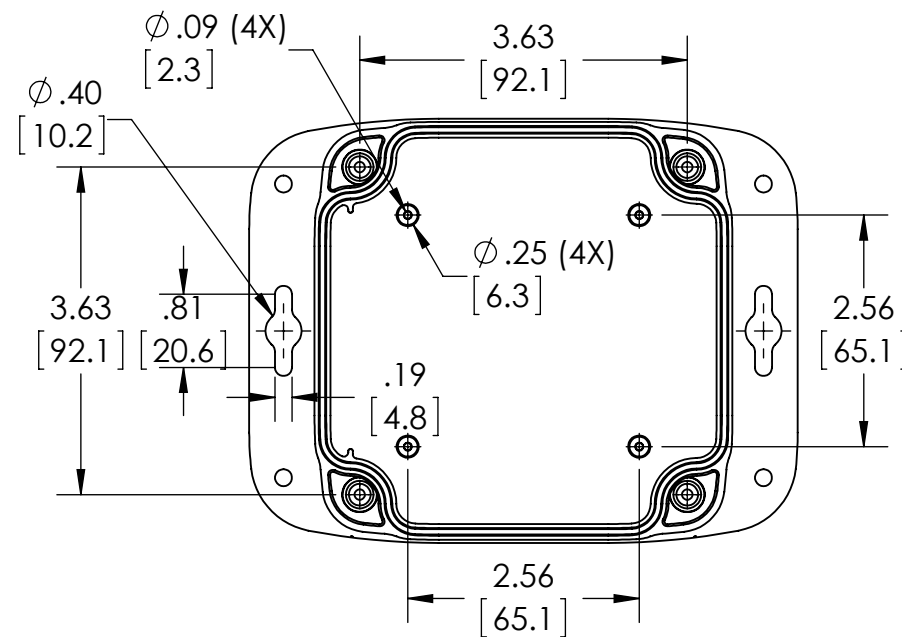
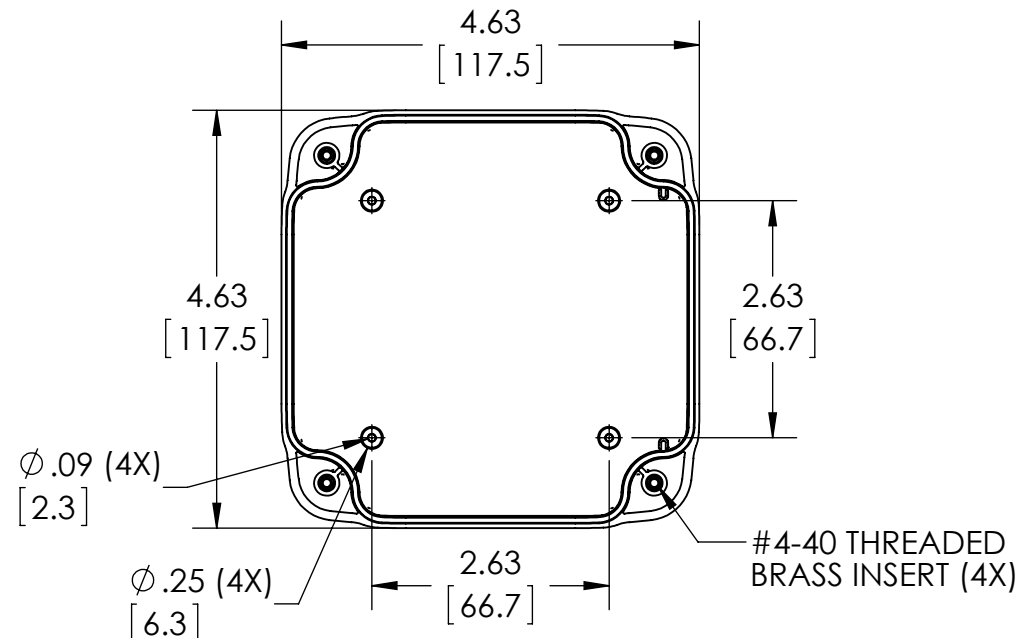
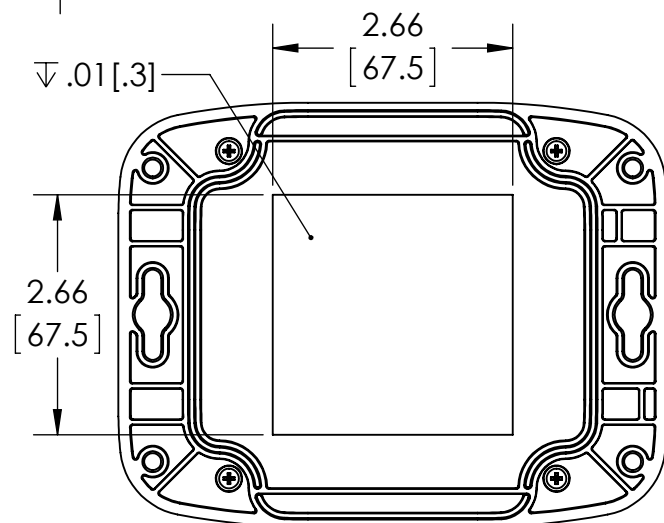
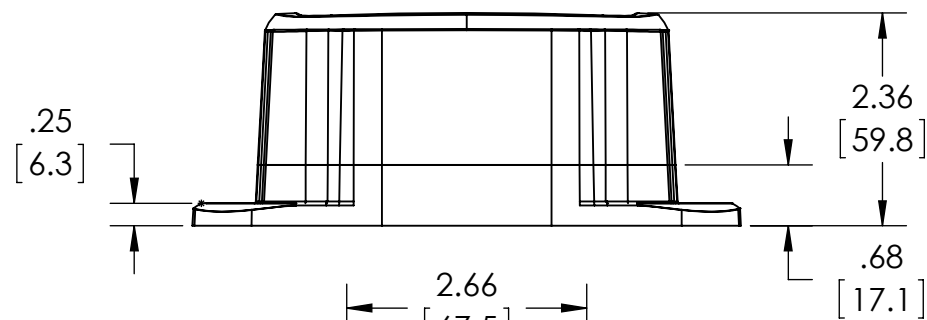
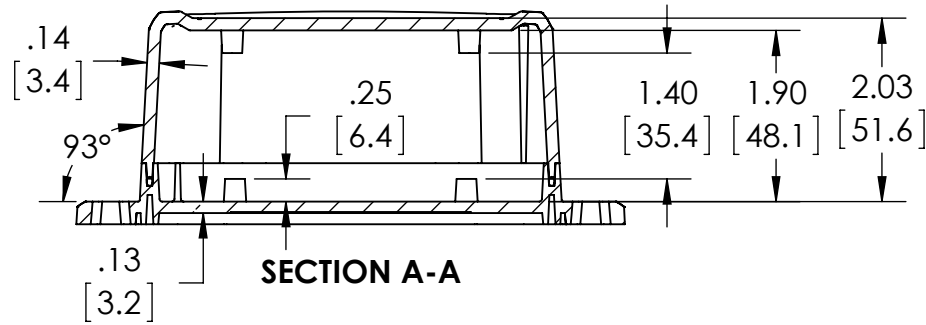
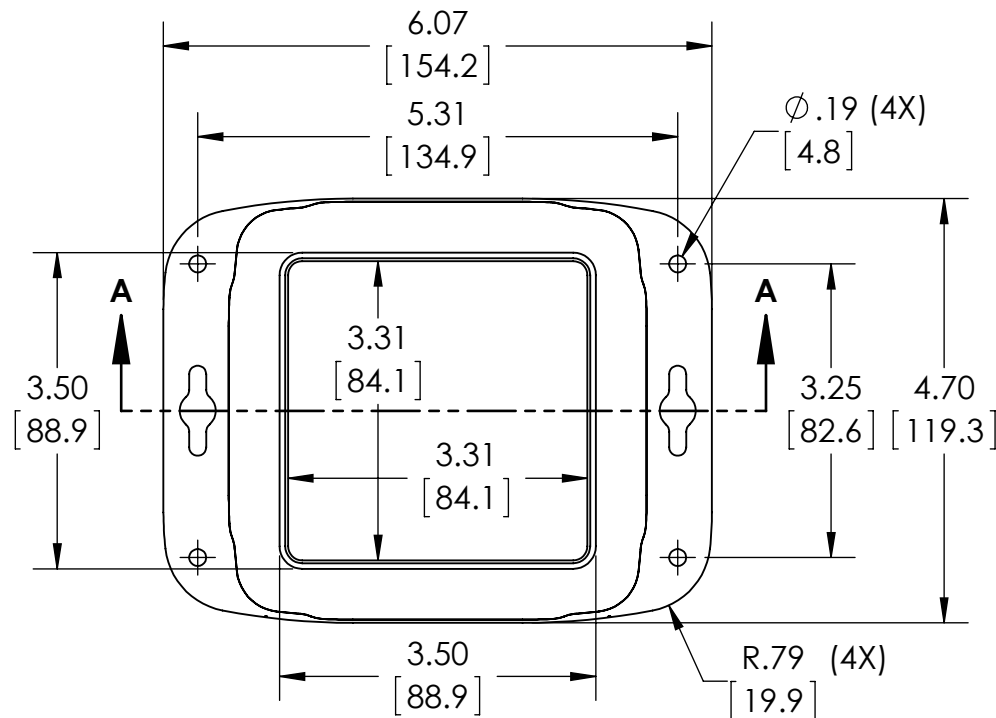

DRAWING FOR REFERENCE

MATERIAL: BASE & COVER - POLYCARBONATE
UL94V-0 AND UV STABILIZED
FINISH: TEXTURED BLACK
GASKET SILICONE RUBBER

ENCLOSURE DESIGNED TO IP 66 OF IEC 529
AND NEMA 4, 4X, 12, 13
FOUR (4) #4-40 x 7/8 LG. PAN HEAD STAINLESS
STEEL SCREWS SUPPLIED FOR ASSEMBLY OF COVER
RECOMMENDED TORQUE SETTING FOR ASSEMBLY
SCREWS : 6.25 IN-LBS.
PCB BOSSES WILL ACCEPT A #4 x 1/4 LG. THREAD
FORMING SCREW (NOT SUPPLIED)

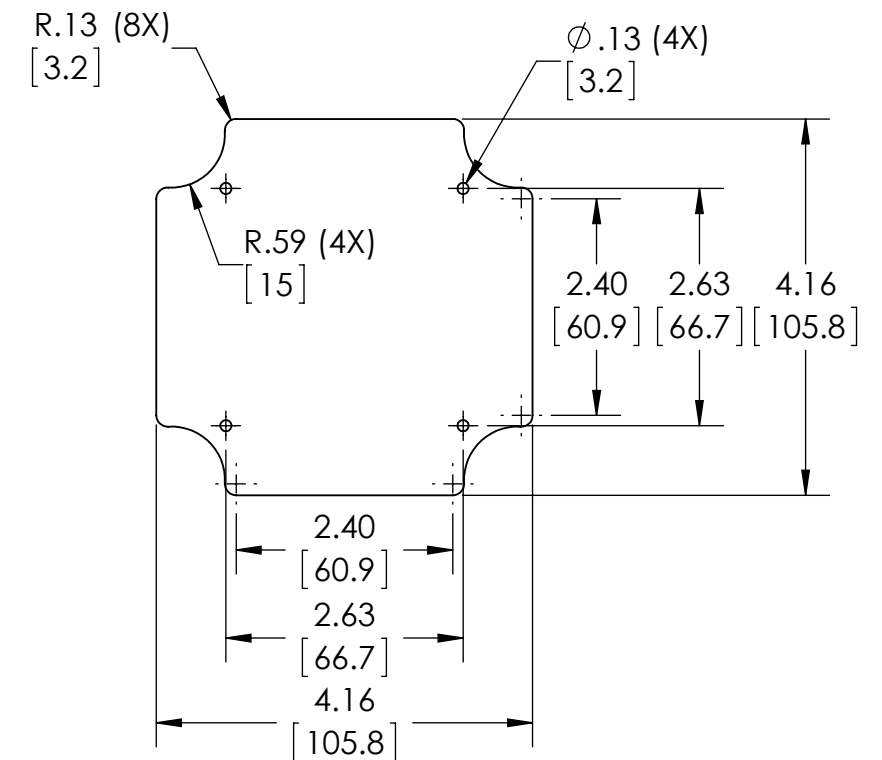

REFERENCE MAXIMUM COVER P.C.B. SIZE
SIZES INCLUDE .03 [.8] CLEARANCE FROM INNER WALLS
AND SCREW TOWERS WHEN UTILIZING THE MOUNTING
BOSSES IN THE COVER. (P.C.B.S NOT SUPPLIED)

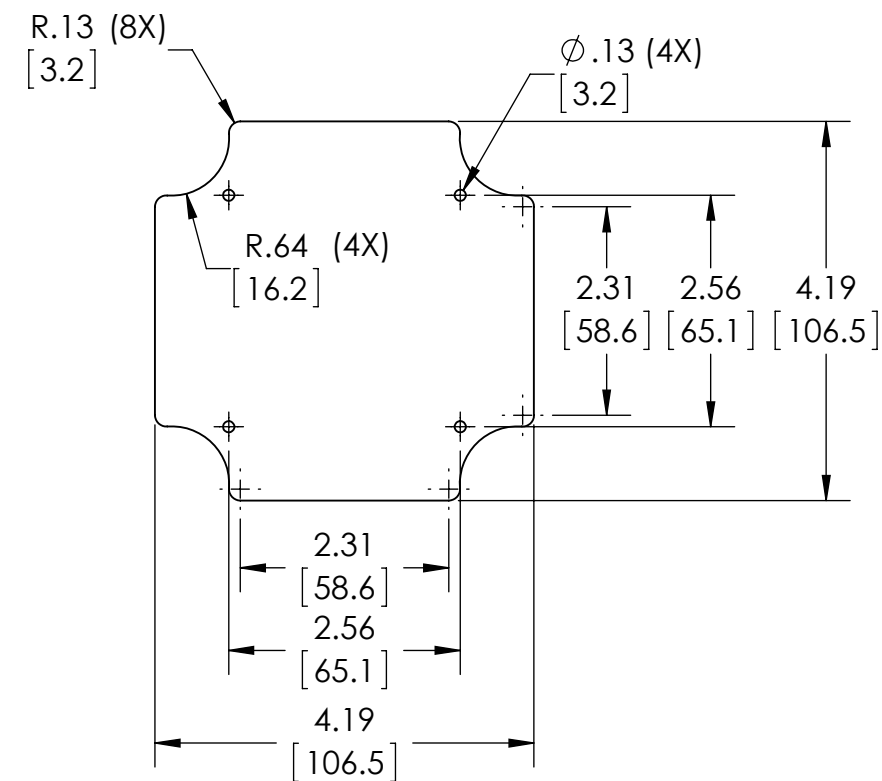

REFERENCE MAXIMUM BASE P.C.B. SIZE

