

HEF4047B-Q100

Monostable/astable multivibrator

Rev. 1 — 17 March 2017

Product data sheet

1 General description

The HEF4047B-Q100 is a retriggerable astable multivibrator that can be configured as either a positive-edge or negative-edge triggered monostable multivibrator. The output pulse width is programmed by selection of external components (R_t and C_t). Inputs include clamp diodes. This enables the use of current limiting resistors to interface inputs to voltages in excess of V_{CC} .

This product has been qualified to the Automotive Electronics Council (AEC) standard Q100 (Grade 3) and is suitable for use in automotive applications.

2 Features and benefits

2.1 General

- Automotive product qualification in accordance with AEC-Q100 (Grade 3)
 - Specified from $-40\text{ }^{\circ}\text{C}$ to $+85\text{ }^{\circ}\text{C}$
- Monostable (one-shot) or astable (free-running) operation
- True and complemented buffered outputs
- Only one external resistor and capacitor required
- ESD protection:
 - MIL-STD-883, method 3015 exceeds 2000 V
 - HBM JESD22-A114F exceeds 2000 V
 - MM JESD22-A115-A exceeds 200 V ($C = 200\text{ pF}$, $R = 0\text{ }\Omega$)

2.2 Monostable multivibrator

- Positive- or negative-edge triggering
- Output pulse width independent of trigger pulse duration
- Retriggerable option for pulse-width expansion
- Long pulse width possible using small RC components with external counter provision
- Fast recovery time independent of pulse width
- Pulse-width accuracy maintained at duty cycles approaching 100%

2.3 Astable multivibrator

- Free-running or gatable operating modes
- 50% duty cycle
- Oscillator output available

3 Ordering information

Table 1. Ordering information

Type number	Package		Version
	Name	Description	
HEF4047BT-Q100	SO14	plastic small outline package; 14 leads; body width 3.9 mm	SOT108-1

4 Functional diagram

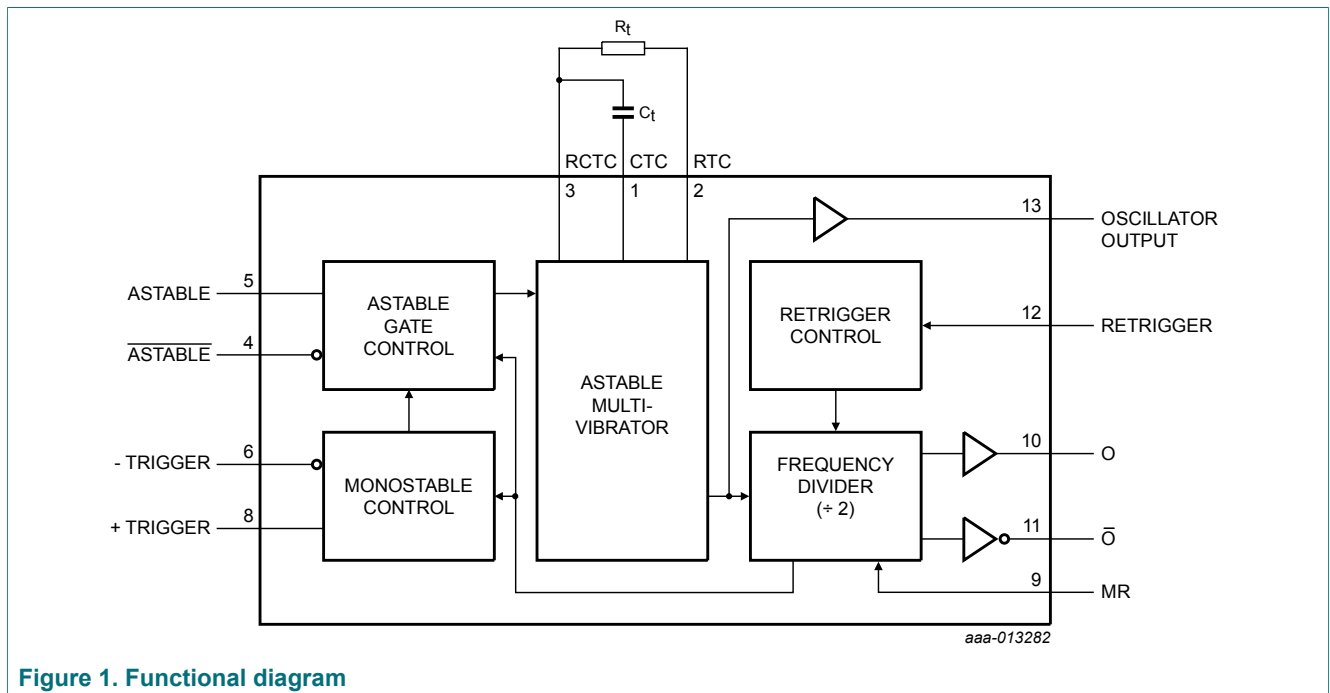
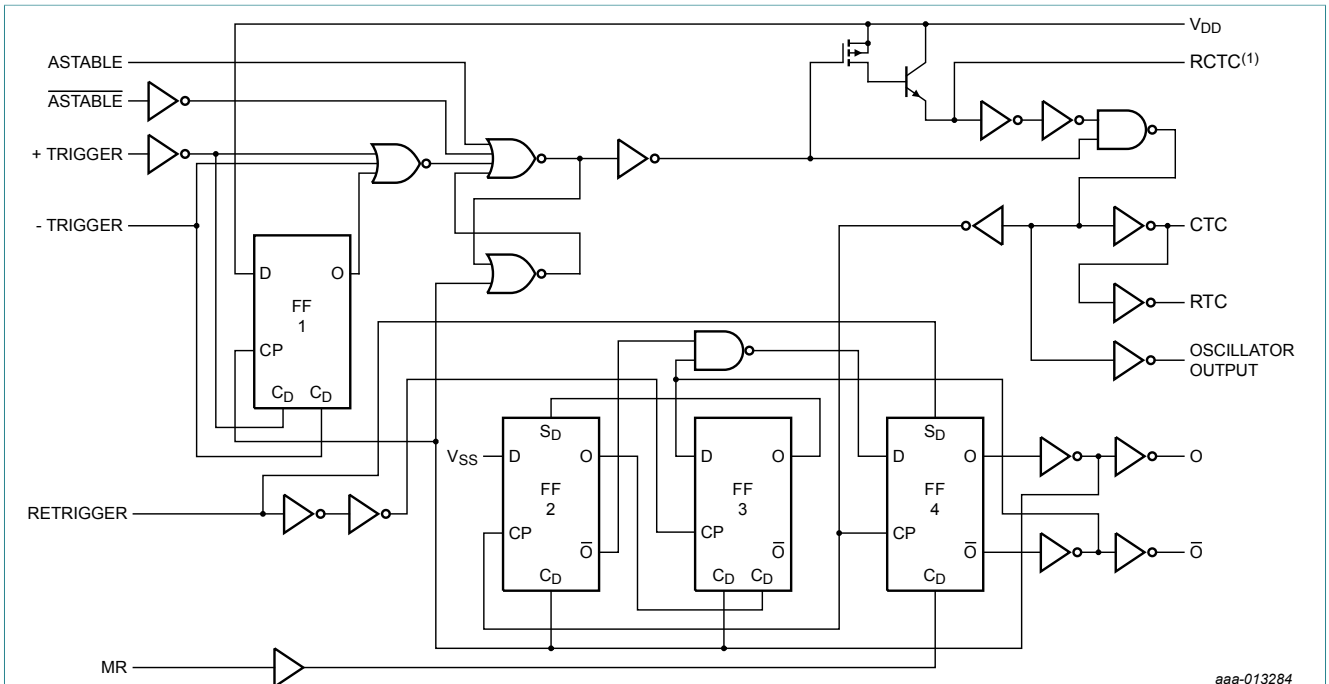

Figure 1. Functional diagram



aaa-013284

(1) Special input protection that allows operating input voltages outside the supply voltage lines. Compared to the standard input protection pin 3 (RCTC) is more sensitive to static discharge; extra handling precautions are recommended.

Figure 2. Logic diagram

5 Pinning information

5.1 Pinning

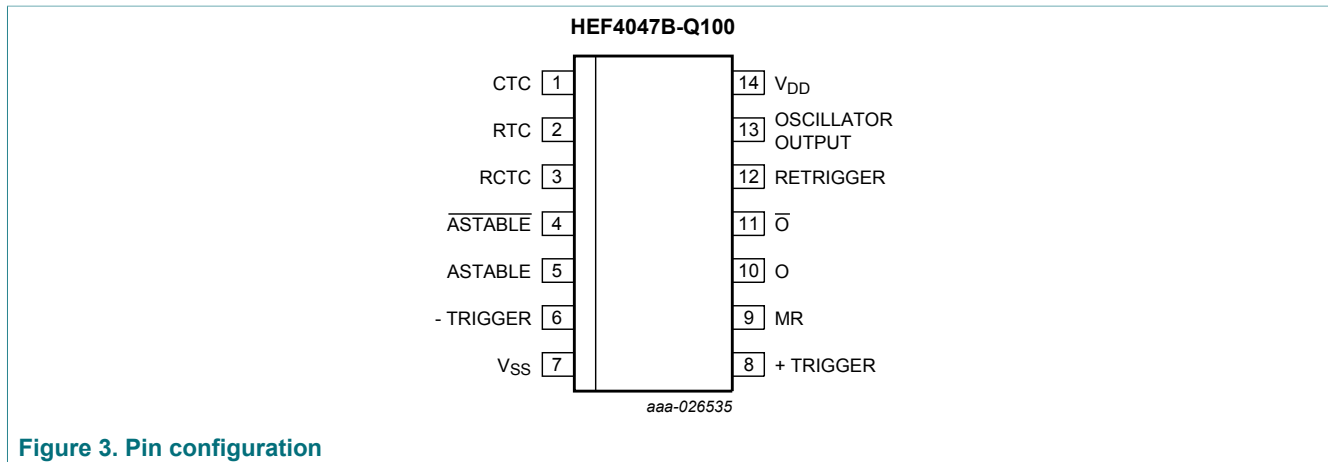

Figure 3. Pin configuration

5.2 Pin description

Table 2. Pin description

Symbol	Pin	Description
CTC	1	external capacitor connection
RTC	2	external resistor connection
RCTC	3	external capacitor/resistor connection
$\overline{\text{ASTABLE}}$	4	input
ASTABLE	5	input
-TRIGGER	6	input
V _{SS}	7	ground supply voltage
+TRIGGER	8	input
MR	9	master reset input
O	10	output
$\overline{\text{O}}$	11	output
RETRIGGER	12	input
OSCILLATOR OUTPUT	13	oscillator output
V _{DD}	14	supply voltage

6 Functional description

The HEF4047B-Q100 consists of a gate-able astable multivibrator incorporating logic techniques to permit positive or negative edge-triggered monostable multivibrator action with retriggering and external counting options.

Inputs include +TRIGGER, -TRIGGER, ASTABLE, $\overline{\text{ASTABLE}}$, RETRIGGER and MR (master reset). Buffered outputs are O, $\overline{\text{O}}$ and OSCILLATOR OUTPUT. In all modes of operation an external capacitor (C_T) must be connected between CTC and RCTC, and an external resistor (R_T) must be connected between RTC and RCTC.

A HIGH level on the ASTABLE input enables astable operation. The period of the square wave at O and $\overline{\text{O}}$ outputs is a function of the external components employed. 'True' input pulses on the ASTABLE or 'complement' pulses on the $\overline{\text{ASTABLE}}$ input, allow the circuit to be used as a gate-able multivibrator. The OSCILLATOR OUTPUT period is half of the O output in the astable mode. However, a 50% duty factor is not guaranteed at this output.

In the monostable mode, positive edge-triggering is accomplished by applying a leading-edge pulse to the +TRIGGER input and a LOW level to the -TRIGGER input. For negative edge-triggering, a trailing-edge pulse is applied to the -TRIGGER and a HIGH level to the +TRIGGER. Input pulses may be of any duration relative to the output pulse. The multivibrator can be retriggered (on the leading-edge only) by applying a common pulse to both the RETRIGGER and +TRIGGER inputs. In this mode, the output pulse remains HIGH as long as the input pulse period is shorter than the period determined by the RC components.

An external count down option implements coupling O to an external 'N' counter and resetting the counter with the trigger pulse. The counter output pulse is fed back to the $\overline{\text{ASTABLE}}$ input and has a duration equal to N times the period of the multivibrator. A HIGH level on the MR input assures no output pulse during an ON-power condition. This input can also be activated to terminate the output pulse at any time. In the monostable mode, a HIGH level or power-ON reset pulse must be applied to MR, whenever V_{DD} is applied.

7 Limiting values

Table 3. Limiting values

In accordance with the Absolute Maximum Rating System (IEC 60134). Voltages are referenced to $V_{SS} = 0$ V (ground).

Symbol	Parameter	Conditions	Min	Max	Unit
V_{DD}	supply voltage		-0.5	+18	V
I_{IK}	input clamping current	$V_I < -0.5$ V or $V_I > V_{DD} + 0.5$ V	-	± 10	mA
V_I	input voltage		-0.5	$V_{DD} + 0.5$	V
I_{OK}	output clamping current	$V_O < -0.5$ V or $V_O > V_{DD} + 0.5$ V	-	± 10	mA
$I_{I/O}$	input/output current		-	± 10	mA
I_{DD}	supply current		-	50	mA
T_{stg}	storage temperature		-65	+150	°C
T_{amb}	ambient temperature		-40	+85	°C
P_{tot}	total power dissipation	$T_{amb} = -40$ °C to +85 °C			
		SO14 package [1]	-	500	mW
P	power dissipation	per output	-	100	mW

[1] For SO14 package: P_{tot} derates linearly with 8 mW/K above 70 °C.

8 Recommended operating conditions

Table 4. Operating conditions

Symbol	Parameter	Conditions	Min	Max	Unit
V_{DD}	supply voltage		3	15	V
V_I	input voltage		0	V_{DD}	V
T_{amb}	ambient temperature	in free air	-40	+85	°C
$\Delta t/\Delta V$	input transition rise and fall rate	$V_{DD} = 5$ V	-	3.75	$\mu\text{s/V}$
		$V_{DD} = 10$ V	-	0.5	$\mu\text{s/V}$
		$V_{DD} = 15$ V	-	0.08	$\mu\text{s/V}$

9 Static characteristics

Table 5. Static characteristics

$V_{SS} = 0\text{ V}$; $V_I = V_{SS}$ or V_{DD} unless otherwise specified.

Symbol	Parameter	Conditions	V_{DD}	$T_{amb} = -40\text{ °C}$		$T_{amb} = 25\text{ °C}$		$T_{amb} = 85\text{ °C}$		Unit
				Min	Max	Min	Max	Min	Max	
V_{IH}	HIGH-level input voltage	$ I_O < 1\text{ }\mu\text{A}$	5 V	3.5	-	3.5	-	3.5	-	V
			10 V	7.0	-	7.0	-	7.0	-	V
			15 V	11.0	-	11.0	-	11.0	-	V
V_{IL}	LOW-level input voltage	$ I_O < 1\text{ }\mu\text{A}$	5 V	-	1.5	-	1.5	-	1.5	V
			10 V	-	3.0	-	3.0	-	3.0	V
			15 V	-	4.0	-	4.0	-	4.0	V
V_{OH}	HIGH-level output voltage	$ I_O < 1\text{ }\mu\text{A}$	5 V	4.95	-	4.95	-	4.95	-	V
			10 V	9.95	-	9.95	-	9.95	-	V
			15 V	14.95	-	14.95	-	14.95	-	V
V_{OL}	LOW-level output voltage	$ I_O < 1\text{ }\mu\text{A}$	5 V	-	0.05	-	0.05	-	0.05	V
			10 V	-	0.05	-	0.05	-	0.05	V
			15 V	-	0.05	-	0.05	-	0.05	V
I_{OH}	HIGH-level output current	$V_O = 2.5\text{ V}$	5 V	-	-1.7	-	-1.4	-	-1.1	mA
		$V_O = 4.6\text{ V}$	5 V	-	-0.52	-	-0.44	-	-0.36	mA
		$V_O = 9.5\text{ V}$	10 V	-	-1.3	-	-1.1	-	-0.9	mA
		$V_O = 13.5\text{ V}$	15 V	-	-3.6	-	-3.0	-	-2.4	mA
I_{OL}	LOW-level output current	$V_O = 0.4\text{ V}$	5 V	0.52	-	0.44	-	0.36	-	mA
		$V_O = 0.5\text{ V}$	10 V	1.3	-	1.1	-	0.9	-	mA
		$V_O = 1.5\text{ V}$	15 V	3.6	-	3.0	-	2.4	-	mA
I_I	input leakage current		15 V	-	± 0.3	-	± 0.3	-	± 1.0	μA
		output transistor OFF; pin 3 at V_{DD} or V_{SS}	15 V	-	± 0.3	-	± 0.3	-	± 1.0	μA
I_{DD}	supply current	$I_O = 0\text{ A}$	5 V	-	20	-	20	-	150	μA
			10 V	-	40	-	40	-	300	μA
			15 V	-	80	-	80	-	600	μA
C_I	input capacitance		-	-	-	7.5	-	-	pF	

10 Dynamic characteristics

Table 6. Dynamic characteristics
 $V_{SS} = 0\text{ V}$; $T_{amb} = 25\text{ °C}$; unless otherwise specified; for waveform and test circuit, see [Figure 4](#) and [Figure 5](#).

Symbol	Parameter	Conditions	V _{DD}	Extrapolation formula	Min	Typ	Max	Unit
t _{PHL}	HIGH to LOW propagation delay	ASTABLE, $\overline{\text{ASTABLE}}$ to OSCILLATOR OUTPUT	5 V ^[1]	68 ns + (0.55 ns/pF)C _L	-	95	190	ns
			10 V ^[1]	43 ns + (0.23 ns/pF)C _L	-	45	90	ns
			15 V ^[1]	22 ns + (0.16 ns/pF)C _L	-	30	60	ns
t _{PLH}	LOW to HIGH propagation delay	ASTABLE, $\overline{\text{ASTABLE}}$ to OSCILLATOR OUTPUT	5 V ^[1]	58 ns + (0.55 ns/pF)C _L	-	85	170	ns
			10 V	29 ns + (0.23 ns/pF)C _L	-	40	80	ns
			15 V	22 ns + (0.16 ns/pF)C _L	-	30	60	ns
t _{PHL}	HIGH to LOW propagation delay	ASTABLE, $\overline{\text{ASTABLE}}$ to O, $\overline{\text{O}}$	5 V ^[1]	123 ns + (0.55 ns/pF)C _L	-	150	300	ns
			10 V	54 ns + (0.23 ns/pF)C _L	-	65	130	ns
			15 V	42 ns + (0.16 ns/pF)C _L	-	50	100	ns
t _{PLH}	LOW to HIGH propagation delay	ASTABLE, $\overline{\text{ASTABLE}}$ to O, $\overline{\text{O}}$	5 V ^[1]	103 ns + (0.55 ns/pF)C _L	-	130	260	ns
			10 V	49 ns + (0.23 ns/pF)C _L	-	60	120	ns
			15 V	37 ns + (0.16 ns/pF)C _L	-	45	90	ns
t _{PHL}	HIGH to LOW propagation delay	+/-TRIGGER to O, $\overline{\text{O}}$	5 V ^[1]	133 ns + (0.55 ns/pF)C _L	-	160	320	ns
			10 V	54 ns + (0.23 ns/pF)C _L	-	65	130	ns
			15 V	42 ns + (0.16 ns/pF)C _L	-	50	100	ns
t _{PLH}	LOW to HIGH propagation delay	+/-TRIGGER to O, $\overline{\text{O}}$	5 V ^[1]	128 ns + (0.55 ns/pF)C _L	-	155	310	ns
			10 V	54 ns + (0.23 ns/pF)C _L	-	65	130	ns
			15 V	42 ns + (0.16 ns/pF)C _L	-	50	100	ns
t _{PHL}	HIGH to LOW propagation delay	+TRIGGER, RETRIGGER to $\overline{\text{O}}$	5 V ^[1]	38 ns + (0.55 ns/pF)C _L	-	65	130	ns
			10 V	19 ns + (0.23 ns/pF)C _L	-	30	60	ns
			15 V	17 ns + (0.16 ns/pF)C _L	-	25	50	ns
t _{PLH}	LOW to HIGH propagation delay	+TRIGGER, RETRIGGER to O	5 V ^[1]	68 ns + (0.55 ns/pF)C _L	-	95	190	ns
			10 V	29 ns + (0.23 ns/pF)C _L	-	40	80	ns
			15 V	22 ns + (0.16 ns/pF)C _L	-	30	60	ns
t _{PHL}	HIGH to LOW propagation delay	MR to O	5 V ^[1]	83 ns + (0.55 ns/pF)C _L	-	100	200	ns
			10 V	34 ns + (0.23 ns/pF)C _L	-	45	90	ns
			15 V	27 ns + (0.16 ns/pF)C _L	-	35	70	ns
t _{PLH}	LOW to HIGH propagation delay	MR to $\overline{\text{O}}$	5 V ^[1]	83 ns + (0.55 ns/pF)C _L	-	100	200	ns
			10 V	34 ns + (0.23 ns/pF)C _L	-	45	90	ns
			15 V	27 ns + (0.16 ns/pF)C _L	-	35	70	ns
t _{THL}	HIGH to LOW output transition time		5 V ^[1]	10 ns + (1.0 ns/pF)C _L	-	60	120	ns
			10 V	9 ns + (0.42 ns/pF)C _L	-	30	60	ns
			15 V	6 ns + (0.28 ns/pF)C _L	-	20	40	ns

Symbol	Parameter	Conditions	V _{DD}	Extrapolation formula	Min	Typ	Max	Unit
t _{TLH}	LOW to HIGH output transition time		5 V ^[1]	10 ns + (1.0 ns/pF)C _L	-	60	120	ns
			10 V	9 ns + (0.42 ns/pF)C _L	-	30	60	ns
			15 V	6 ns + (0.28 ns/pF)C _L	-	20	40	ns
t _w	pulse width	any input except MR	5 V	-	220	110	-	ns
			10 V	-	100	50	-	ns
			15 V	-	70	35	-	ns
		MR HIGH	5 V	-	60	30	-	ns
			10 V	-	30	15	-	ns
			15 V	-	20	10	-	ns

[1] The typical values of the propagation delay and transition times are calculated from the extrapolation formulas shown (C_L in pF).

10.1 Waveform and test circuit

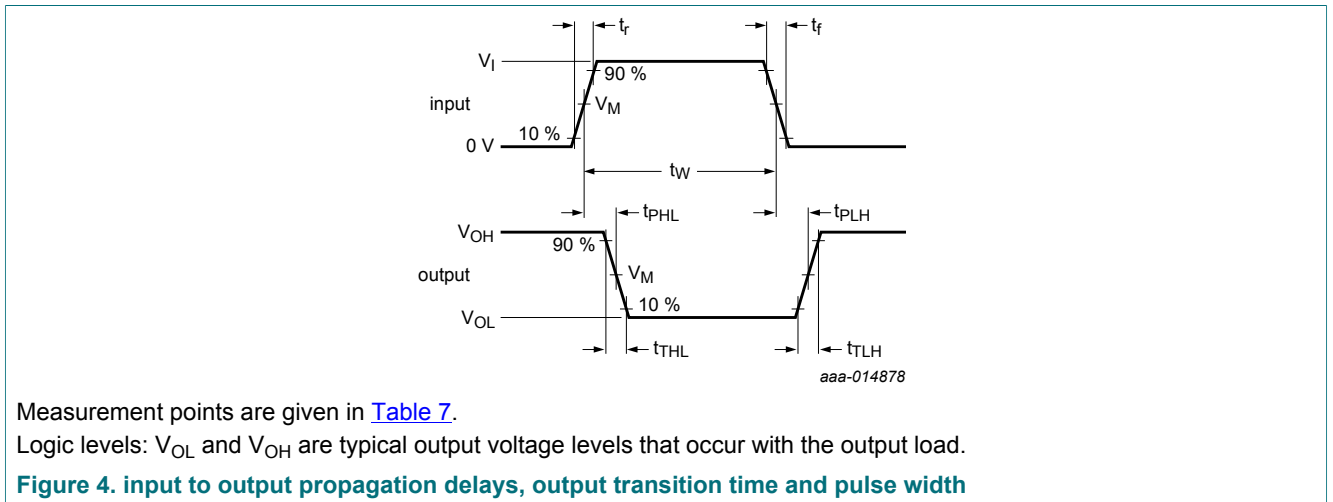
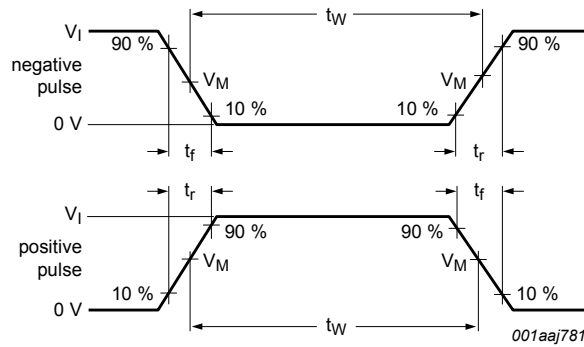
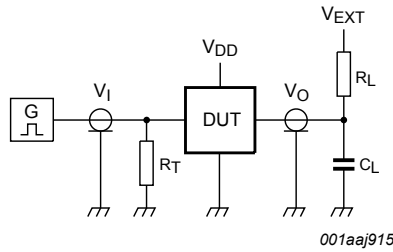

Table 7. Measurement points

Supply voltage	Input	Output
V _{DD}	V _M	V _M
5 V to 15 V	0.5V _{DD}	0.5V _{DD}



a. Input waveform



b. Test circuit

Test and measurement data is given in [Table 8](#).

Definitions test circuit:

R_T = Termination resistance should be equal to output impedance Z_o of the pulse generator.

C_L = Load capacitance including jig and probe capacitance.

Figure 5. Test circuit for measuring switching times

Table 8. Test data

Supply voltage	Input		Load		V_{EXT}
	V_I	t_r, t_f	C_L	R_L	t_{PLH}, t_{PHL}
5 V to 15 V	V_{DD}	≤ 20 ns	50 pF	1 k Ω	open

11 Application information

Table 9. Functional connections ^[1]

Function	Pins connected to			Output pulse from pins	Output period or pulse width
	V _{DD}	V _{SS}	input pulse		
Astable multivibrator					
Free running	4, 5, 6, 14	7, 8, 9, 12	-	10, 11, 13	at pins 10, 11; $t_A = 4.40 R_t C_t$ at pin 13; $t_A = 2.20 R_t C_t$
True gating	4, 6, 14	7, 8, 9, 12	5	10, 11, 13	
Complement gating	6, 14	5, 7, 8, 9, 12	4	10, 11, 13	
Monostable multivibrator					
Positive edge-triggering	4, 14	5, 6, 7, 9, 12	8	10, 11	at pins 10, 11; $t_M = 2.48 R_t C_t$
Negative edge-triggering	4, 8, 14	5, 7, 9, 12	6	10, 11	
Retriggerable	4, 14	5, 6, 7, 9	8, 12	10, 11	
External countdown ^[2]	14	5, 6, 7, 8, 9, 12	-	10, 11	

[1] In all cases, external resistor between pins 2 and 3, external capacitor between pins 1 and 3.

[2] Input pulse to RESET of external counting chip; external counting chip output to pin 4.

11.1 Astable mode design information

11.1.1 Unit-to-unit transfer voltage variations

The following analysis presents worst case variations from unit-to-unit as a function of transfer voltage (V_{TR}) shift for free running (astable) operation.

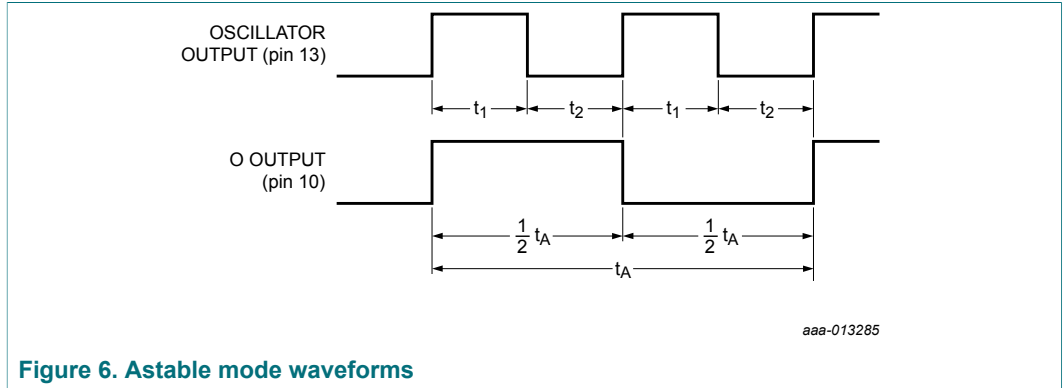

Figure 6. Astable mode waveforms

$$(1) \quad t_1 = -R_t C_t \ln \frac{V_{TR}}{V_{DD} + V_{TR}}$$

$$(2) \quad t_2 = -R_t C_t \ln \frac{V_{DD} - V_{TR}}{2V_{DD} - V_{TR}}$$

$$(3) \quad t_A = 2(t_1 + t_2) = -2R_t C_t \ln \frac{(V_{TR})(V_{DD} - V_{TR})}{(V_{DD} + V_{TR})(2V_{DD} - V_{TR})}$$

, where t_A = astable mode pulse width; see [Table 10](#).

Table 10. Values for astable mode pulse width (t_A)

	V_{TR}			t_A		
	Min	Typ	Max	Min	Typ ^[1]	Max
$V_{DD} = 5 \text{ V or } 10 \text{ V}$	$0.3 \times V_{DD}$	$0.5 \times V_{DD}$	$0.7 \times V_{DD}$	$4.71 R_t C_t$	$4.40 R_t C_t$	$4.71 R_t C_t$
$V_{DD} = 15 \text{ V}$	4 V	$0.5 \times V_{DD}$	11 V	$4.84 R_t C_t$	$4.40 R_t C_t$	$4.84 R_t C_t$

[1] Therefore if $t_A = 4.40 R_t C_t$ is used, the maximum variation is (+7.0%; -0.0%) at 10 V.

11.1.2 Variations due to changes in V_{DD}

In addition to variations from unit-to-unit, the astable period may vary as a function of frequency with respect to V_{DD} . Typical variations are presented graphically in [Figure 7](#) and [Figure 8](#) with 10 V as a reference.

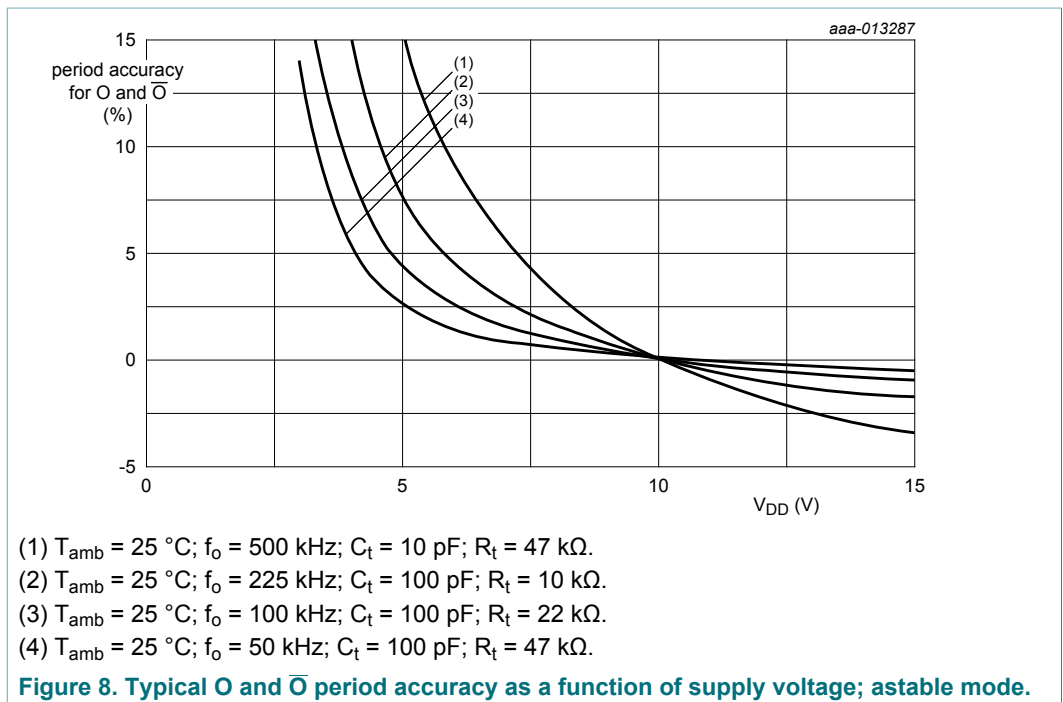
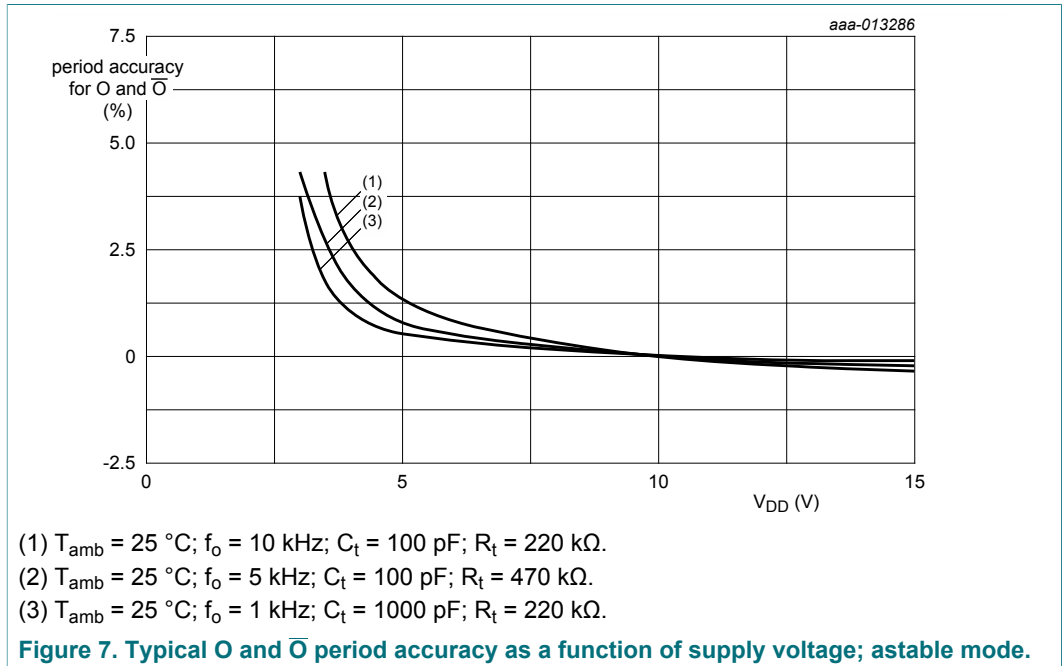

11.2 Monostable mode design information

The following analysis presents worst case variations from unit-to-unit as a function of transfer voltage (V_{TR}) shift for one-shot (monostable) operation.

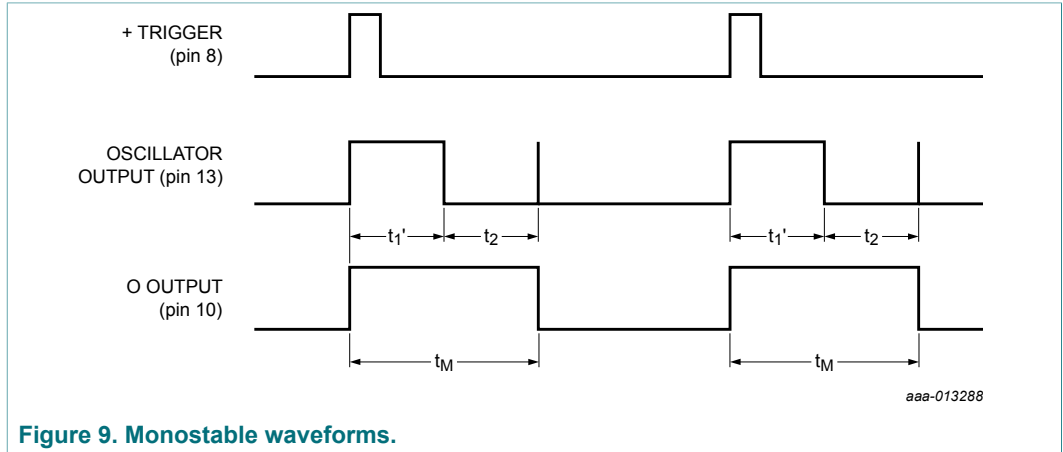

Figure 9. Monostable waveforms.

$$(4) \quad t_1' = -R_t C_t \ln \frac{V_{TR}}{2V_{DD}}$$

$$(5) \quad t_M = (t_1' + t_2)$$

$$(6) \quad t_M = -R_t C_t \ln \frac{(V_{TR})(V_{DD} - V_{TR})}{(2V_{DD} - V_{TR})(2V_{DD})}$$

where t_M = monostable mode pulse width; see table [Table 11](#).

Table 11. Values for monostable mode pulse width (t_M)

	V_{TR}			t_M		
	Min	Typ	Max	Min	Typ ^[1]	Max
$V_{DD} = 5\text{ V or }10\text{ V}$	$0.3 \times V_{DD}$	$0.5 \times V_{DD}$	$0.7 \times V_{DD}$	$2.78 R_t C_t$	$2.48 R_t C_t$	$2.52 R_t C_t$
$V_{DD} = 15\text{ V}$	4 V	$0.5 \times V_{DD}$	11 V	$2.88 R_t C_t$	$2.48 R_t C_t$	$2.56 R_t C_t$

[1] In the astable mode, the first positive half cycle has a duration of t_M ; succeeding durations are $\frac{1}{2} t_A$. Therefore if $t_M = 2.48 R_t C_t$ is used, the maximum variation is (+12%; -0.0%) at 10 V.

11.2.1 Retrigger mode operation

The HEF4047B-Q100 can be used in the retrigger mode to extend the output pulse duration. It can also be used to compare the frequency of an input signal with the frequency of the internal oscillator. In the retrigger mode, the input pulse is applied to pins 8 and 12, and the output is taken from pin 10 or 11. Normal monostable action is obtained when one retrigger pulse is applied (see Figure 10). Extended pulse duration is obtained when more than one pulse is applied. For two input pulses, $t_{RE} = t_1' + t_1 + 2t_2$. For more than two pulses, t_{RE} (output O), terminates at some variable time, t_D , after the termination of the last retrigger pulse. t_D is variable because t_{RE} (output O) terminates after the second positive edge of the oscillator output appears at flip-flop 4.

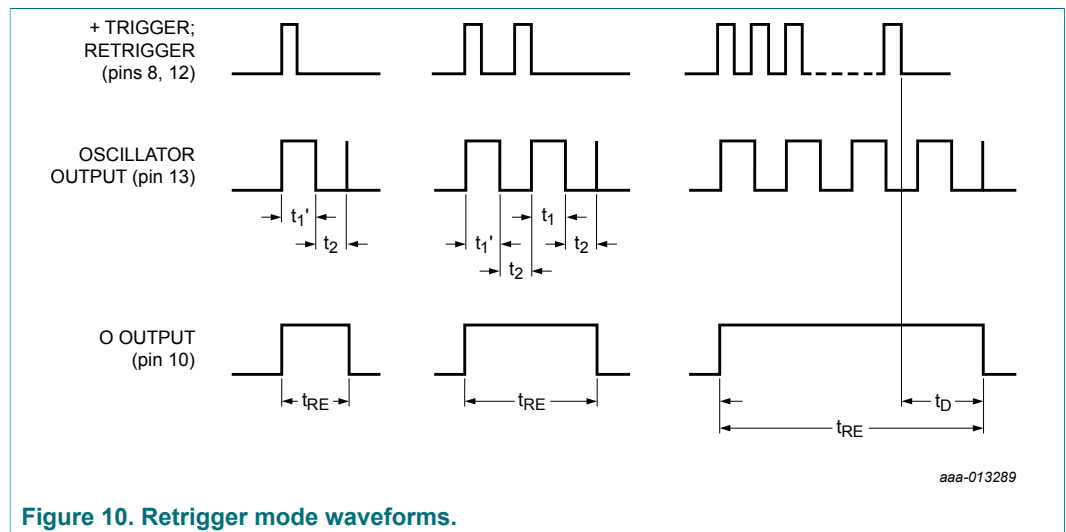

Figure 10. Retrigger mode waveforms.

11.2.2 External counter option

The use of external counting circuitry extends time t_M by any amount. Advantages include digitally controlled pulse duration, small timing capacitors for long time periods, and extremely fast recovery time. A typical implementation is shown in Figure 11.

The pulse duration at the output is:

$$(7) \quad t_{ext} = (N - 1)(t_A) + (t_M + 1/2 t_A)$$

Where t_{ext} = pulse duration of the circuitry, and N is the number of counts used.

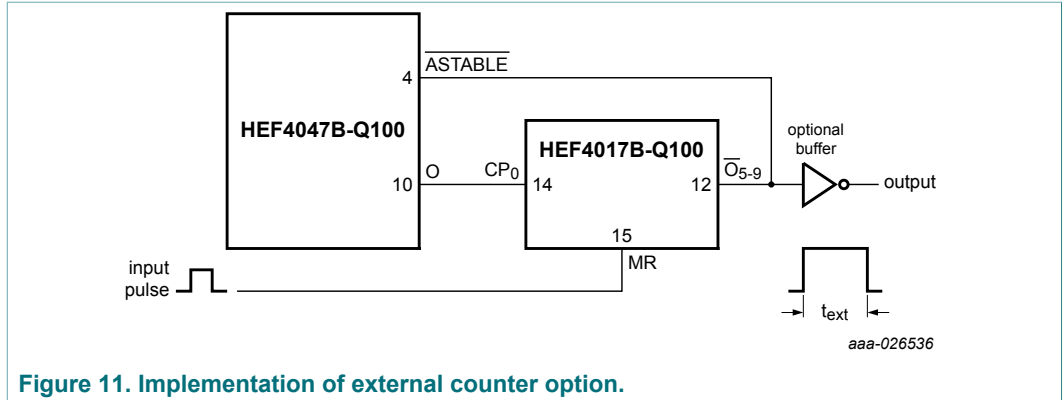

Figure 11. Implementation of external counter option.

11.2.3 Timing component limitations

The capacitor used in the circuit should be non-polarized and have low leakage (that is the parallel resistance of the capacitor should be an order of magnitude greater than the external resistor used). There is no upper or lower limit for either R_t or C_t value to maintain oscillation. However, for accuracy, C_t must be much larger than the inherent stray capacitance in the system (unless this capacitance can be measured and taken into account). R_t must be much larger than the LOCMOS 'ON' resistance in series with it, which typically is hundreds of ohms.

The recommended values for R_t and C_t to comply with previously calculated formulae without trimming should be:

- $C_t \geq 100 \text{ pF}$, up to any practical value
- $10 \text{ k}\Omega \leq R_t \leq 1 \text{ M}\Omega$

11.2.4 Power consumption

In the standby mode (monostable or astable), power dissipation is a function of leakage current in the circuit. For dynamic operation, the power required to charge the external timing capacitor C_t is shown in the following formulae:

Astable mode:

$$(8) \quad P = 2C_t V^2 f \quad (f \text{ at output pin 13})$$

$$(9) \quad P = 4C_t V^2 f \quad (f \text{ at output pins 10 and 11})$$

Monostable mode:

$$(10) \quad P = \frac{(2.9C_t V^2)(\text{duty cycle})}{T} \quad (f \text{ at output pins 10 and 11})$$

Because the power dissipation does not depend on R_t , a design for minimum power dissipation would be a small value of C_t . The value of R would depend on the desired period (within the limitations discussed previously). Typical power consumption in astable mode is shown in [Figure 12](#), [Figure 13](#) and [Figure 14](#).

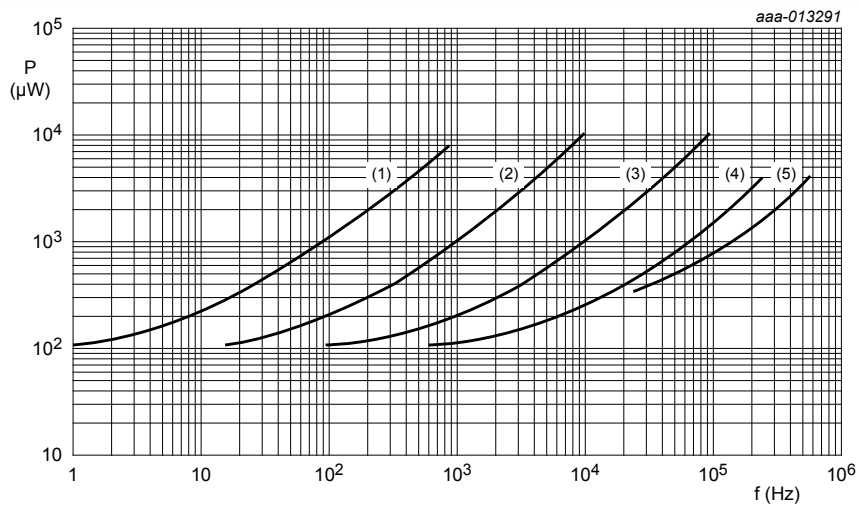

$V_{DD} = 5 \text{ V}$.

(1) $C_t = 100 \text{ nF}$.

(2) $C_t = 10 \text{ nF}$.

(3) $C_t = 1 \text{ nF}$.

(4) $C_t = 100 \text{ pF}$.

(5) $C_t = 10 \text{ pF}$.

Figure 12. Power consumption as a function of the output frequency at O or \bar{O} ; astable mode.

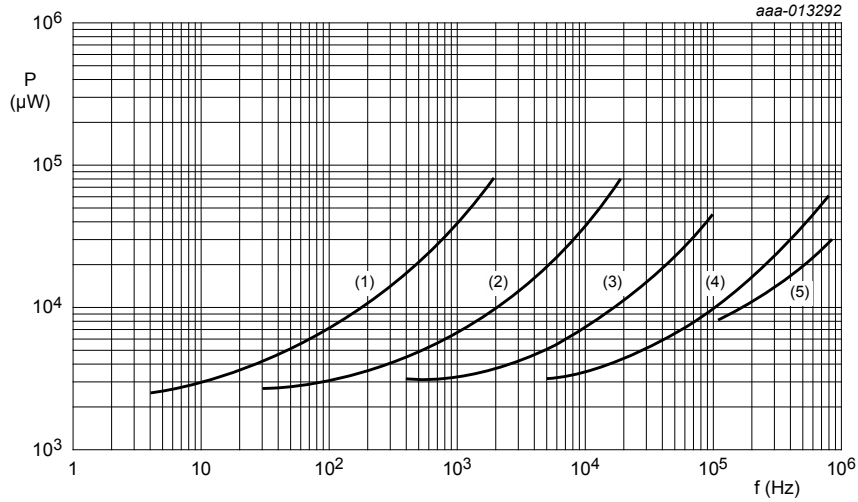

$V_{DD} = 10 \text{ V.}$

(1) $C_t = 100 \text{ nF.}$

(2) $C_t = 10 \text{ nF.}$

(3) $C_t = 1 \text{ nF.}$

(4) $C_t = 100 \text{ pF.}$

(5) $C_t = 10 \text{ pF.}$

Figure 13. Power consumption as a function of the output frequency at O or \bar{O} ; astable mode.

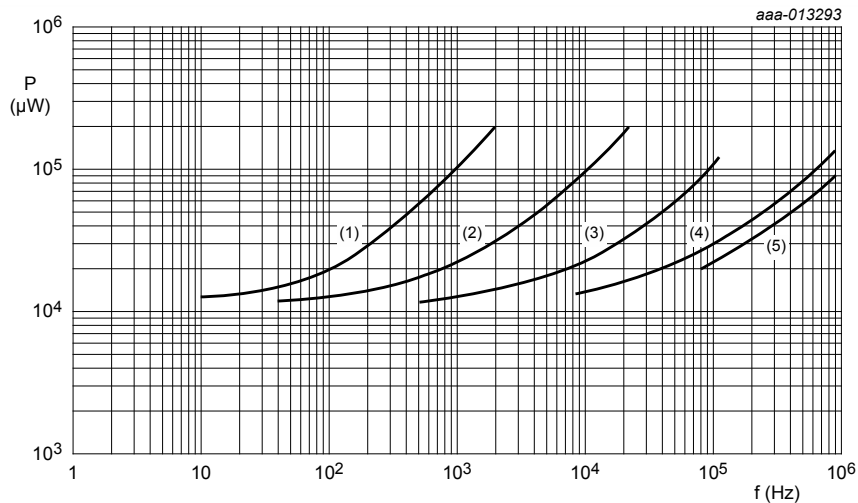

$V_{DD} = 15 \text{ V.}$

(1) $C_t = 100 \text{ nF.}$

(2) $C_t = 10 \text{ nF.}$

(3) $C_t = 1 \text{ nF.}$

(4) $C_t = 100 \text{ pF.}$

(5) $C_t = 10 \text{ pF.}$

Figure 14. Power consumption as a function of the output frequency at O or \bar{O} ; astable mode.

12 Package outline

SO14: plastic small outline package; 14 leads; body width 3.9 mm

SOT108-1

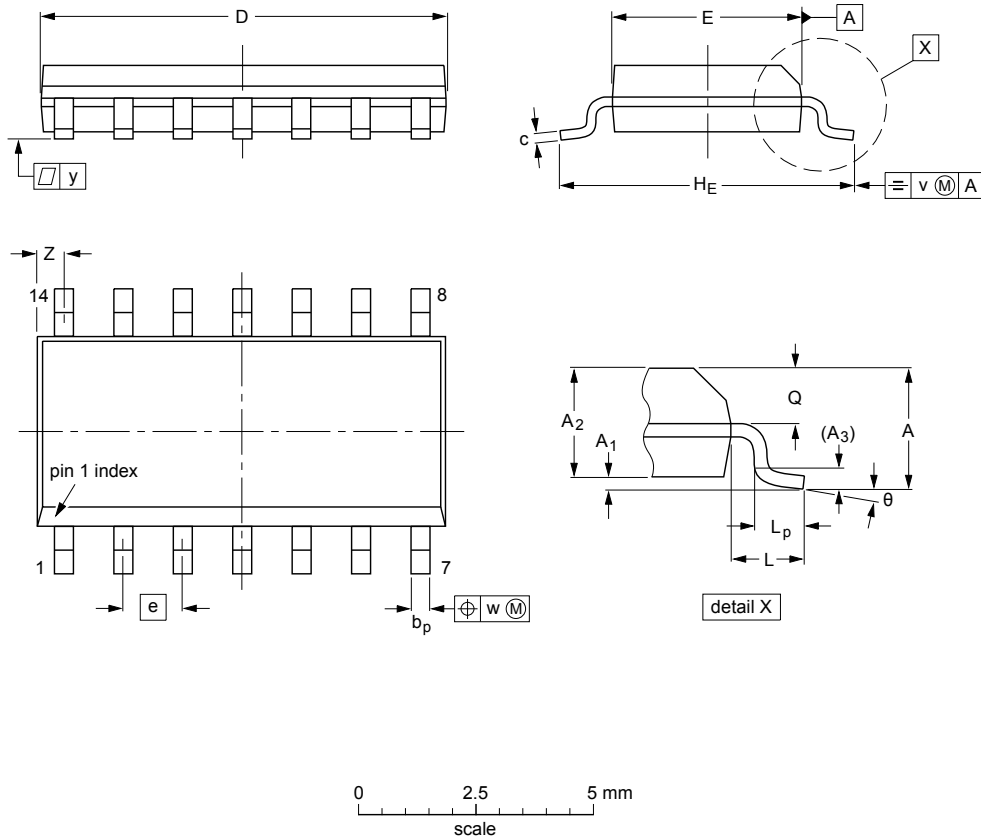

DIMENSIONS (inch dimensions are derived from the original mm dimensions)

UNIT	A max.	A ₁	A ₂	A ₃	b _p	c	D ⁽¹⁾	E ⁽¹⁾	e	H _E	L	L _p	Q	v	w	y	Z ⁽¹⁾	θ
mm	1.75	0.25 0.10	1.45 1.25	0.25	0.49 0.36	0.25 0.19	8.75 8.55	4.0 3.8	1.27	6.2 5.8	1.05	1.0 0.4	0.7 0.6	0.25	0.25	0.1	0.7 0.3	8° 0°
inches	0.069	0.010 0.004	0.057 0.049	0.01	0.019 0.014	0.0100 0.0075	0.35 0.34	0.16 0.15	0.05	0.244 0.228	0.041	0.039 0.016	0.028 0.024	0.01	0.01	0.004	0.028 0.012	

Note

1. Plastic or metal protrusions of 0.15 mm (0.006 inch) maximum per side are not included.

OUTLINE VERSION	REFERENCES			EUROPEAN PROJECTION	ISSUE DATE
	IEC	JEDEC	JEITA		
SOT108-1	076E06	MS-012			99-12-27 03-02-19

Figure 15. Package outline SOT108-1 (SO14)

13 Abbreviations

Table 12. Abbreviations

Acronym	Description
DUT	Device Under Test
ESD	ElectroStatic Discharge
HBM	Human Body Model
MIL	Military
MM	Machine Model

14 Revision history

Table 13. Revision history

Document ID	Release date	Data sheet status	Change notice	Supersedes
HEF4047B_Q100 v.1	20170317	Product data sheet	-	-

15 Legal information

15.1 Data sheet status

Document status ^{[1][2]}	Product status ^[3]	Definition
Objective [short] data sheet	Development	This document contains data from the objective specification for product development.
Preliminary [short] data sheet	Qualification	This document contains data from the preliminary specification.
Product [short] data sheet	Production	This document contains the product specification.

[1] Please consult the most recently issued document before initiating or completing a design.

[2] The term 'short data sheet' is explained in section "Definitions".

[3] The product status of device(s) described in this document may have changed since this document was published and may differ in case of multiple devices. The latest product status information is available on the Internet at URL <http://www.nexperia.com>.

15.2 Definitions

Draft — The document is a draft version only. The content is still under internal review and subject to formal approval, which may result in modifications or additions. Nexperia does not give any representations or warranties as to the accuracy or completeness of information included herein and shall have no liability for the consequences of use of such information.

Short data sheet — A short data sheet is an extract from a full data sheet with the same product type number(s) and title. A short data sheet is intended for quick reference only and should not be relied upon to contain detailed and full information. For detailed and full information see the relevant full data sheet, which is available on request via the local Nexperia sales office. In case of any inconsistency or conflict with the short data sheet, the full data sheet shall prevail.

Product specification — The information and data provided in a Product data sheet shall define the specification of the product as agreed between Nexperia and its customer, unless Nexperia and customer have explicitly agreed otherwise in writing. In no event however, shall an agreement be valid in which the Nexperia product is deemed to offer functions and qualities beyond those described in the Product data sheet.

15.3 Disclaimers

Limited warranty and liability — Information in this document is believed to be accurate and reliable. However, Nexperia does not give any representations or warranties, expressed or implied, as to the accuracy or completeness of such information and shall have no liability for the consequences of use of such information. Nexperia takes no responsibility for the content in this document if provided by an information source outside of Nexperia. In no event shall Nexperia be liable for any indirect, incidental, punitive, special or consequential damages (including - without limitation - lost profits, lost savings, business interruption, costs related to the removal or replacement of any products or rework charges) whether or not such damages are based on tort (including negligence), warranty, breach of contract or any other legal theory. Notwithstanding any damages that customer might incur for any reason whatsoever, Nexperia's aggregate and cumulative liability towards customer for the products described herein shall be limited in accordance with the Terms and conditions of commercial sale of Nexperia.

Right to make changes — Nexperia reserves the right to make changes to information published in this document, including without limitation specifications and product descriptions, at any time and without notice. This document supersedes and replaces all information supplied prior to the publication hereof.

Applications — Applications that are described herein for any of these products are for illustrative purposes only. Nexperia makes no representation

or warranty that such applications will be suitable for the specified use without further testing or modification. Customers are responsible for the design and operation of their applications and products using Nexperia products, and Nexperia accepts no liability for any assistance with applications or customer product design. It is customer's sole responsibility to determine whether the Nexperia product is suitable and fit for the customer's applications and products planned, as well as for the planned application and use of customer's third party customer(s). Customers should provide appropriate design and operating safeguards to minimize the risks associated with their applications and products. Nexperia does not accept any liability related to any default, damage, costs or problem which is based on any weakness or default in the customer's applications or products, or the application or use by customer's third party customer(s). Customer is responsible for doing all necessary testing for the customer's applications and products using Nexperia products in order to avoid a default of the applications and the products or of the application or use by customer's third party customer(s). Nexperia does not accept any liability in this respect.

Limiting values — Stress above one or more limiting values (as defined in the Absolute Maximum Ratings System of IEC 60134) will cause permanent damage to the device. Limiting values are stress ratings only and (proper) operation of the device at these or any other conditions above those given in the Recommended operating conditions section (if present) or the Characteristics sections of this document is not warranted. Constant or repeated exposure to limiting values will permanently and irreversibly affect the quality and reliability of the device.

Terms and conditions of commercial sale — Nexperia products are sold subject to the general terms and conditions of commercial sale, as published at <http://www.nexperia.com/profile/terms>, unless otherwise agreed in a valid written individual agreement. In case an individual agreement is concluded only the terms and conditions of the respective agreement shall apply. Nexperia hereby expressly objects to applying the customer's general terms and conditions with regard to the purchase of Nexperia products by customer.

No offer to sell or license — Nothing in this document may be interpreted or construed as an offer to sell products that is open for acceptance or the grant, conveyance or implication of any license under any copyrights, patents or other industrial or intellectual property rights.

Suitability for use in automotive applications — This Nexperia product has been qualified for use in automotive applications. Unless otherwise agreed in writing, the product is not designed, authorized or warranted to be suitable for use in life support, life-critical or safety-critical systems or equipment, nor in applications where failure or malfunction of an Nexperia product can reasonably be expected to result in personal injury, death or severe property or environmental damage. Nexperia and its suppliers accept no liability for inclusion and/or use of Nexperia products in such equipment or applications and therefore such inclusion and/or use is at the customer's own risk.

Export control — This document as well as the item(s) described herein may be subject to export control regulations. Export might require a prior authorization from competent authorities.

Translations — A non-English (translated) version of a document is for reference only. The English version shall prevail in case of any discrepancy between the translated and English versions.

15.4 Trademarks

Notice: All referenced brands, product names, service names and trademarks are the property of their respective owners.