

HF0402B102R-10

PHYSICAL DIMENSIONS:

A	1.01 [.040]	+	0.18 [.007]
B	0.50 [.020]	+	0.20 [.008]
C	0.50 [.020]	+	0.20 [.008]
D	0.30 [.012]		MAX.

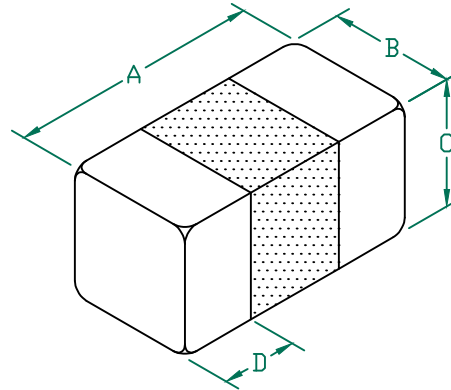

ELECTRICAL CHARACTERISTICS:				
	Z@1000MHz (Ω)	Z@100MHz (Ω)	DCR (Ω)	RATED CURRENT
Nominal	1800	1000	—	—
Minimum	1080	750	—	—
Maximum	2520	1250	1.25	200mA

NOTES: UNLESS OTHERWISE SPECIFIED

1. TAPED AND REELED PER CURRENT EIA SPECIFICATIONS 7" REELS, 10K PCS/REEL, PAPER CARRIER TAPE
2. TERMINATION FINISH IS 100% TIN.
3. COMPONENTS SHOULD BE ADEQUATELY PREHEATED BEFORE SOLDERING.
4. OPERATING TEMPERATURE TEMP: $-40^{\circ}\text{C} \sim +125^{\circ}\text{C}$ (INCLUDING SELF-HEATING)

Z vs FREQUENCY
IMPEDANCE UNDER DC BIAS

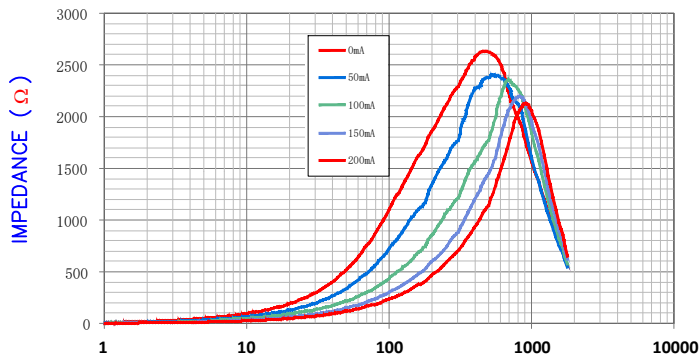

FREQUENCY (MHz)

Z, R, AND X vs. FREQUENCY

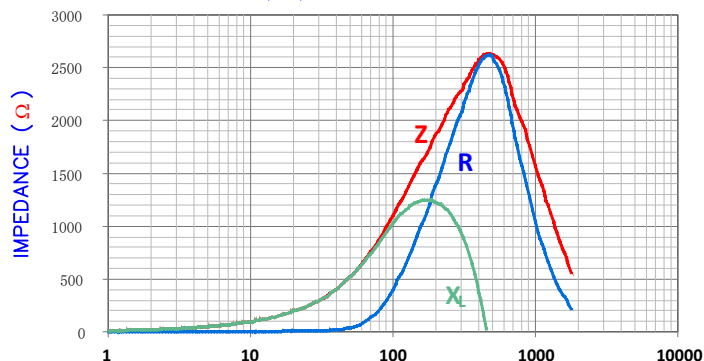

FREQUENCY (MHz)

Z R X_L

LAND PATTERNS FOR REFLOW SOLDERING

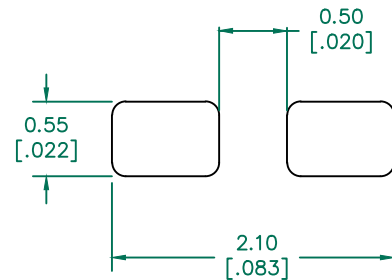

(For wave soldering, add 0.763 (.030 to this dimension.)

RECOMMENDED SOLDERING CONDITIONS

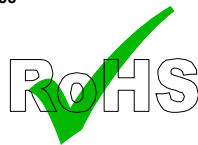
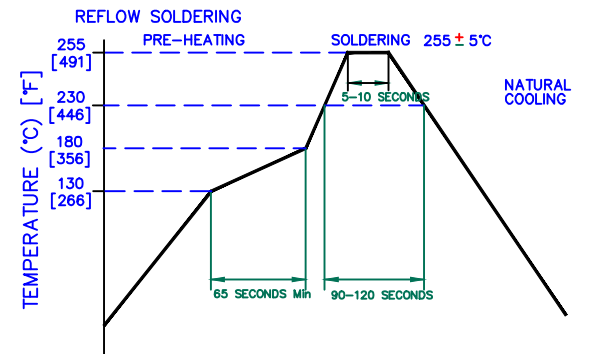

DIMENSIONS ARE IN mm [INCHES].				This print is the property of Laird Tech. and is loaned in confidence subject to return upon request and with the understanding that no copies shall be made without the written consent of Laird Tech. All rights to design or invention are reserved.		Laird	
				PROJECT/PART NUMBER:	HF0402B102R-10	REV	B
				DATE:	06/11/10	PART TYPE:	CO-FIRE
				SCALE:	NTS	DRWN BY:	JUN
B	ADD 1000MHZ IMPEDANCE ADD OPERATING TEMPERATURE	06/20/13	QU	CAD #	HF0402B102R-10-B	TOOL #	-
A	ORIGINAL DRAFT	06/11/10	JUN				
REV	DESCRIPTION	DATE	INT				
						SHEET: 1 of 1	