

HFA3102

Dual Long-Tailed Pair Transistor Array

FN3635  
Rev.5.00  
July 14, 2005

The HFA3102 is an all NPN transistor array configured as dual differential amplifiers with tail transistors. Based on Intersil bonded wafer UHF-1 SOI process, this array achieves very high  $f_T$  (10GHz) while maintaining excellent  $h_{FE}$  and  $V_{BE}$  matching characteristics over temperature. Collector leakage currents are maintained to under 0.01nA.

**Ordering Information**

| PART NUMBER        | TEMP. RANGE (°C) | PACKAGE                            | PKG. DWG. # |
|--------------------|------------------|------------------------------------|-------------|
| HFA3102B96         | -40 to 85        | 14 Ld SOIC Tape and Reel           | M14.15      |
| HFA3102BZ (Note)   | -40 to 85        | 14 Ld SOIC (Pb-free)               | M14.15      |
| HFA3102BZ96 (Note) | -40 to 85        | 14 Ld SOIC Tape and Reel (Pb-free) | M14.15      |

NOTE: Intersil Pb-free plus anneal products employ special Pb-free material sets; molding compounds/die attach materials and 100% matte tin plate termination finish, which are RoHS compliant and compatible with both SnPb and Pb-free soldering operations. Intersil Pb-free products are MSL classified at Pb-free peak reflow temperatures that meet or exceed the Pb-free requirements of IPC/JEDEC J STD-020.

**Pinout/Functional Diagram**

HFA3102 (SOIC)  
TOP VIEW

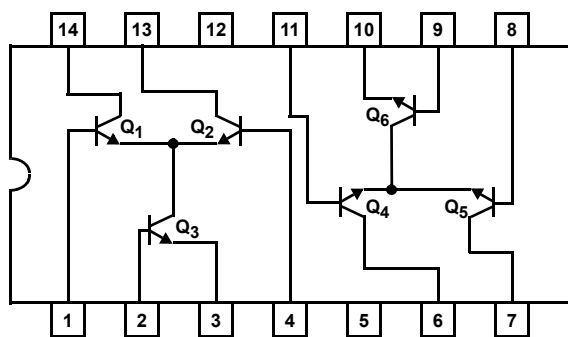

**Features**

- High Gain-Bandwidth Product ( $f_T$ ) . . . . . 10GHz
- High Power Gain-Bandwidth Product. . . . . 5GHz
- High Current Gain ( $h_{FE}$ ) . . . . . 70
- Noise Figure (Transistor) . . . . . 3.5dB
- Low Collector Leakage Current . . . . . <0.01nA
- Excellent  $h_{FE}$  and  $V_{BE}$  Matching
- Pin-to-Pin to UPA102G
- Pb-Free Plus Anneal Available (RoHS Compliant)

**Applications**

- Single Balanced Mixers
- Wide Band Amplification Stages
- Differential Amplifiers
- Multipliers
- Automatic Gain Control Circuits
- Frequency Doublers, Triplers
- Oscillators
- Constant Current Sources
- Wireless Communication Systems
- Radio and Satellite Communications
- Fiber Optic Signal Processing
- High Performance Instrumentation

**Absolute Maximum Ratings**  $T_A = 25^\circ\text{C}$ 

|  |       |
|--|-------|
| $V_{CE0}$ Collector to Emitter Voltage | 8.0V  |
| $V_{CBO}$ Collector to Base Voltage    | 12.0V |
| $V_{EBO}$ Emitter to Base Voltage      | 12.0V |
| $I_C$ , Collector Current              | 30mA  |

**Operating Conditions**

|                   |               |
|-------------------|---------------|
| Temperature Range | -40°C to 85°C |
|-------------------|---------------|

**Thermal Information**

|  |                      |
|--|----------------------|
| Thermal Resistance (Typical, Note 1)           | $\theta_{JA}$ (°C/W) |
| SOIC Package                                   | 128                  |
| Maximum Power Dissipation at 75°               |                      |
| Any One Transistor                             | 0.25W                |
| Maximum Junction Temperature (Die)             | 175°C                |
| Maximum Junction Temperature (Plastic Package) | 150°C                |
| Maximum Storage Temperature Range              | -65°C to 150°C       |
| Maximum Lead Temperature (Soldering 10s)       | 300°C                |
| (SOIC - Lead Tips Only)                        |                      |

**CAUTION:** Stresses above those listed in "Absolute Maximum Ratings" may cause permanent damage to the device. This is a stress only rating and operation of the device at these or any other conditions above those indicated in the operational sections of this specification is not implied.

## NOTE:

- $\theta_{JA}$  is measured with the component mounted on an evaluation PC board in free air.

**Electrical Specifications**  $T_A = 25^\circ\text{C}$ 

| SYMBOLS              | PARAMETER   | TEST CONDITIONS                              | (NOTE 2)<br>TEST<br>LEVEL | ALL GRADES |      |      | UNITS                        |    |
|----------------------|---|--|---------------------------|------------|------|------|------------------------------|----|
|                      |   |  |                           | MIN        | TYP  | MAX  |                              |    |
| $V_{(BR)CBO}$        | Collector-to-Base Breakdown Voltage ( $Q_1$ , $Q_2$ , $Q_4$ , and $Q_5$ ) | $I_C = 100\mu\text{A}$ , $I_E = 0$           | A                         | 12         | 18   | -    | V                            |    |
| $V_{(BR)CEO}$        | Collector-to-Emitter Breakdown Voltage ( $Q_1$ thru $Q_6$ )               | $I_C = 100\mu\text{A}$ , $I_B = 0$           | A                         | 8          | 12   | -    | V                            |    |
| $V_{(BR)EBO}$        | Emitter-to-Base Breakdown Voltage ( $Q_3$ and $Q_6$ )                     | $I_E = 50\mu\text{A}$ , $I_C = 0$            | A                         | 5.5        | 6    | -    | V                            |    |
| $I_{CBO}$            | Collector Cutoff Current ( $Q_1$ , $Q_2$ , $Q_4$ , and $Q_5$ )            | $V_{CB} = 5\text{V}$ , $I_E = 0$             | A                         | -          | 0.1  | 10   | $\mu\text{A}$                |    |
| $I_{EBO}$            | Emitter Cutoff Current ( $Q_3$ and $Q_6$ )                                | $V_{EB} = 1\text{V}$ , $I_C = 0$             | A                         | -          | -    | 100  | $\mu\text{A}$                |    |
| $h_{FE}$             | DC Current Gain ( $Q_1$ thru $Q_6$ )                                      | $I_C = 10\text{mA}$ , $V_{CE} = 3\text{V}$   | A                         | 40         | 70   | -    | -                            |    |
| $C_{CB}$             | Collector-to-Base Capacitance   | $V_{CB} = 5\text{V}$ , $f = 1\text{MHz}$     | B                         | -          | 300  | -    | $\overline{\text{fF}}$       |    |
| $C_{EB}$             | Emitter-to-Base Capacitance   | $V_{EB} = 0$ , $f = 1\text{MHz}$             | B                         | -          | 200  | -    | $\overline{\text{fF}}$       |    |
| $f_T$                | Current Gain-Bandwidth Product  | $I_C = 10\text{mA}$ , $V_{CE} = 5\text{V}$   | C                         | -          | 10   | -    | $\overline{\text{GHz}}$      |    |
| $f_{MAX}$            | Power Gain-Bandwidth Product  | $I_C = 10\text{mA}$ , $V_{CE} = 5\text{V}$   | C                         | -          | 5    | -    | GHz                          |    |
| $G_{NFMIN}$          | Available Gain at Minimum Noise Figure                                    | $I_C = 3\text{mA}$ ,<br>$V_{CE} = 3\text{V}$ | $f = 0.5\text{GHz}$       | C          | -    | 17.5 | -                            | dB |
|                      |   |  | $f = 1.0\text{GHz}$       | C          | -    | 12.4 | -                            | dB |
| $NF_{MIN}$           | Minimum Noise Figure  | $I_C = 3\text{mA}$ ,<br>$V_{CE} = 3\text{V}$ | $f = 0.5\text{GHz}$       | C          | -    | 1.8  | -                            | dB |
|                      |   |  | $f = 1.0\text{GHz}$       | C          | -    | 2.1  | -                            | dB |
| $NF_{50\Omega}$      | 50 $\Omega$ Noise Figure  | $I_C = 3\text{mA}$ ,<br>$V_{CE} = 3\text{V}$ | $f = 0.5\text{GHz}$       | C          | -    | 3.3  | -                            | dB |
|                      |   |  | $f = 1.0\text{GHz}$       | C          | -    | 3.5  | -                            | dB |
| $h_{FE1}/h_{FE2}$    | DC Current Gain Matching ( $Q_1$ and $Q_2$ , $Q_4$ and $Q_5$ )            | $I_C = 10\text{mA}$ , $V_{CE} = 3\text{V}$   | A                         | 0.9        | 1.0  | 1.1  | -                            |    |
| $V_{OS}$             | Input Offset Voltage ( $Q_1$ and $Q_2$ , $Q_4$ and $Q_5$ )                | $I_C = 10\text{mA}$ , $V_{CE} = 3\text{V}$   | A                         | -          | 1.5  | 5    | mV                           |    |
| $I_{OS}$             | Input Offset Current ( $Q_1$ and $Q_2$ , $Q_4$ and $Q_5$ )                | $I_C = 10\text{mA}$ , $V_{CE} = 3\text{V}$   | A                         | -          | 5    | 25   | $\mu\text{A}$                |    |
| $dV_{OS}/dT$         | Input Offset Voltage TC ( $Q_1$ and $Q_2$ , $Q_4$ and $Q_5$ )             | $I_C = 10\text{mA}$ , $V_{CE} = 3\text{V}$   | C                         | -          | 0.5  | -    | $\mu\text{V}/^\circ\text{C}$ |    |
| $I_{TRENCH-LEAKAGE}$ | Collector-to-Collector Leakage (Pin 6, 7, 13, and 14)                     | $\Delta V_{TEST} = 5\text{V}$                | B                         | -          | 0.01 | -    | nA                           |    |

## NOTE:

- Test Level: A. Production Tested; B. Typical or Guaranteed Limit Based on Characterization; C. Design Typical for Information Only

**PSICE Model for a Single Transistor**

.Model NUHFARRY NPN

+ ( IS= 1.840E-16 XTI= 3.000E+00 EG= 1.110E+00  
VAF= 7.200E+01+ VAR= 4.500E+00 BF= 1.036E+02 ISE= 1.686E-19  
NE= 1.400E+00+ IKF= 5.400E-02 XTB= 0.000E+00 BR= 1.000E+01  
ISC= 1.605E-14+ NC= 1.800E+00 IKR= 5.400E-02 RC= 1.140E+01  
CJC= 3.980E-13+ MJC= 2.400E-01 VJC= 9.700E-01 FC= 5.000E-01  
CJE= 2.400E-13+ MJE= 5.100E-01 VJE= 8.690E-01 TR= 4.000E-09  
TF= 10.51E-12+ ITF= 3.500E-02 XTF= 2.300E+00 VTF= 3.500E+00  
PTF= 0.000E+00+ XCJC= 9.000E-01 CJS= 1.689E-13 VJS= 9.982E-01  
MJS= 0.000E+00+ RE= 1.848E+00 RB= 5.007E+01 RBM= 1.974E+00  
KF= 0.000E+00

+ AF= 1.000E+00)

**Common Emitter S-Parameters****V<sub>CE</sub> = 5V and I<sub>C</sub> = 5mA**

| FREQ. (Hz) | S <sub>11</sub> | PHASE(S <sub>11</sub> ) | S <sub>12</sub> | PHASE(S <sub>12</sub> ) | S <sub>21</sub> | PHASE(S <sub>21</sub> ) | S <sub>22</sub> | PHASE(S <sub>22</sub> ) |
|------------|-----------------|-------------------------|-----------------|-------------------------|-----------------|-------------------------|-----------------|-------------------------|
| 1.0E+08    | 0.833079        | -11.7873                | 1.418901E-02    | 78.8805                 | 11.0722         | 168.576                 | 0.976833        | -11.0509                |
| 2.0E+08    | 0.791776        | -22.8290                | 2.695740E-02    | 68.6355                 | 10.5177         | 157.897                 | 0.930993        | -21.3586                |
| 3.0E+08    | 0.734911        | -32.6450                | 3.750029E-02    | 59.5861                 | 9.75379         | 148.443                 | 0.868128        | -30.4451                |
| 4.0E+08    | 0.672811        | -41.0871                | 4.572138E-02    | 51.9018                 | 8.91866         | 140.361                 | 0.799886        | -38.1641                |
| 5.0E+08    | 0.612401        | -48.2370                | 5.194147E-02    | 45.5043                 | 8.10511         | 133.569                 | 0.734033        | -44.5998                |
| 6.0E+08    | 0.557126        | -54.2780                | 5.659943E-02    | 40.2112                 | 7.35944         | 127.882                 | 0.674392        | -49.9370                |
| 7.0E+08    | 0.508133        | -59.4102                | 6.009507E-02    | 35.8226                 | 6.69712         | 123.102                 | 0.622181        | -54.3777                |
| 8.0E+08    | 0.465361        | -63.8123                | 6.274213E-02    | 32.1594                 | 6.11750         | 119.047                 | 0.577269        | -58.1022                |
| 9.0E+08    | 0.428238        | -67.6313                | 6.477134E-02    | 29.0743                 | 5.61303         | 115.571                 | 0.538952        | -61.2587                |
| 1.0E+09    | 0.396034        | -70.9834                | 6.634791E-02    | 26.4506                 | 5.17405         | 112.556                 | 0.506365        | -63.9647                |
| 1.1E+09    | 0.368032        | -73.9591                | 6.758932E-02    | 24.1974                 | 4.79104         | 109.913                 | 0.478663        | -66.3116                |
| 1.2E+09    | 0.343589        | -76.6285                | 6.857937E-02    | 22.2441                 | 4.45546         | 107.570                 | 0.455091        | -68.3702                |
| 1.3E+09    | 0.322155        | -79.0462                | 6.937837E-02    | 20.5358                 | 4.15997         | 105.472                 | 0.435008        | -70.1958                |
| 1.4E+09    | 0.303268        | -81.2548                | 7.003020E-02    | 19.0293                 | 3.89845         | 103.576                 | 0.417872        | -71.8314                |
| 1.5E+09    | 0.286542        | -83.2880                | 7.056718E-02    | 17.6908                 | 3.66577         | 101.849                 | 0.403238        | -73.3108                |
| 1.6E+09    | 0.271660        | -85.1723                | 7.101343E-02    | 16.4930                 | 3.45770         | 100.262                 | 0.390735        | -74.6609                |
| 1.7E+09    | 0.258359        | -86.9292                | 7.138717E-02    | 15.4143                 | 3.27074         | 98.7956                 | 0.380056        | -75.9030                |
| 1.8E+09    | 0.246420        | -88.5759                | 7.170231E-02    | 14.4370                 | 3.10197         | 97.4307                 | 0.370947        | -77.0544                |
| 1.9E+09    | 0.235659        | -90.1265                | 7.196964E-02    | 13.5469                 | 2.94897         | 96.1533                 | 0.363195        | -78.1288                |
| 2.0E+09    | 0.225923        | -91.5925                | 7.219757E-02    | 12.7319                 | 2.80969         | 94.9515                 | 0.356623        | -79.1377                |
| 2.1E+09    | 0.217085        | -92.9836                | 7.239274E-02    | 11.9824                 | 2.68243         | 93.8156                 | 0.351081        | -80.0903                |
| 2.2E+09    | 0.209034        | -94.3076                | 7.256046E-02    | 11.2901                 | 2.56573         | 92.7373                 | 0.346442        | -80.9942                |
| 2.3E+09    | 0.201678        | -95.5713                | 7.270498E-02    | 10.6480                 | 2.45837         | 91.7097                 | 0.342599        | -81.8557                |
| 2.4E+09    | 0.194939        | -96.7803                | 7.282977E-02    | 10.0503                 | 2.35928         | 90.7271                 | 0.339458        | -82.6802                |
| 2.5E+09    | 0.188747        | -97.9395                | 7.293764E-02    | 9.49212                 | 2.26756         | 89.7844                 | 0.336942        | -83.4719                |
| 2.6E+09    | 0.183044        | -99.0530                | 7.303093E-02    | 8.96908                 | 2.18243         | 88.8775                 | 0.334982        | -84.2347                |
| 2.7E+09    | 0.177780        | -100.124                | 7.311157E-02    | 8.47753                 | 2.10322         | 88.0026                 | 0.333518        | -84.9716                |
| 2.8E+09    | 0.172909        | -101.156                | 7.318117E-02    | 8.01430                 | 2.02934         | 87.1565                 | 0.332499        | -85.6853                |
| 2.9E+09    | 0.168394        | -102.152                | 7.324107E-02    | 7.57661                 | 1.96027         | 86.3366                 | 0.331879        | -86.3781                |
| 3.0E+09    | 0.164200        | -103.114                | 7.329243E-02    | 7.16204                 | 1.89556         | 85.5404                 | 0.331620        | -87.0518                |

**V<sub>CE</sub> = 5V and I<sub>C</sub> = 10mA**

| FREQ. (Hz) | S <sub>11</sub> | PHASE(S <sub>11</sub> ) | S <sub>12</sub> | PHASE(S <sub>12</sub> ) | S <sub>21</sub> | PHASE(S <sub>21</sub> ) | S <sub>22</sub> | PHASE(S <sub>22</sub> ) |
|------------|-----------------|-------------------------|-----------------|-------------------------|-----------------|-------------------------|-----------------|-------------------------|
| 1.0E+08    | 0.728106        | -16.4319                | 1.273920E-02    | 75.4177                 | 15.1273         | 165.227                 | 0.959692        | -14.2688                |
| 2.0E+08    | 0.670836        | -31.2669                | 2.342300E-02    | 62.8941                 | 13.9061         | 152.045                 | 0.886232        | -26.9507                |
| 3.0E+08    | 0.600268        | -43.7663                | 3.132521E-02    | 52.5891                 | 12.3970         | 141.185                 | 0.796016        | -37.3172                |
| 4.0E+08    | 0.531768        | -54.0028                | 3.681579E-02    | 44.5019                 | 10.9257         | 132.570                 | 0.708892        | -45.4503                |
| 5.0E+08    | 0.471795        | -62.3880                | 4.057046E-02    | 38.2308                 | 9.62995         | 125.781                 | 0.633146        | -51.7704                |
| 6.0E+08    | 0.421506        | -69.3569                | 4.316292E-02    | 33.3405                 | 8.53559         | 120.378                 | 0.570209        | -56.7206                |
| 7.0E+08    | 0.379961        | -75.2612                | 4.499071E-02    | 29.4764                 | 7.62375         | 116.005                 | 0.518803        | -60.6598                |
| 8.0E+08    | 0.345693        | -80.3608                | 4.631140E-02    | 26.3755                 | 6.86423         | 112.398                 | 0.476987        | -63.8540                |
| 9.0E+08    | 0.317301        | -84.8420                | 4.728948E-02    | 23.8481                 | 6.22797         | 109.365                 | 0.442915        | -66.4948                |
| 1.0E+09    | 0.293608        | -88.8381                | 4.803091E-02    | 21.7581                 | 5.69057         | 106.771                 | 0.415044        | -68.7193                |
| 1.1E+09    | 0.273680        | -92.4452                | 4.860515E-02    | 20.0070                 | 5.23257         | 104.518                 | 0.392146        | -70.6269                |
| 1.2E+09    | 0.256782        | -95.7336                | 4.905871E-02    | 18.5224                 | 4.83873         | 102.532                 | 0.373261        | -72.2899                |
| 1.3E+09    | 0.242344        | -98.7555                | 4.942344E-02    | 17.2505                 | 4.49716         | 100.759                 | 0.357640        | -73.7620                |
| 1.4E+09    | 0.229918        | -101.551                | 4.972158E-02    | 16.1506                 | 4.19854         | 99.1602                 | 0.344698        | -75.0832                |
| 1.5E+09    | 0.219152        | -104.150                | 4.996903E-02    | 15.1915                 | 3.93554         | 97.7028                 | 0.333974        | -76.2840                |
| 1.6E+09    | 0.209767        | -106.577                | 5.017730E-02    | 14.3490                 | 3.70234         | 96.3629                 | 0.325102        | -77.3877                |
| 1.7E+09    | 0.201539        | -108.851                | 5.035491E-02    | 13.6040                 | 3.49428         | 95.1215                 | 0.317789        | -78.4122                |
| 1.8E+09    | 0.194288        | -110.988                | 5.050825E-02    | 12.9411                 | 3.30758         | 93.9633                 | 0.311800        | -79.3715                |
| 1.9E+09    | 0.187867        | -113.001                | 5.064218E-02    | 12.3482                 | 3.13919         | 92.8761                 | 0.306940        | -80.2768                |
| 2.0E+09    | 0.182157        | -114.902                | 5.076045E-02    | 11.8151                 | 2.98658         | 91.8500                 | 0.303051        | -81.1365                |
| 2.1E+09    | 0.177056        | -116.698                | 5.086598E-02    | 11.3338                 | 2.84766         | 90.8766                 | 0.300003        | -81.9578                |
| 2.2E+09    | 0.172484        | -118.399                | 5.096107E-02    | 10.8974                 | 2.72068         | 89.9494                 | 0.297686        | -82.7460                |
| 2.3E+09    | 0.168370        | -120.012                | 5.104755E-02    | 10.5001                 | 2.60420         | 89.0626                 | 0.296007        | -83.5057                |
| 2.4E+09    | 0.164656        | -121.542                | 5.112690E-02    | 10.1373                 | 2.49697         | 88.2115                 | 0.294889        | -84.2405                |
| 2.5E+09    | 0.161293        | -122.996                | 5.120031E-02    | 9.80479                 | 2.39793         | 87.3920                 | 0.294266        | -84.9533                |
| 2.6E+09    | 0.158239        | -124.378                | 5.126876E-02    | 9.49919                 | 2.30619         | 86.6007                 | 0.294081        | -85.6466                |
| 2.7E+09    | 0.155458        | -125.694                | 5.133304E-02    | 9.21750                 | 2.22098         | 85.8348                 | 0.294285        | -86.3223                |
| 2.8E+09    | 0.152919        | -126.947                | 5.139381E-02    | 8.95716                 | 2.14162         | 85.0916                 | 0.294836        | -86.9822                |
| 2.9E+09    | 0.150595        | -128.140                | 5.145164E-02    | 8.71595                 | 2.06753         | 84.3690                 | 0.295696        | -87.6275                |
| 3.0E+09    | 0.148463        | -129.279                | 5.150697E-02    | 8.49194                 | 1.99820         | 83.6651                 | 0.296834        | -88.2595                |

**Typical Performance Curves**

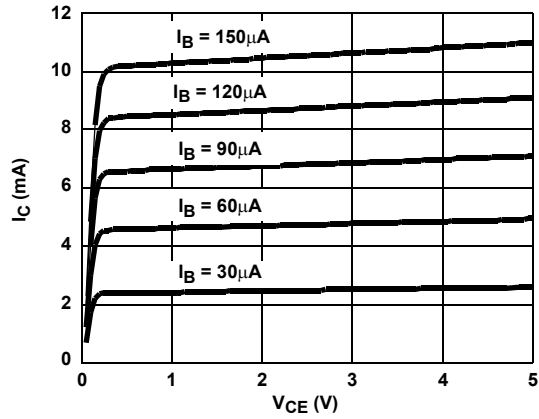

FIGURE 1.  $I_C$  vs  $V_{CE}$

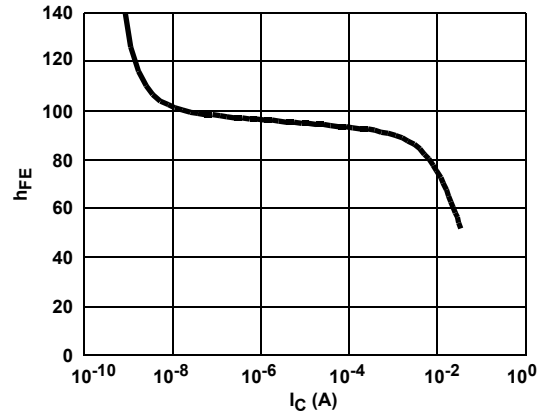

FIGURE 2.  $h_{FE}$  vs  $I_C$

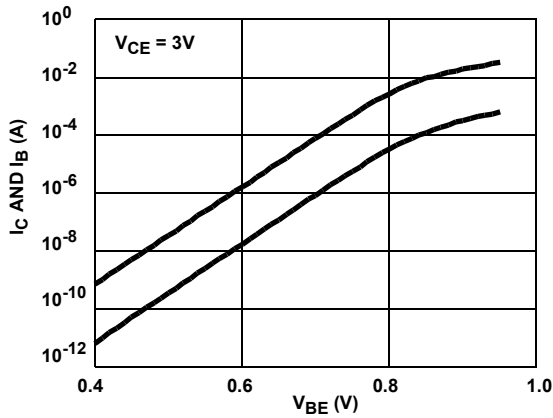

FIGURE 3. GUMMEL PLOT

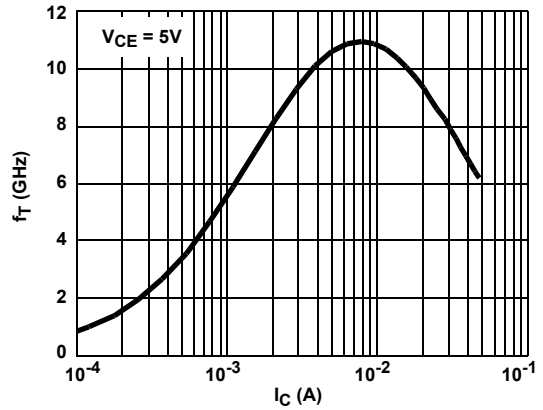

FIGURE 4.  $f_T$  vs  $I_C$

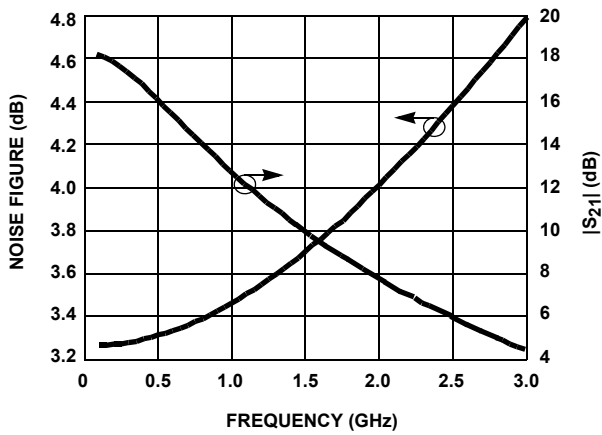

FIGURE 5. GAIN AND NOISE FIGURE vs FREQUENCY

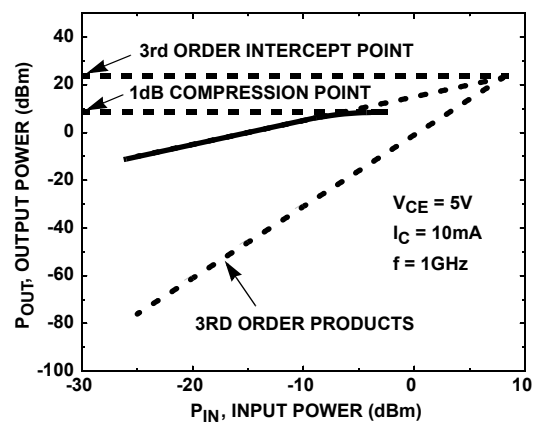

FIGURE 6.  $P_{1dB}$  AND 3RD ORDER INTERCEPT

**Die Characteristics**

**PROCESS:**

UHF-1

**DIE DIMENSIONS:**

53 mils x 52 mils x 14 mils  
 1340µm x 1320µm x 355.6µm

**METALLIZATION:**

Type: Metal 1: AlCu(2%)/TiW  
 Thickness: Metal 1: 8kÅ ±0.5kÅ  
 Type: Metal 2: AlCu(2%)  
 Thickness: Metal 2: 16kÅ ±0.8kÅ

**PASSIVATION:**

Type: Nitride  
 Thickness: 4kÅ ±0.5kÅ

**SUBSTRATE POTENTIAL (POWERED UP):**

Floating

**Metallization Mask Layout**

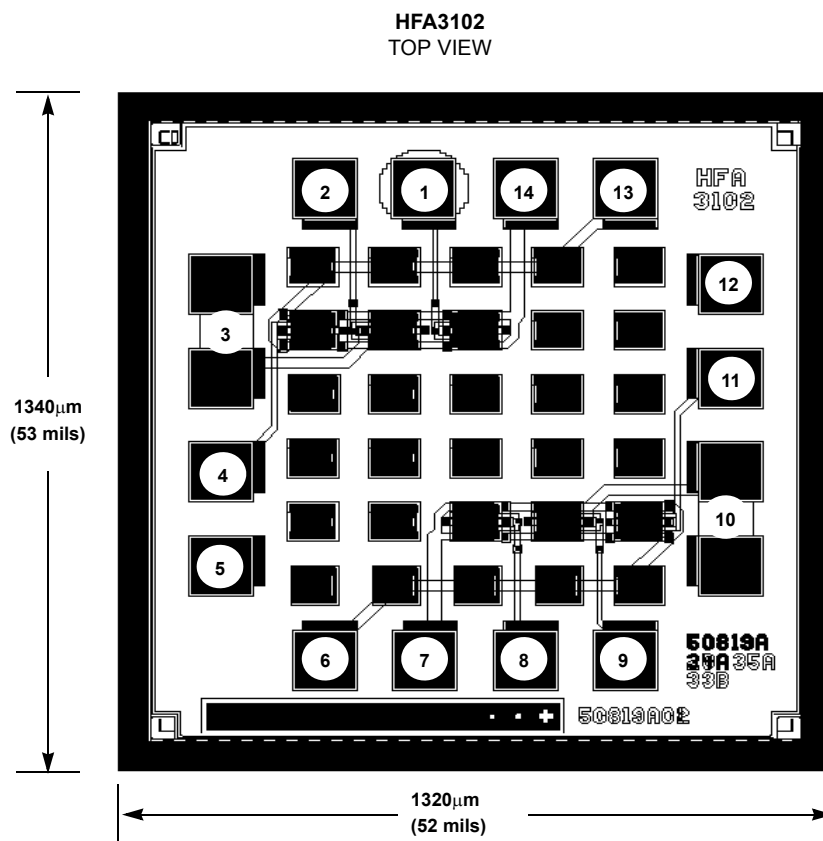

Pad numbers correspond to the 14 pin SOIC pinout.