

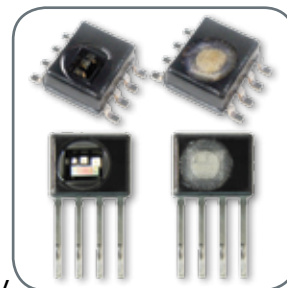

Honeywell HumidIcon™ Digital Humidity/Temperature Sensors

HIH6100 Series

±4.0 %RH Accuracy | ±0.5 °C Temperature Accuracy



Honeywell HumidCon™ Digital Humidity/Temperature Sensors

Honeywell HumidCon™ Digital Humidity/Temperature Sensors, HIH6100 Series, are digital output-type relative humidity (RH) and temperature sensors combined in the same package. These sensors provide an accuracy level of $\pm 4.0\% \text{RH}$ and a temperature accuracy level of $\pm 0.5\text{ }^\circ\text{C}$.

- Industry-leading long-term stability
- Industry-leading Total Error Band
- Industry-leading reliability
- Other accuracies available: $\pm 1.7\% \text{RH}$ (HIH9000 Series), $\pm 2.0\% \text{RH}$ (HIH8000 Series), $\pm 3.0\% \text{RH}$ (HIH7000 Series), and $\pm 4.5\% \text{RH}$ (HIH6000 Series)
- True temperature-compensated digital I²C or SPI output
- Energy efficiency
- Lowest total cost solution
- Ultra-small package size and options

What makes our sensors better?

INDUSTRY-LEADING TOTAL ERROR BAND (TEB) ($\pm 5\% \text{RH}$)*

Honeywell specifies Total Error Band—the most comprehensive, clear, and meaningful measurement —that provides the sensor's true accuracy of $\pm 5\% \text{RH}$ over a compensated range of $5\text{ }^\circ\text{C}$ to $50\text{ }^\circ\text{C}$ [$41\text{ }^\circ\text{F}$ to $122\text{ }^\circ\text{F}$] and $10\% \text{RH}$ to $90\% \text{RH}$. TEB includes all errors due to:

- Humidity non-linearity
- Humidity hysteresis
- Humidity non-repeatability
- Thermal effect on zero
- Thermal effect on span
- Thermal hysteresis



Total Error Band

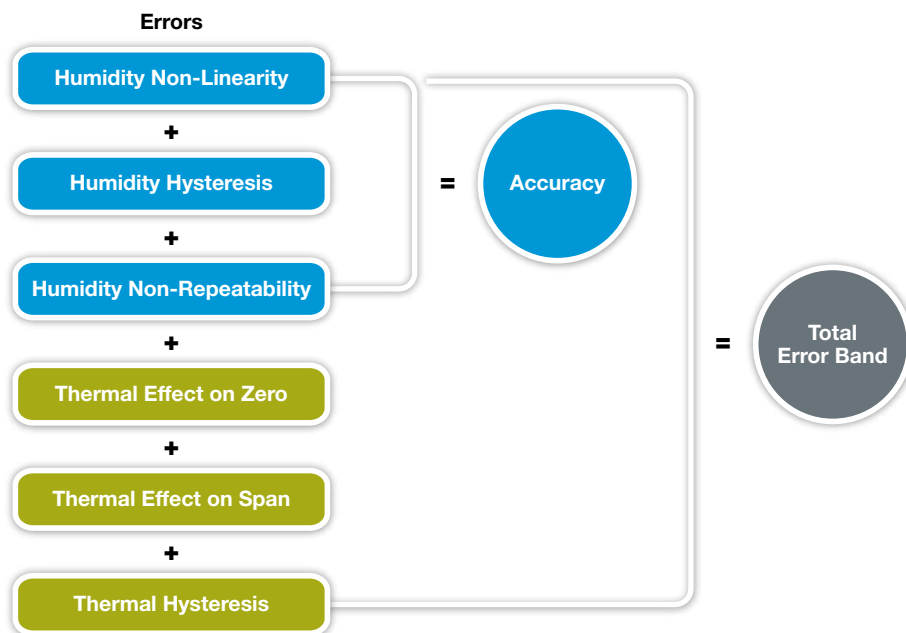

Total Error Band should not be confused with “accuracy”, which is actually a component of Total Error Band. Many competitors simply specify the accuracy of their device; however, the specification may exclude hysteresis and temperature effects, and may be calculated over a very narrow range, at only one point in the range, or at their absolute best accuracy level. It is then up to the customer to calibrate the device to make sure it has the accuracy needed for the life of the application.

Honeywell’s industry-leading Total Error Band provides the following benefits to the customer:

- **Eliminates individually testing** and calibrating every sensor, which can increase their manufacturing time and process.
- Supports system accuracy and warranty requirements.
- Helps to **optimize system uptime**.
- Provides **excellent sensor interchangeability** — the customer can remove one sensor from the tape, then remove the next sensor from the tape, and there is no part-to-part variation in accuracy.

For more information about Total Error Band, please see the related technical note, “Explanation of the Total Error Band Specification for Honeywell’s Digital Humidity/ Temperature Sensors.”

INDUSTRY-LEADING LONG-TERM STABILITY (1.2 %RH OVER FIVE YEARS)*

Competitive humidity sensors need to go through a 12 hour at 75 %RH rehydration process (which requires special equipment chambers) to correct reflow temperature offset. Honeywell’s sensor also experiences an offset after reflow; however, it only requires a five hour rehydration under ambient conditions (>50 %RH). Honeywell’s **industry-leading long term stability** provides the following benefits to the customer.

Honeywell’s industry-leading long-term stability provides the following benefits to the customer:

- Minimizes system performance issues.
- Helps support system uptime by eliminating the need to service or replace the sensor during its application life.
- Eliminates need to regularly recalibrate the sensor in their application, which can be inconvenient and costly.

TRUE, TEMPERATURE-COMPENSATED DIGITAL I²C OR SPI OUTPUT*

This typically allows the customer to remove the components associated with signal conditioning from the PCB to **free up space** and **reduce costs** associated with those components (e.g., acquisition, inventory, assembly). True, temperature-compensated digital I²C or SPI output often eliminates problems that could occur from having multiple signal conditioning components across the PCB, as well as simplifies integration to the microprocessor, eliminating the need for customer-implemented, complex signal conditioning.

*Competitive Differentiator

Features and Benefits

INDUSTRY-LEADING RELIABILITY*

HIH6130/6131 and HIH6120/6121 Series sensors use a laser trimmed, thermoset polymer capacitive sensing element. The element's multilayer construction provides **resistance to most application hazards** such as condensation, dust, dirt, oils, and common environmental chemicals, which helps provide industry-leading stability and reliability.



Offers customers the lowest total cost solution.

LOWEST TOTAL COST SOLUTION*

Honeywell's HumidCon HIH6100 Series offers customers the **lowest total cost solution** due to the sensor's industry-leading Total Error Band and its being a combined humidity/temperature sensor.

One sensor does the work of two!

COMBINED HUMIDITY AND TEMPERATURE SENSOR

The humidity and temperature sensors are co-located in the same package. This allows the RH measurement to be temperature compensated and provides a second, standalone temperature sensor output. This allows the user to **purchase one sensor instead of two.**

ENERGY EFFICIENT*

- **Low supply voltage:** Can operate down to 2.3 Vdc, which allows use in low energy and wireless-compatible applications to enhance energy savings and prolong system battery life.
- **Low power consumption:** The sensor goes into **sleep mode** when not taking a measurement within the application, consuming only 1 μ A of power versus 650 μ A in full operation in a battery operated system. Sleep mode helps maximize battery life, reduces power supply size, and reduces the application's overall weight.

*Competitive Differentiator

Features and Benefits

HIGH RESOLUTION

High 14-bit humidity sensor resolution and 14-bit temperature sensor resolution within the application help the user's system **detect the smallest relative humidity or temperature change**.

Free up PCB space. Reduce costs.

TRUE, TEMPERATURE-COMPENSATED DIGITAL I²C OR SPI OUTPUT*

Typically allows the customer to remove the components associated with signal conditioning from the PCB to **free up space** and **reduce costs** associated with those components (e.g., acquisition, inventory, assembly). Often eliminates problems that could occur from having multiple signal conditioning components across the PCB. Simplifies integration to the microprocessor, eliminating the need for customer-implemented, complex signal conditioning.

Choose options to best fit the application.

ULTRA-SMALL PACKAGE SIZE

SOIC-8 SMD (Surface Mount Device) and SIP 4 Pin packages are ultra small, including the condensation-resistant versions with hydrophobic filter on-board (HIH6121 and HIH6131). Allows for flexibility of use within the application, **occupies less space** on the PCB, and typically simplifies placement on crowded PCBs or in small devices.

FILTER

Available with hydrophobic filter and condensation-resistance, allowing for **use in many condensing environments**, or without hydrophobic filter, non-condensing.

TAPE AND REEL

Cost-effective tape-and-reel packaging allows for use in high volume, automated pick-and-place manufacturing, **eliminating lead misalignment** to the PCB and helping the customer to **reduce manufacturing costs**.

WIDE OPERATING TEMPERATURE RANGE

-25 °C to 85 °C [-13 °F to 185 °F] allows for use in many applications.

OPTIONAL ONE OR TWO %RH LEVEL ALARM OUTPUTS

A feature of the HIH6130 and HIH6131, this provides the ability to monitor whether the RH level has exceeded or fallen below predetermined and critical levels within the application.

MULTI-FUNCTION ASIC

Delivers flexibility within the application by lowering or eliminating the risk and cost of OEM calibration.

ROHS AND WEEE COMPLIANT, HALOGEN FREE

*Competitive Differentiator

Potential Applications



HVAC/R

May be used to provide precision RH and temperature measurement in air conditioning/air movement systems, enthalpy sensing, thermostats, humidifiers/dehumidifiers, and humidistats to maintain occupant comfort and ideal storage humidity/temperature while achieving low energy consumption, supporting system accuracy and warranty requirements, maximizing system uptime, and improving overall system quality.

RESPIRATORY THERAPY

May be used to provide precision RH and temperature measurement in sleep apnea machines and ventilators, enhancing patient comfort, safety and treatment effectiveness with warm and humidified air.



INCUBATORS/MICROENVIRONMENTS

May be used to provide optimal temperature and RH levels to support critical processes and experiments, enhancing process efficiency with desired climate conditions.

AIR COMPRESSORS

May be used to provide precision RH measurement in compressed air lines, allowing the system to remove any condensation; dry compressed air is critical for customer process control measurement.

WEATHER STATIONS

May be used to provide precision RH and temperature measurement in ground-based and airborne weather stations, allowing real time and highly accurate monitoring/reporting of actual weather conditions.



TELECOM CABINETS

May be used to provide precision RH and temperature measurement in the telecom cabinet HVAC system; maintaining proper temperature and humidity levels in the cabinet provides maximum system uptime and performance.

GRAIN DRYING SYSTEMS

May be used in cable-mounted grain drying management systems to measure the moisture content and temperature level inside the grain silos to help the grains remain dry.

Honeywell HumidIcon™ Digital Humidity/Temperature Sensors

Table 1. Environmental Specifications

Characteristic	Condition	Min.	Typ.	Max.	Unit
Operating temperature range	–	-25 [-13]	–	85[185]	°C [°F]
Storage temperature range	–	-40 [-40]	–	85[185]	°C [°F]
Storage humidity	–	30	–	50	%RH
Soldering temperature: automated	IPC/EIA/JEDEC J-STD-020D	–	–	260 [500]	°C [°F]
manual	apply heat for 4 s max. for manual soldering	–	–	350 [662]	
ESD	MIL-STD 883H, Method 3015.7	–	–	±4	kV
Latch-up immunity	–	–	–	±100	mA
Shock	MIL-STD 202G, Method 213D, Test Condition C, half-sine, 6 ms ±3 perpendicular axis, 3 shock pulses per axis	–	–	100	g
Vibration	MIL-STD 202G, Method 204D, Test Condition D, 10 Hz to 2000 Hz	–	–	20	g
Light sensitivity	exposed to 50 lumens yellow light; exhibited no change in output				

Table 2. Humidity Performance Specifications

Characteristic	Condition	Min.	Typ.	Max.	Unit
Supply voltage variation	2.3 Vdc to 5.5 Vdc	–	0.1	0.5	%RH
Compensated humidity range ¹	–	10	–	90	%RH
Compensated temp. range ¹	–	5 [41]	–	50 [122]	°C [°F]
Resolution	14 bit ADC resolution	–	–	0.04	%RH
Accuracy ²	–	–	–	±4	%RH
Total error band ³	–	–	–	±5	%RH
Response time	airflow minimum 20 l/min	–	6	8	s
Operating range	non-condensing	0	–	100	%RH
Long term stability	50 %RH for 5 years	–	±0.05	±1.2	
Impact of soldering	IPC/EIA/JEDEC J-STD-020D, peak temp. of 260 °C [500 °F]	–	–	±2.5	%RH

Notes:

¹ Conversion Formulas:

14 bit ADC output for humidity to %RH:

$$\text{Humidity (\%RH)} = \frac{\text{Humidity_14_bit_ADC_output}}{2^{14} - 2} \times 100$$

14 bit ADC output for temperature conversion to °C:

$$\text{Temperature (C°)} = \frac{\text{Temperature_14_bit_ADC_output}}{2^{14} - 2} \times 165 - 40$$

² Accuracy is specified at the typical supply voltage of 3.3 Vdc and at 25 °C [77 °F]. It is the maximum deviation from the ideal transfer function of relative humidity measured over the humidity range of 10 %RH to 90 %RH and includes all errors due to humidity non-linearity, humidity hysteresis and humidity non-repeatability.

³ Total error band is the maximum deviation from the ideal transfer function of relative humidity over the compensated range of 5 °C [41 °F] to 50 °C [122 °F]. It includes all errors due to humidity non-linearity, humidity hysteresis, humidity non-repeatability, thermal effect on zero, thermal effect on span and thermal hysteresis.

HIH6100 Series ± 4.0 %RH Accuracy | ± 0.5 °C Temperature Accuracy

Table 3. Temperature Performance Specifications

Characteristic	Condition	Min.	Typ.	Max.	Unit
Supply voltage variation	2.3 Vdc to 5.5 Vdc	–	0.5	1.0	°C
Compensated temp. range	–	5 [41]	–	50 [122]	°C [°F]
Resolution	14 bit ADC resolution	–	–	0.025	°C
Accuracy	–	–	± 0.5	–	°C
Response time	1/e slow moving air	5	–	30	s
Long term stability	25 °C for 5 years	–	–	± 0.05	°C/yr
Impact of soldering	IPC/EIA/JEDEC J-STD-020D, peak temp. of 260 °C [500 °F]	–	–	± 0.1	°C

Table 4. Current Consumption

Characteristic	V _{DD}	Abbr.	Condition	Typ.	Max.	Unit
Sleep current	3.3	I _{SLEEP}	–	0.6	1	μA
Supply current:						
I ² C	3.3	I _{DD}	14 bit fastest update, no sleep	0.65	1	mA
SPI	3.3	I _{DD}	14 bit fastest update, no sleep	0.75	1	mA

Table 5. Input and Output Characteristics

Characteristic	Abbr.	Condition	Min.	Typ.	Max.	Unit
Supply voltage	V _{DD}	–	2.3	3.3	5.5	Vdc
Low level output voltage	V _{OL}	I _{OL} = 2.8 mA min.	–	–	20 %	V _{DD}
High level output voltage	V _{OH}	I _{OH} = -2.8 mA min.	80 %	–	–	V _{DD}
Low level input voltage	V _{IL}	–	–	–	20 %	V _{DD}
High level input voltage	V _{IH}	–	80 %	–	–	V _{DD}
Pull-up resistor:						
I ² C	R _P	–	–	2.2	–	kOhm
SPI (for SS only)	R _{SS}	–	–	10	–	kOhm

Table 6. Measurement Timing

Characteristic	Abbr.	Condition	Min.	Typ.	Max.	Unit
Start-up time (power-on to data ready)	T _{STA}	14 bit TH and 14 bit humidity resolution	–	50	60	ms
Update rate	application dependent: measurements are taken only when the application requests them					

Honeywell HumidCon™ Digital Humidity/Temperature Sensors

Figure 1. I²C Timing Diagram

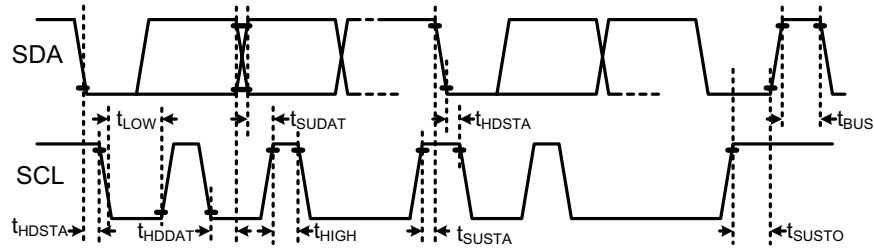

Characteristic	Abbr.	Min.	Typ.	Max.	Unit
SCL clock frequency	F_{SCL}	100	–	400	kHz
Start condition hold time relative to SCL edge	t_{HDSTA}	0.1	–	–	μ s
Minimum SCL clock low width ¹	t_{LOW}	0.6	–	–	μ s
Minimum SCL clock high width ¹	t_{HIGH}	0.6	–	–	μ s
Start condition setup time relative to SCL edge	t_{SUSTA}	0.1	–	–	μ s
Data hold time on SDA relative to SCL edge	t_{HDDAT}	0	–	0.5	μ s
Data setup time on SDA relative to SCL edge	t_{SUDAT}	0.1	–	–	μ s
Stop condition setup time on SCL	t_{SUSTO}	0.1	–	–	μ s
Bus free time between stop and start condition	t_{BUS}	1	–	–	μ s

Note:

¹ Combined low and high widths must equal or exceed minimum SCL period.

Figure 2. SPI Timing Diagram

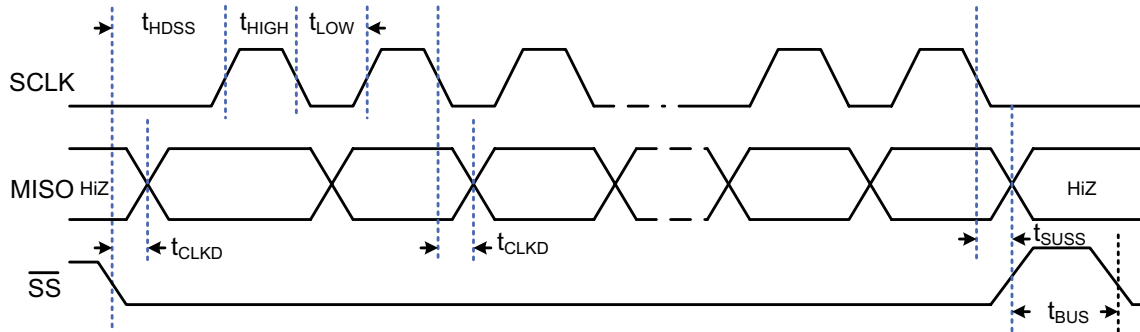

Characteristic	Abbr.	Min.	Typ.	Max.	Unit
SCLK clock frequency	f_{SCL}	50	–	800	kHz
SS drop to first clock edge	t_{HDSS}	2.5	–	–	μ s
Minimum SCLK clock low width ¹	t_{LOW}	0.6	–	–	μ s
Minimum SCLK clock high width ¹	t_{HIGH}	0.6	–	–	μ s
Clock edge to data transition	t_{CLKD}	0	–	0.5	μ s
Rise of SS relative to last clock edge	t_{SUSS}	0.1	–	–	μ s
Bus free time between rise and fall of SS	t_{BUS}	2	–	–	μ s

Note:

¹ Combined low and high widths must equal or exceed minimum SCLK period.

HIH6100 Series ± 4.0 %RH Accuracy | ± 0.5 °C Temperature Accuracy

Table 7. HIH6130/6131 and HIH6120/6121 Series Maximal Accuracy¹
(Performance is specified between 10 %RH and 90 %RH)

90	± 1	± 2	± 2	± 2	± 3	± 3	± 3	± 3	± 3	± 2
	± 1	± 2	± 2	± 2	± 3	± 3	± 3	± 3	± 3	± 2
80	± 1	± 2	± 2	± 2	± 2	± 2	± 2	± 2	± 2	± 1
	± 2	± 2	± 2	± 2	± 2	± 2	± 2	± 2	± 2	± 2
70	± 2	± 3	± 3	± 3	± 2	± 2	± 2	± 2	± 2	± 2
	± 2	± 3	± 3	± 3	± 3	± 3	± 3	± 3	± 3	± 2
60	± 2	± 3	± 3	± 3	± 3	± 3	± 3	± 3	± 3	± 2
	± 2	± 3	± 3	± 3	± 3	± 3	± 3	± 3	± 3	± 2
50	± 2	± 3	± 3	± 3	± 3	± 3	± 3	± 3	± 3	± 2
	± 2	± 3	± 3	± 3	± 3	± 3	± 3	± 3	± 3	± 2
40	± 2	± 3	± 3	± 3	± 3	± 3	± 3	± 3	± 3	± 2
	± 2	± 3	± 3	± 3	± 3	± 3	± 3	± 3	± 3	± 2
30	± 2	± 3	± 3	± 3	± 3	± 3	± 3	± 3	± 3	± 2
	± 2	± 3	± 3	± 3	± 3	± 3	± 3	± 3	± 3	± 2
20	± 1	± 3	± 3	± 3	± 3	± 3	± 3	± 3	± 3	± 1
	± 1	± 3	± 3	± 3	± 3	± 3	± 3	± 3	± 3	± 1
10	± 1	± 3	± 3	± 3	± 3	± 3	± 3	± 3	± 3	± 1
	± 1	± 3	± 3	± 3	± 3	± 3	± 3	± 3	± 3	± 1
0		10	20	30	40	50				

¹Maximal accuracy is the mean value between rising and falling RH points

TEMPERATURE (°C)

Honeywell HumidCon™ Digital Humidity/Temperature Sensors

Figure 3. SOIC-8 SMD Typical Application Circuits

I²C

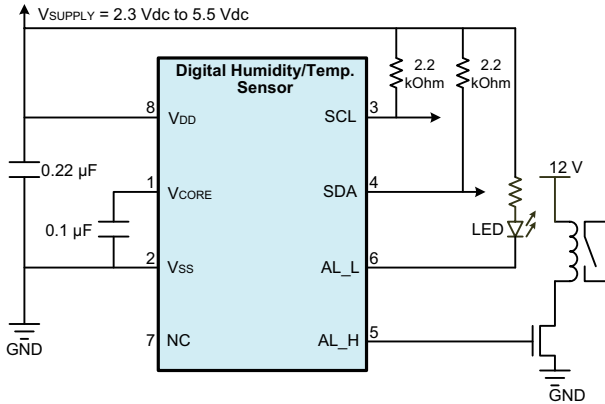

SPI

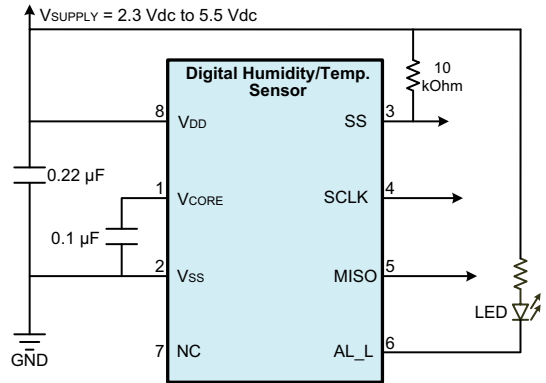
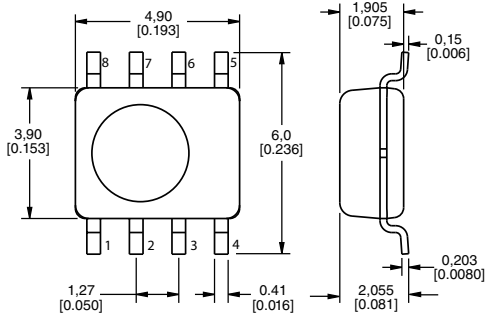
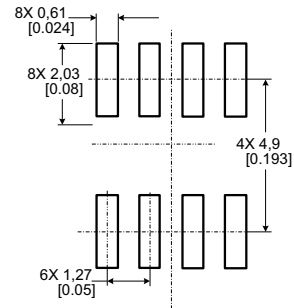

Figure 4. SOIC-8 SMD Mounting Dimensions, PCB Landing Pattern and Pinout [For reference only: mm/[in.]]

Mounting



Landing Pattern



Pinout for I²C Versions

Pin	ASIC Pad	Description
1	V _{CORE}	connect via 0.1 μF to ground
2	V _{SS}	supply ground
3	SCL	I ² C clock
4	SDA	I ² C data
5 ¹	AL_H	alarm output high
6 ¹	AL_L	alarm output low
7	NC	not connected externally
8	V _{DD}	supply voltage, connect via 0.22 μF to ground

¹ Do not connect Pin(s) 5 and/or 6 if the built-in alarm feature is not desired.

Pinout for SPI Versions

Pin	ASIC Pad	Description
1	V _{CORE}	connect via 0.1 μF to ground
2	V _{SS}	supply ground
3	SS	slave select (Input)
4	SCLK	serial clock
5	MISO	master-in-slave-out
6 ¹	AL_L	alarm output low
7	NC	not connected externally
8	V _{DD}	supply voltage, connect via 0.22 μF to ground

¹ Do not connect Pin 6 if the built-in alarm feature is not desired.

Tape and Reel

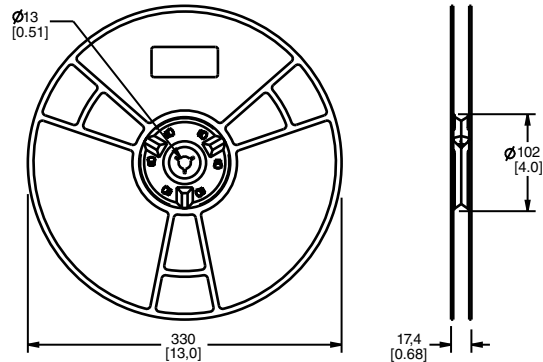
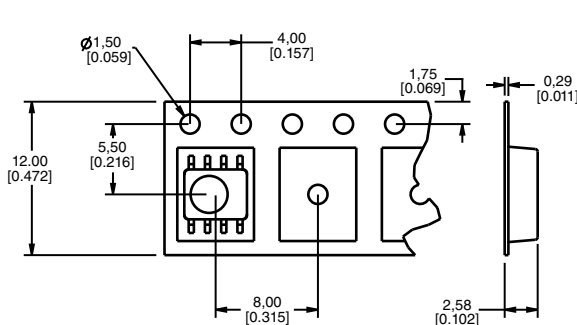

HIH6100 Series $\pm 4.0\%$ RH Accuracy | $\pm 0.5\text{ }^{\circ}\text{C}$ Temperature Accuracy

Figure 5. SIP 4 Pin Typical Application Circuit

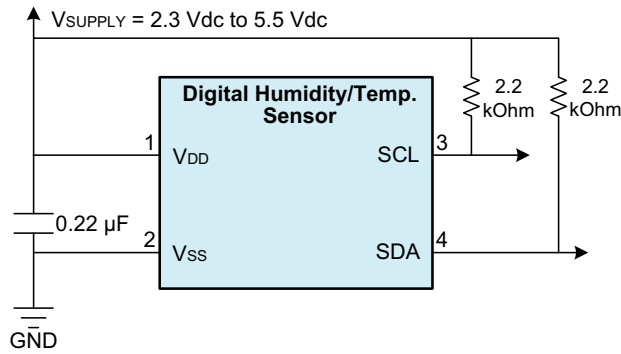
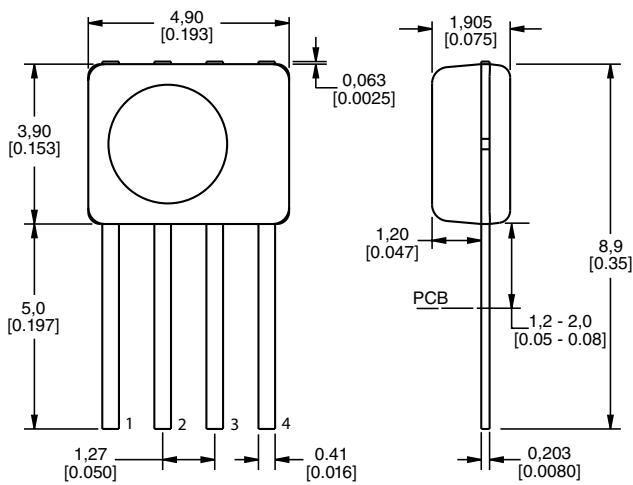
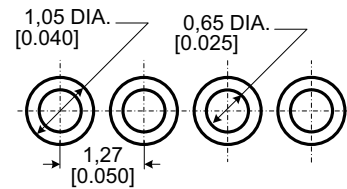

Figure 6. SIP 4 Pin Mounting Dimensions, PCB Landing Pattern and Pinout [For reference only: mm/[in.]

Mounting



Landing Pattern



Pin	ASIC Pad	Description
1	V _{DD}	connect via 0.22 μF to ground
2	V _{SS}	supply ground
3	SCL	I ² C clock
4	SDA	I ² C data

Tape and Reel¹

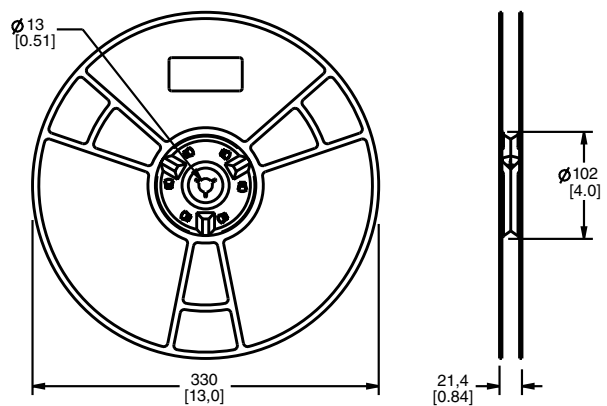
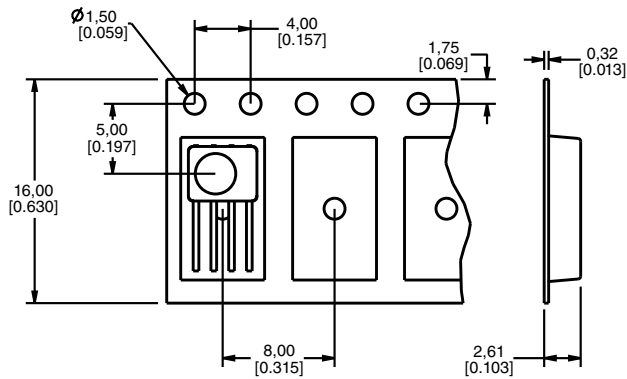

¹ For orders of 250 to 1000 units

Honeywell HumidCon™ Digital Humidity/Temperature Sensors

Product Nomenclature

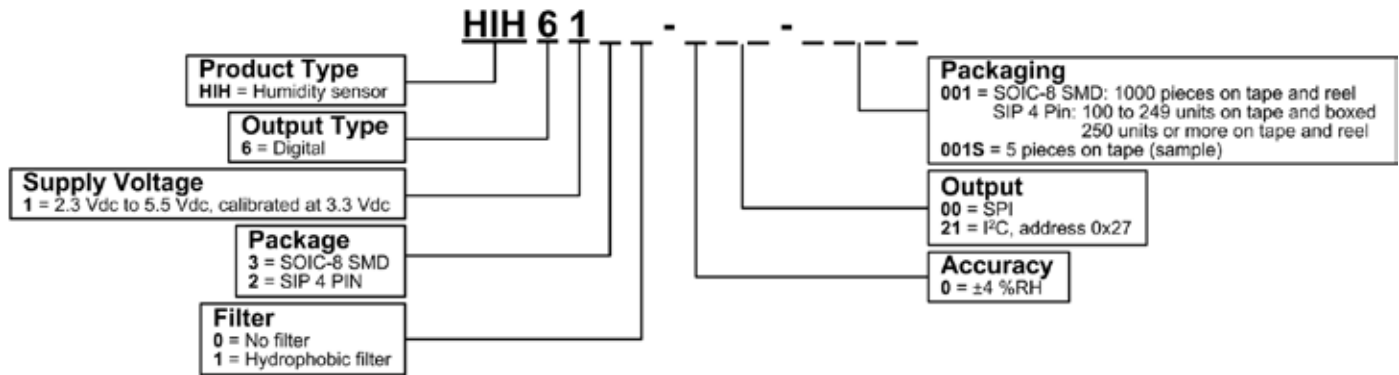

Order Guide

Catalog Listing	Description
HIH6130-000-001	Honeywell HumidCon™ Digital Humidity/Temperature Sensors: HIH6130/6131 Series, SPI, ±5 %RH total error band, SOIC-8 SMD, no filter, non-condensing, 1000 units on tape and reel
HIH6130-000-001S	Honeywell HumidCon™ Digital Humidity/Temperature Sensors: HIH6130/6131 Series, SPI, ±5 %RH total error band, SOIC-8 SMD, no filter, non-condensing, five units on tape (sample)
HIH6131-000-001	Honeywell HumidCon™ Digital Humidity/Temperature Sensors: HIH6130/6131 Series, SPI, ±5 %RH total error band, SOIC-8 SMD, hydrophobic filter, condensation-resistant, 1000 units on tape and reel
HIH6131-000-001S	Honeywell HumidCon™ Digital Humidity/Temperature Sensors: HIH6130/6131 Series, SPI, ±5 %RH total error band, SOIC-8 SMD, hydrophobic filter, condensation-resistant, five units on tape (sample)
HIH6130-021-001	Honeywell HumidCon™ Digital Humidity/Temperature Sensors: HIH6130/6131 Series, I²C, ±5 %RH total error band, SOIC-8 SMD, no filter, non-condensing, 1000 units on tape and reel
HIH6130-021-001S	Honeywell HumidCon™ Digital Humidity/Temperature Sensors: HIH6130/6131 Series, I²C, ±5 %RH total error band, SOIC-8 SMD, no filter, non-condensing, five units on tape (sample)
HIH6131-021-001	Honeywell HumidCon™ Digital Humidity/Temperature Sensors: HIH6130/6131 Series, I²C, ±5 %RH total error band, SOIC-8 SMD, hydrophobic filter, condensation-resistant, 1000 units on tape and reel
HIH6131-021-001S	Honeywell HumidCon™ Digital Humidity/Temperature Sensors: HIH6130/6131 Series, I²C, ±5 %RH total error band, SOIC-8 SMD, hydrophobic filter, condensation-resistant, five units on tape (sample)
HIH6120-021-001 ¹	Honeywell HumidCon™ Digital Humidity/Temperature Sensors: HIH6120/6121 Series, I²C, ±5 %RH total error band, SIP 4 Pin, no filter, non-condensing, 100 units on tape
HIH6120-021-001S	Honeywell HumidCon™ Digital Humidity/Temperature Sensors: HIH6120/6121 Series, I²C, ±5 %RH total error band, SIP 4 Pin, no filter, non-condensing, five units on tape (sample)
HIH6121-021-001 ¹	Honeywell HumidCon™ Digital Humidity/Temperature Sensors: HIH6120/6121 Series, I²C, ±5 %RH total error band, SIP 4 Pin, hydrophobic filter, condensation-resistant, 100 units on tape
HIH6121-021-001S	Honeywell HumidCon™ Digital Humidity/Temperature Sensors: HIH6120/6121 Series, I²C, ±5 %RH total error band, SIP 4 Pin, hydrophobic filter, condensation-resistant, five units on tape (sample)

¹ Orders of 250 units or more are packaged on tape and reel.

HIH6100 Series ± 4.0 %RH Accuracy | ± 0.5 °C Temperature Accuracy

NOTICE: SENSOR REHYDRATION

- Exposure to elevated temperatures, such as those experienced during solder reflow, may dry out the sensing element. It is recommended that the sensor be allowed time to rehydrate after soldering or other high temperature/dry exposures.
- Exposure to these conditions will not permanently damage the sensor. It will generally return to its factory-calibrated value after rehydration.
- If rehydration is not performed, the sensor may read a slight offset that slowly disappears over time as the sensor becomes exposed to ambient conditions. Conversely, extended exposure to condensing and high humidity environments (>90 %RH) may cause a reversible shift in readings which will generally return to normal after the sensor has been allowed to dry off.

To rehydrate the sensor, expose it to room temperature under ambient conditions (>50 %RH) for a minimum of five hours.

WARNING

PERSONAL INJURY

DO NOT USE these products as safety or emergency stop devices or in any other application where failure of the product could result in personal injury.

Failure to comply with these instructions could result in death or serious injury.

WARNING

MISUSE OF DOCUMENTATION

- The information presented in this product sheet is for reference only. Do not use this document as a product installation guide.
- Complete installation, operation, and maintenance information is provided in the instructions supplied with each product.

Failure to comply with these instructions could result in death or serious injury.