

Dec.1.2021 Copyright 2021 HIROSE ELECTRIC CO., LTD. All Rights Reserved.
 In case of consideration for using Automotive equipment / device which demand high reliability, kindly contact our sales window correspondents.

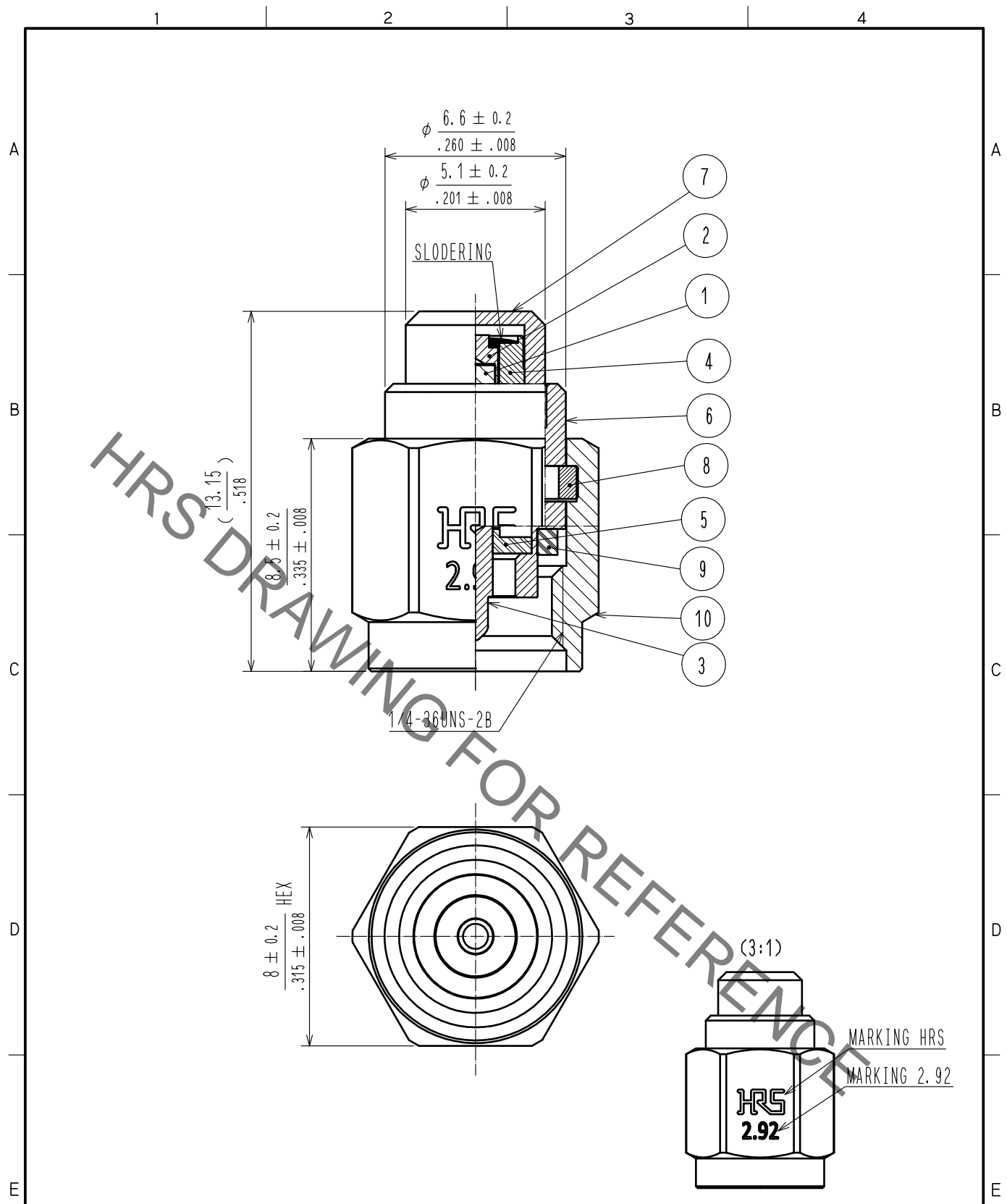

5	PTFE		10	STAINLESS STEEL	PASSIVATE		
4	BRASS	GOLD PLATING	9	SILICONE RUBBER			
3	BRASS	GOLD PLATING	8	BERYLLIUM COPPER	NICKEL PLATING		
2	BRASS	GOLD PLATING	7	BRASS	NICKEL PLATING		
1	RESISTANCE	50Ω	6	STAINLESS STEEL	PASSIVATE		
NO.	MATERIAL	FINISH .	REMARKS	NO.	MATERIAL	FINISH .	REMARKS

UNITS $\frac{1}{1}$ mm / inch		SCALE 5 : 1	COUNT $\frac{1}{1}$	DESCRIPTION OF REVISIONS DIS-D-00006854	DESIGNED MS. MATSUMOTO	CHECKED AH. MARUYAMA	DATE 20210308
HIROSE ELECTRIC CO., LTD.		APPROVED : KH. IKEDA	20170804	DRAWING NO.	EDC-374634-00-00		
		CHECKED : TS. NOBE	20170804	PART NO.	HK-TMP		
		DESIGNED : AH. MARUYAMA	20170804	CODE NO.	CL0353-0014-0-00		
		DRAWN : AH. MARUYAMA	20170804		1/1		