



1.7A Li-ion Battery Switching Charger with Integrated OTG Boost

Features

- ◆ Full Automatic and Efficient Charge Management for Large Capacity Lithium Battery
 - Automatic Conditioning, CC/ CV Charge Control, Termination and Recharge
 - 550-1450mA Programmable Charge Current
 - Support 1.7A Charge Current Using 56mΩ Sensing Resistor
 - 3MHz Synchronous PWM, 1μH Low Profile Inductor
 - Input Current Regulation Accuracy: ±5% (100mA and 500mA)
 - Charge Voltage Regulation Accuracy: -0.25%~0.41%(25°C), ±1%(0°C to 85°C), ±2%(0°C to 125°C)
 - 20V Input Voltage Tolerance, 6.3V Max Operating Voltage
 - Input Voltage Based Dynamic Power Management(VIN DPM)
 - Optional 32s / 30 Minutes Safety Timer with Reset Control
 - Power Up without Battery
- ◆ Automatic Adaptor Fault Detection
- ◆ High Impedance Mode with Low Power Consumption
- ◆ Comprehensive Protection
 - Reverse Battery Leakage Protection
 - Thermal Regulation and Shut-down
 - Input & Output Over-Voltage Protection
- ◆ Built-in Input Current and Input Voltage Limit
- ◆ Integrated Power MOSFET with Max 1.7A Charge Current
- ◆ Automatic Charge and USB Compliant Start Sequence
- ◆ Full Range Programmable Charge Parameter through I²C Compatible Interface
 - Input Current Limit Threshold
 - Input Voltage DPM Threshold
 - Charge Termination Current
 - Charge Termination Voltage
 - Charge Termination Enable
 - Support 3.4MHz I²C HS Mode
- ◆ USB OTG Boost
 - Input Voltage Range from Battery: 2.5V~4.5V
 - 5.0V/ 700mA (V_{BAT} ≥ 3.0V)
- ◆ 1.72mmx1.99mm WLCSP Package

Applications

- Smart phone
- MP3 player
- Tablet PC



Order Information

Part Number	HL7005D	
Default Charge Termination Voltage	4.20V	
Maximum Charge Current	1.7A	
OTG Mode Maximum Output Current	700mA	
I ² C Address	6AH	
Pre-charge Current	500mA	325mA
IC_INFO (Vendor Code)	010	010
IC_INFO (REV)	010	011
30min Safety Timer and 32s Watch-Dog Timer	Yes	
Package	WLCSP	
Packing Method	Tape and Reel	
Marking Information	HL7005DH	HL7005DW

Typical Application Diagram

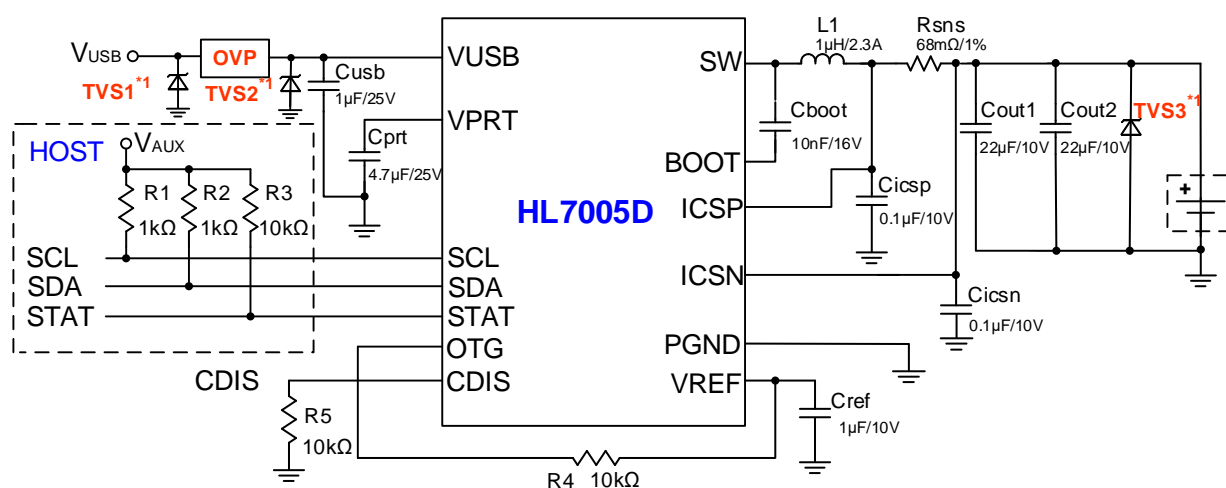

Figure 1. HL7005D Typical Application Diagram

Notice

*1. Careful board level surge protection using TVS diode and OVP device on VIN pin, and TVS diode on VBAT pin, is essential to withstand high voltage spikes that may appear in PCB manufacturing process or end user applications. Without such protection, the IC is prone to electrical over-stress damage.

Component	Part Number	Value	Size	Vendor
L1	LQM2HPN1R0MGH	1μH/2.3A	2016	Murata
Cicsp, Cicsn	C1005X5R1A104K	0.1μF/10V	0402	TDK
Cboot	C2012X5R1E103K	10nF/16V	0805	TDK
Cusb	C2012X5R1E105K	1μF/25V	0805	TDK



Cprt	C2012X5R1E475K	4.7 μ F/25V	0805	TDK
Cref	GRM185R61A105K	1 μ F/10V	0603	Murata
Cout1, Cout2	GRM319R61A226ME15D	22 μ F/10V	1206	Murata
Rsns	ERJ8BWFR068V	68m Ω /1%	1206	PANASONIC
	RL0805FR-070R056L	56m Ω /1%	0805	Yageo
R1,R2	-	1k Ω	-	-
R3,R4,R5	-	10k Ω	-	-
TVS1/TVS2/TVS3	See Table2	-	-	Will SEMI
OVP	See Table3	-	-	Will SEMI

Table 1. Recommended Component list

Component	Package	P _{PK} (W) tp=8/20 μ s	Part Number	V _{RWM} (V)	V _F (V) I _F =20Ma		IR(μ A)	V _{BR} (V)		
				Max	Min	Max	Max	Min	Typ	Max
TVS1	DFN2x2-3L	4000	ESD564 1D12	12.0	0.45	1.25	0.1	13.0	15.0	17.0
TVS2	DFN2x2-3L	4000	ESD564 1D07	7.5	0.45	1.25	1.0	8.0	9.0	10.0
TVS3	DFN2x2-3L	3500	ESD5616 1D04	4.5	0.50	1.10	8.0	5.1	5.7	6.3

Table 2. Recommended TVS

Component	Part Number	VIN(MAX)	RON	Package	Component Dimensions(mm)		
					L	W	H
OVP	WS3210C68	30V	45m Ω	WLCSP-9B	1.400	1.400	0.586

Table 3. Recommended OVP



Description

HL7005D is a compact, flexible, high-efficiency, USB compliant switch-mode charge management device for single cell Li-ion and Li-polymer battery used in a wide range of portable applications. The charge parameters can be programmed through I²C interface. HL7005D integrates a synchronous PWM controller, power MOSFET, input current sensing, high-accuracy current and voltage regulation, and charge termination function into a tiny CSP package.

HL7005D provides a complete automatic three-phase battery charging control: trickle charge, constant-current charge (CC) and constant voltage charge (CV) until the battery reaches the charge termination voltage. The input current is automatically limited to the value set by the host. Charging is terminated based on the battery voltage and a

user selectable minimum current level. A safety timer with reset control provides a safety backup for I²C interface. During normal operation, the IC automatically restarts the charge cycle if the battery voltage falls below an internal threshold and automatically enters sleep mode or high impedance mode when the input supply is not correctly connected. The charge status can be reported to the host through the I²C interface.

During the charging process, the IC monitors its junction temperature (T_J) and reduces the charge current once T_J increases to about 120°C. To support USB OTG device, HL7005D can provide VBUS (5.0V) by boosting the battery voltage.

HL7005D is available in a 20-pin WLCSP package.