



HL7016

3A I²C Controlled USB/Adapter Li-ion Battery Charger with Power Path and 2.1A OTG Boost

Overview

The HL7016 is a fully integrated switch-mode Li-ion battery charger with power MOSFET, power path management, I²C interface and USB On-the-Go (OTG) boost function. It can be used with single cell or multi-cells in parallel Li-ion and Li-polymer batteries in a wide range of cellphones, smartphones, tablets, power banks, and other portable devices. It's switch-mode operation and low-resistance power path maximize charging, discharging, and boost efficiency. It also reduces battery charging time and extends battery life during a discharging phase.

This device supports a wide range of input sources, including standard USB host port, USB charging port, and high-power AC-DC adapter. It supports an input operating voltage from 3.9V to 14V and can power up the system rail without a battery. It can automatically adjust to the maximum power output of the input source via the input dynamic power management control (INDPM).

The HL7016 manages the complete charging cycle of a Li-ion battery autonomously with or without the presence of an I²C host. It detects the battery voltage and automatically charges the battery in four phases: trickle charge, pre-conditioning, constant current, and constant voltage. It automatically terminates charging when the battery is full and re-starts a charging cycle if the battery voltage falls below the recharge threshold. For a short-circuit protected battery, it can reactivate the battery by providing a float voltage to the battery terminal before charging starts. Its I²C interface provides maximum programmability for charging parameters and system-level communication.

When the I²C host is not present, a built-in watchdog timer stops charging after the timer expires to assure safety battery operation.

A built-in low-resistance power path management system enables instant power-up of the system rail when an input source is plugged in, even with a short battery or no battery. With a valid battery, it provides battery assistant mode during charging when the system load exceeds the capacity of the input source.

The USB OTG boost function provides a programmable 4.55-5.5V or 9V boost output at VIN port from the battery and supports current up to 2.1A.

The HL7016 integrates comprehensive protection mechanism to ensure safe operation of the battery, including battery temperature monitoring via negative temperature coefficient (NTC) thermistor, charging safety timer, over-voltage and under-voltage detections. The device also provides output over-current protection and regulates its on-chip junction temperature (T_J_REG) to be no more than 120°C by regulating its charging current.

The HL7016 is available in a 24-pin 4mm x 4mm QFN package.

Features

- 20V input voltage tolerance, 3.9-14V operating voltage range
- High efficiency 3A switch mode charger
 - 92% Charge efficiency at 2A
- USB-compliant/adapter charger
 - USB 1.0/2.0/3.0 compliant input current limit
 - 0.1-3A programmable input current limit
- Autonomous preconditioning, CC/CV charge control, termination, and recharge
- 1.5MHz Synchronous PWM converter for small 1μH inductor
- USB OTG boost programmable VOUT: 4.55-5.5V or 9V
 - Max IOU: 2.5A @ 4.55-5.5V
 - 90% Efficiency at 1.5A
 - Hiccup mode over-current protection for reliable capacitive load start-up
- Power path management
 - Instant system on with no battery or deeply discharged battery
 - Ideal diode operation in battery assistant mode
- Full range programmable charge parameter through I²C compatible interface
- Accuracy (0°-125°C)
 - ±1% Charge voltage regulation
 - ±10% Charge current regulation
 - ±10% Input current regulation
 - ±2% Output regulation in boost mode
- High integration
 - Dynamic power path management
 - Synchronous switch MOSFET
 - Integrated current sensing
 - Bootstrap diode
 - Internal loop compensation
- Comprehensive protections
 - Safety timer with reset control
 - Thermal regulation and shutdown
 - Input & output over-voltage protection
 - Output over-current protection
 - Reverse battery leakage protection
- Charge status output for LED or host processor
- Shipping mode and low battery leakage current
- 4mm x 4mm QFN-24 package

Applications

- Tablet PCs
- Smartphones
- Power Banks
- Portable Media Players

Simplified Application Diagram

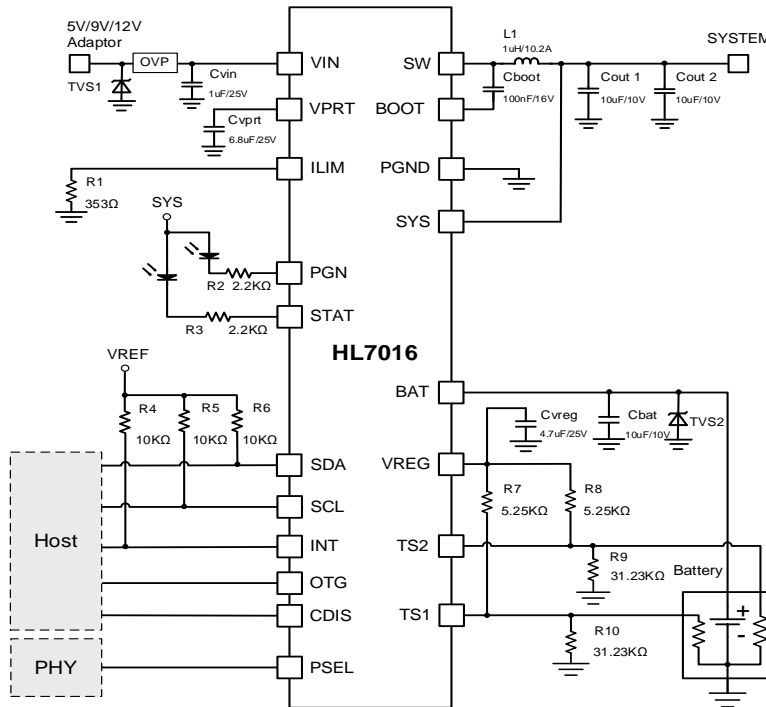

Ordering Information

Part Number	HL7016
I ² C address	6BH
USB detection	PSEL
Default battery voltage	4.208V
Default charge current	2.048A
Max charge current	3A
Max pre-charge current	2.048A
OTG current (Max)	2.1A
Charging temperature profile	Cold/Hot, 2 TS pins
Status output	STAT, PGN
STAT during fault	Blinking@1Hz
Package	4mm x 4mm QFN-24
Packing method	Tape & Reel