



## 4.5A I<sup>2</sup>C Controlled USB/Adaptor Li-ion Battery Charger with Power Path and 2.1A OTG Boost

### Features

- ◆ 20V Input Voltage Tolerance, 3.9V–14V Operating Voltage Range
- ◆ High Efficiency 4.5A Switch Mode Charger
  - 92% Charge Efficiency at 2A
- ◆ USB-compliant/Adapter Charger
  - USB1.0/2.0/3.0 Compliant Input Current Limit
  - 0.1-4.5A Programmable Input Current Limit
- ◆ Autonomous Preconditioning/CC/CV Charge Control, Termination and Recharge
- ◆ 1.5MHz Synchronous PWM Converter for Small 1uH Inductor
- ◆ USB OTG Boost Programmable Vout: 4.55V~5.5V or 9V
  - Max Iout: 2.5A@4.55V-5.5V
  - 90% Efficiency at 1.5A
  - Hiccup Mode Over-Current Protection for Reliable Capacitive Load Start-up
- ◆ Power Path Management
  - Instant System On with No Battery or Deeply Discharged Battery
  - Ideal Diode Operation in Battery assistant Mode
  - System Reset and Battery Disconnect
- ◆ Full Range Programmable Charge Parameter through I<sup>2</sup>C Compatible Interface
- ◆ Accuracy (0°~125°C)
  - ±1% Charge Voltage Regulation
  - ±10% Charge Current Regulation
  - ±10% Input Current Regulation
  - ±2% Output Regulation in Boost Mode
- ◆ High Integration
  - Dynamic Power Path Management
  - Synchronous Switching MOSFET
  - Integrated Current Sensing
  - Bootstrap Diode
  - Internal Loop Compensation
- ◆ Comprehensive Protection
  - Safety Timer with Reset Control
  - Thermal Regulation and Shutdown
  - Input & Output Over-Voltage Protection
  - Output Over Current Protection
  - Reverse Battery Leakage Protection
- ◆ Charge Status Output for LED or Host Processor
- ◆ Shipping Mode and Low Battery Leakage Current
- ◆ 4mm X 4mm QFN-24 Package

### Applications

- ◆ Tablet PC
- ◆ Smart Phone
- ◆ Power Bank
- ◆ Portable Media Player



## Order Information

Part Number	HL7018
I <sup>2</sup> C Address	6BH
USB Detection	PSEL
Default Battery Voltage	4.208V
Default Charge Current	2.048A
Max Charge Current	4.5A
Max Pre-charge Current	2.048A
OTG Current (Max)	2.1A
Charging Temperature Profile	Cold/Hot, 1 TS pin
Status Output	STAT
STAT during Fault	Blinking@1Hz
Package	4mm X 4mm QFN-24
Packing Method	Tape & Reel



## Typical Application Diagram

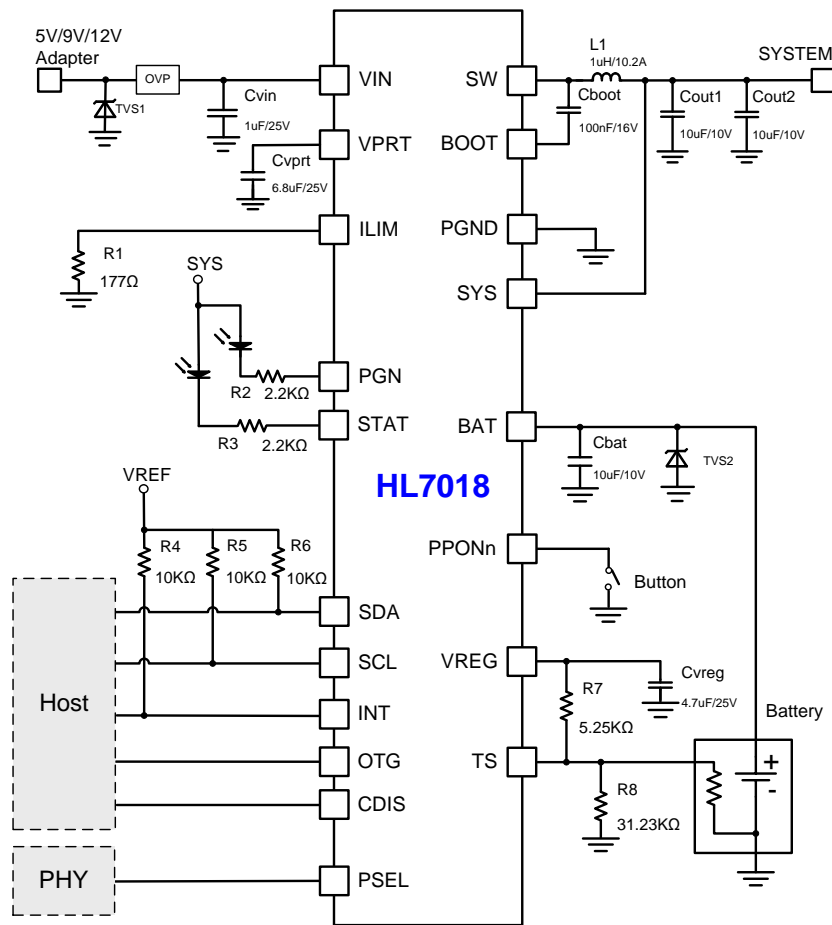

Figure 1 HL7018 Typical Application Diagram

Component	Part Number	Value	Size	Vendor
L1	IHLP2020ABER1R0M01	1μH/10.2A	-	VISHAY
Cvin	CGA5L2X7R1E105K160AD	1μF/25V	1206	TDK
Cvprt	C3225X5R1E685K	6.8μF/25V	1210	TDK
Cboot	C0603X5R1C104K	100nF/16V	0603	TDK
Cvreg	C1206C475K3PACTU	4.7μF/25V	1206	KEMET
Cbat,Cout1,Cout2	C0805C106K8PACTU	10μF/10V	0805	KEMET
R1	-	177Ω	-	-
R2,R3	-	2.2kΩ	-	-
R4,R5,R6	-	10kΩ	-	-
R7	-	5.25kΩ	-	-
R8	-	31.23kΩ	-	-
TVS1/TVS2	See Table2	-	-	Will SEMI
OVP	See Table3	-	-	Will SEMI



Table 1 Recommended Component list

Component	Package	P <sub>PK</sub> (W) tp=8/20 μs	Part Number	VRWM (V)	VF(V) IF=20Ma		IR(μA)	VBR (V)		
				Max	Min	Max	Max	Min	Typ	Max
TVS1	SOD-123F L	5000	ESD562 31L24	±24V	-	-	1	24.4	-	-
TVS2	DFN2x2-3L	3500	ESD5616 1D04	4.5	0.50	1.10	8.0	5.1	5.7	6.3

Table 2 Recommended TVS

Component	Part Number	VIN(MAX)	RON	Package	Component Dimensions(mm)		
					L	W	H
OVP	WS3221	29V	28mΩ	CSP-6L	1.250	0.770	0.570

Table 3 Recommended OVP



## Description

HL7018 is a fully integrated switch-mode Li-ion battery charger with power MOSFET, power path management, I<sup>2</sup>C interface and USB On-The-Go (OTG) boost function. It can be used with single cell or multiple-cell in parallel Li-ion and Li-polymer batteries in a wide range of cell-phones, smart phones, tablets, power banks and other portable devices. Its switch-mode operation and low-resistance power path maximize charging, discharging and boost efficiency, reduce battery charging time and extend battery life during the discharging phase.

This device supports a wide range of input sources, including standard USB host port, USB charging port and high power AC-DC adapter. It supports an input operating voltage from 3.9V to 14V, and can power up the system rail without a battery. It can automatically adjust to the maximum power output of the input source via the input dynamic power management control (INDPM).

HL7018 manages the complete charging cycle of a Li-ion battery autonomously with or without the presence of an I<sup>2</sup>C host. It detects the battery voltage and automatically charges the battery in four phases: trickle charge, pre-conditioning, constant current and constant voltage. It automatically terminates charging when the battery is full, and re-starts a charging cycle if the battery voltage falls below the recharge threshold. For a short-circuit protected battery, it can reactivate the battery by providing a float voltage to the battery terminal before charging starts. Its I<sup>2</sup>C interface provides maximum programmability for

charging parameters and system-level communication. When the I<sup>2</sup>C host is not present, a built-in watchdog timer stops charging after the timer expires to assure safety battery operation.

A built-in low-resistance power path management system enables instant power-up of the system rail when an input source is plugged in, even with a shorted battery or no battery. When a valid battery is present, it provides battery assistant mode during charging when the system load exceeds the capacity of the input source. The power path management system also provides a system reset function by disconnecting the battery and pulling system rail to ground for a programmable amount of time.

The USB OTG boost function provides a programmable 4.55V~5.5V or 9V boost output at VIN port from the battery, and supports up to 2.1A of current.

HL7018 integrates comprehensive protections mechanism to ensure safe operation of the battery, including battery temperature monitoring via negative temperature coefficient (NTC) thermistor, charging safety timer, over-voltage and under-voltage detection. The device also provides output over-current protection, and regulates its on-chip junction temperature ( $T_{J\_REG}$ ) to be no more than 120°C by regulating its charging current.

HL7018 is available in a 24-pin 4mm x 4mm QFN package.