



## 3A I<sup>2</sup>C Controlled USB/Adapter Li-ion Battery Charger with Power Path and 2.1A OTG Boost

### Features

- ◆ 20V Input Voltage Tolerance, 3.9V–7V Operating Voltage Range
- ◆ High Efficiency 3A Switch Mode Charger
- ◆ USB-Compliant/Adapter Charger
  - USB1.0/2.0/3.0 Compliant Input Current Limit
  - 0.1-3A Programmable Input Current Limit
- ◆ Autonomous Preconditioning/CC/CV Charge Control, Termination and Recharge
- ◆ 1.5MHz Synchronous PWM Converter for Small 1uH Inductor
- ◆ USB OTG Boost Programmable Vout: 4.55 V - 5.51 V
  - Max Iout: 2.1A@4.55-5.51V
  - 90% Efficiency at 1.5A
  - Hiccup Mode Over-Current Protection for Reliable Capacitive Load Start-up
- ◆ Power Path Management
  - Instant System On with No Battery or Deeply Discharged Battery
  - Ideal Diode Operation in Battery Assistant Mode
- ◆ Full Range Programmable Charge Parameter through I<sup>2</sup>C Compatible Interface
- ◆ Accuracy (0°~125°C)
  - ±1% Charge Voltage Regulation
  - ±10% Charge Current Regulation
  - ±15% Input Current Regulation
  - ±2% Output Regulation in Boost Mode
- ◆ High Integration
  - Dynamic Power Path Management
  - Synchronous Switching MOSFET
  - Integrated Current Sensing
  - Bootstrap Diode
- Internal Loop Compensation
- ◆ Comprehensive Protection
  - Safety Timer with Reset Control
  - Thermal Regulation and Shutdown
  - Input & Output Over-Voltage Protection
  - Output Over Current Protection
  - Reverse Battery Leakage Protection
- ◆ Charge Status Output for LED or Host Processor
- ◆ Shipping Mode and Low Battery Leakage Current
- ◆ 4mm X 4mm QFN-24 Package

### Applications

- ◆ Tablet PC
- ◆ Smart Phone
- ◆ Power Bank
- ◆ Portable Media Player



## Order Information

Part Number	HL7026
I <sup>2</sup> C Address	6BH
USB Detection	PSEL
Default Battery Voltage	4.208V
Default Charge Current	2.048A
Max Charge Current	3A
Max Pre-charge Current	2.048A
OTG Current (Max)	2.1A
Charging Temperature Profile	Cold/Hot, 1TS pin
Status Output	STAT, PGN
STAT during Fault	Blinking@1Hz
Package	4mm X 4mm QFN-24
Packing Method	Tape & Reel
Package Qty	3000



## Typical Application Diagram

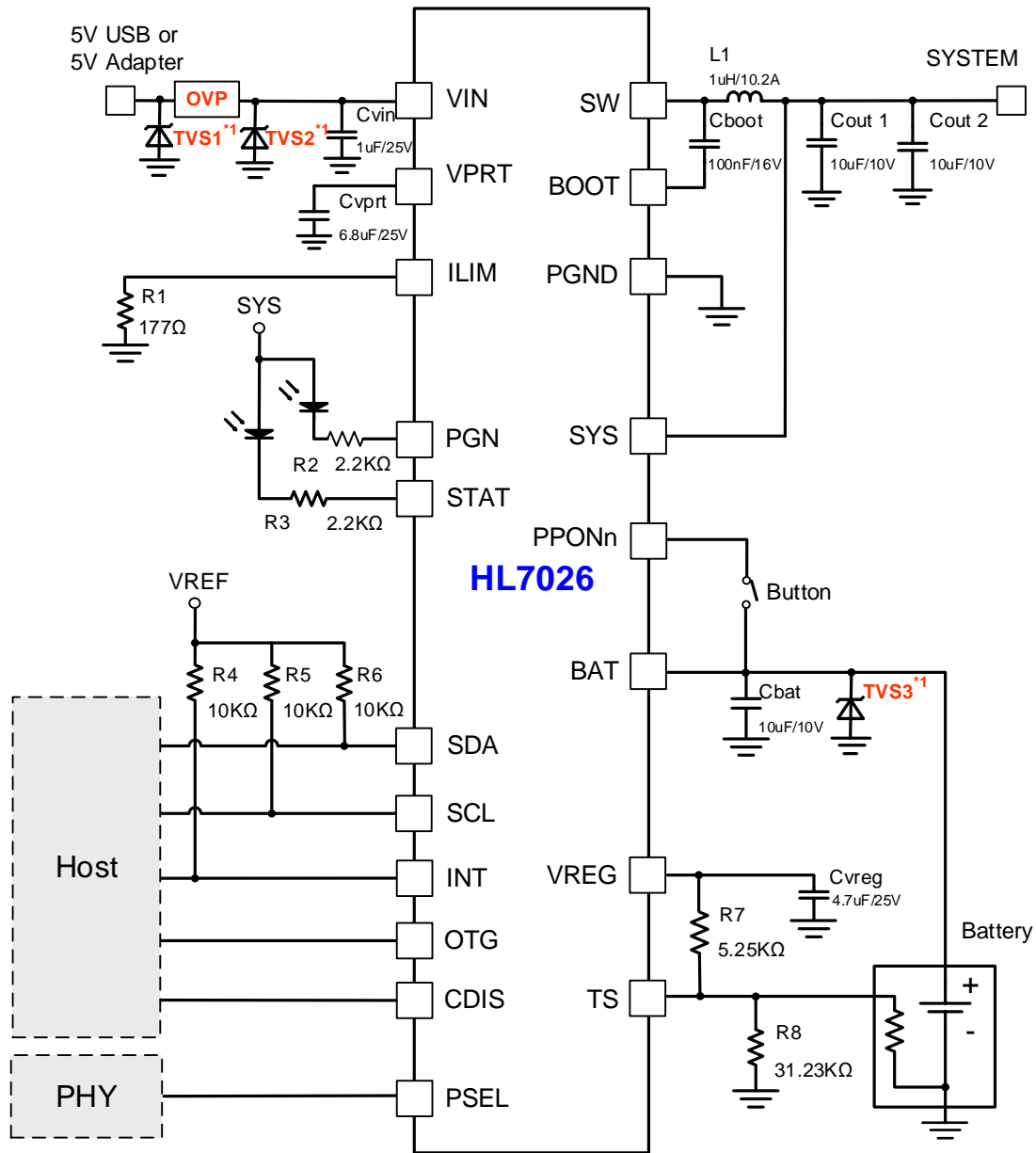

Figure 1 HL7026 Typical Application Diagram

### Notice

\*1. Careful board level surge protection using TVS diode and OVP device on VIN pin, and TVS diode on VBAT pin, is essential to withstand high voltage spikes that may appear in PCB manufacturing process or end user applications. Without such protection, the IC is prone to electrical over-stress damage.

Component	Part Number	Value	Size	Vendor
L1	IHLP2020ABER1R0M01	1μH/10.2A	-	VISHAY
Cvin	CGA5L2X7R1E105K160AD	1μF/25V	1206	TDK
Cvppt	C3225X5R1E685K	6.8μF/25V	1210	TDK



Cboot	C0603X5R1C104K	100nF/16V	0603	TDK
Cvreg	C1206C475K3PACTU	4.7μF/25V	1206	KEMET
Cbat,Cout1,Cout2	C0805C106K8PACTU	10μF/10V	0805	KEMET
R1	-	177Ω	-	-
R2, R3	-	2.2kΩ	-	-
R4,R5,R6	-	10kΩ	-	-
R7	-	5.25kΩ	-	-
R8	-	31.23kΩ	-	-
TVS1/TVS2	See Table2	-	-	Will SEMI
OVP	See Table3	-	-	Will SEMI

Table 1 Recommended Component list

Component	Package	P <sub>PK</sub> (W) tp=8/20 μs	Part Number	V <sub>RWM</sub> (V)	V <sub>F</sub> (V) I <sub>F</sub> =20Ma		I <sub>R</sub> (μA) Max	V <sub>BR</sub> (V)		
				Max	Min	Max		Min	Typ	Max
TVS1	DFN2x2-3L	4000	ESD564 1D12	12.0	0.45	1.25	0.1	13.0	15.0	17.0
TVS2	DFN2x2-3L	4000	ESD564 1D07	7.5	0.45	1.25	1.0	8.0	9.0	10.0
TVS3	DFN2x2-3L	3500	ESD5616 1D04	4.5	0.50	1.10	8.0	5.1	5.7	6.3

Table 2 Recommended TVS

Component	Part Number	V <sub>IN</sub> (MAX)	R <sub>ON</sub>	Package	Component Dimensions(mm)		
					L	W	H
OVP	WS3210C68	30V	45mΩ	WLCSP-9B	1.400	1.400	0.586

Table 3 Recommended OVP



## Description

HL7026 is a fully integrated switch-mode Li-ion battery charger with power MOSFET, power path management, I<sup>2</sup>C interface and USB On-The-Go (OTG) boost function. It can be used with single cell or multiple-cell in parallel Li-ion and Li-polymer batteries in a wide range of smart phones, tablets, power banks and other portable devices. Its switch-mode operation and low-resistance power path maximize charging, discharging and boost efficiency, reduce battery charging time and extend battery life during the discharging phase.

This device supports a wide range of input sources, including standard USB host port, USB charging port and high power AC-DC adapter. It supports an input operating voltage from 3.9V to 7V, and can power up the system rail without a battery. It can automatically adjust to the maximum power output of the input source via the input dynamic power management control (INDPM).

HL7026 manages the complete charging cycle of a Li-ion battery autonomously with or without the presence of an I<sup>2</sup>C host. It detects the battery voltage and automatically charges the battery in four phases: trickle charge, pre-conditioning, constant current and constant voltage. It automatically terminates charging when the battery is full, and restarts a charging cycle if the battery voltage falls below the recharge threshold. For a short circuit protected battery, it can reactivate the battery by providing a float voltage to the battery terminal before charging starts. Its I<sup>2</sup>C interface provides maximum programmability for charging parameters and system level communication. When the I<sup>2</sup>C host is not present, a built in watchdog timer stops charging after the timer expires to assure safety battery operation.

A built in low-resistance power path management system enables instant power-up of the system rail when an input

source is plugged in, even with a shorted battery or no battery. When a valid battery is present, it provides battery assistant mode during charging when the system load exceeds the capacity of the input source.

The USB OTG boost function provides a programmable 4.55V~5.51V boost output at VIN port from the battery, and supports current up to 2.1A.

HL7026 integrates comprehensive protections mechanism to ensure safe operation of the battery, including battery temperature monitoring via negative temperature coefficient (NTC) thermistor, charging safety timer, over-voltage and under-voltage detection. The device also provides output over-current protection, and regulates its on-chip junction temperature ( $T_{J\_REG}$ ) to be no more than 120°C by regulating its charging current.

HL7026 is available in a 24-pin 4mm x 4mm QFN package.