



I²C Programmable 6A DVS Buck Converter

Features

- Input Voltage Range: 2.5V~5.5V
- Programmable Output Voltage:
 - 0.600V to 1.420V in 10 mV, 12.5mV, 12.826mV or 12.967mV steps
- Maximum Output Current:
 - 6A Continuous, 7.5A Peak
- 2.4 MHz PWM with Seamless PWM/PFM Switching for Light-Load Efficiency
- Dynamic Voltage Scaling (DVS) with Programmable Voltage Slew Rate
- Excellent Load and Line Transient
- Quiescent Current in PFM Tristate: 60μA
- I²C Interface with SM, FM, FM⁺ and HS Modes
- Comprehensive Protection
 - Input Under-Voltage Lockout (UVLO)
 - Input Over-Voltage Protection (OVP)
 - Over Current and Short-Circuit Protection
 - Thermal Shutdown
- 2.0mm x 1.6mm 20-Bump Chip-Scale Package

Applications

- Application Processors
- Graphics Processors
- Memory, Hard Disk Drive and SSD
- Smart Phones
- Tablets
- Handheld Devices



Order Information

Part Number	Default V _{OUT} after POR		Max Output Current (RMS)	Max Pulse Current (50ms)	A1 Pin Func.	I ² C Address	V _{OUT} Range	V _{OUT} Step	Package	Packing Method
	VSEL=0	VSEL=1								
HL7501W8	1.020V	1.150V	4A	N/A	VSEL	1100000	0.600V ~ 1.230V	10mV	WLCSP	Tape & Reel
HL7501W9	1.000V	1.000V	5A	N/A	VSEL	1000000	0.603V ~ 1.411V	12.826mV		
HL7501WA	1.000V	1.000V	5A	N/A	VSEL	1000001	0.603V ~ 1.411V	12.826mV		
HL7501WE ¹	1.150V	1.150V	5A	7.0A	VSEL	1100000	0.600V ~ 1.3875V	12.5mV		
HL7501WM	1.000V	1.000V	6A	7.5A	VSEL	1000001	0.600V ~ 1.3875V	12.5mV		
HL7501WN	1.150V	1.150V	5A	7.0A	VSEL	1100000	0.600V ~ 1.3875V	12.5mV		
HL7501WP	OFF	1.150V	5A	N/A	VSEL	1100000	0.600V ~ 1.3875V	12.5mV		
HL7501WS	1.020V	1.150V	5A	N/A	VSEL	1100000	0.600V ~ 1.230V	10mV		
HL7501WT ¹	1.10V	1.20V	5A	N/A	VSEL	1100000	0.603V ~ 1.411V	12.826mV		
HL7501WB	1.10V	1.20V	5A	N/A	VSEL	1100000	0.600V ~ 1.230V	10mV		

Note:

(1) For HL7501WE, HL7501WT, EN pin=0 also resets the chip.

(2) For other default output voltage, mode and I²C address options, contact a Halo Micro sales representative.



Typical Application Diagram

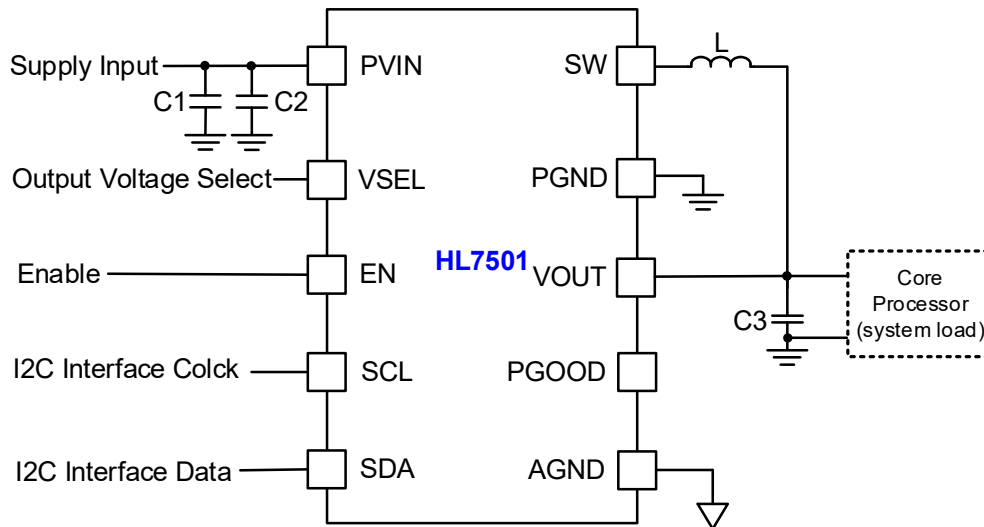

Figure 1 HL7501 Typical Application Diagram

Component	Part Number	Value	Description	Vendor
L1	See Table2	470 or 330 nH	2016	See Table2
C1	C1005X7R1E103K (GRM155R71E103K)	10nF	10V,X7R,0805	TDK (Murata)
C2	C2012X5R1A106M (LMK212BJ106KG-T)	10 μ F	10V,X5R,0805	TDK (Taiyo Yuden)
	C2012X5R0J106M (GRM21BR60J106M)	10 μ F	x2, 6.3V,X5R,0805	TDK (Murata)
C3	C2012X5R0J226M (GRM21BR60J226M)	22 μ F	x2, 6.3V,X5R,0805	TDK (Murata)

Table 1 Recommended External Components with 5A or 6A Max load current

Manufacturer	Part Number	L (nH)	DCR (m Ω)	$I_{MAXDC}^{(1)}$	Component Dimensions		
					L	W	H
TDK	VLC5020T-R47M	470	15	5.4	5	5	2
Bournes	SRP4012-R33M	330	15	6.7	4.7	4.2	1.2
Bournes	SRP4012-R47M	470	20	5	4.7	4.2	1.2
Vishay	IHLP1616ABERR47M01	470	20	5	4.5	4.1	1.2

Table 2 Recommended Inductors for 5A or 6A Max load current

Component	Part Number	Value	Description	Vendor
-----------	-------------	-------	-------------	--------



L1	See Table4	470 or 330 nH	2016	See Table4
C1	TMK063CG100DT-F	10nF	10 nF, 10 V, X5R, 0201	Taiyo Yuden
C2	GRM155R61A106M	10 μ F	10V,X5R,0402	Murata
C3	C1608X5R0J226M	22 μ F	x2,6.3V,X5R,0603 (for 04,06 option)	TDK
	C1608X5R0J226M	22 μ F	6.3 V, X5R, 0603 (for 07 option)	TDK

Table 3 Recommended External Components with 4A or 3A Max load current

Manufacturer	Part Number	L (nH)	DCR(m Ω)	I _{MAXDC} ⁽¹⁾	Component Dimensions		
					L	W	H
Toko	DFE201612R-H-R33N	330	25	3.2	2	1.6	1.2
Cyntek	PIFE20161B-R47MS-39	470	30	3.1	2	1.6	1.2
SEMCO	CIGT201610HMR47SCE	470	30	3.1	2	1.6	0.9
Toko	DFE201612C-R47N	470	40	3.2	2	1.6	1.2

Table 4 Recommended Inductors for 4A or 3A Max load current

Notes:

1. I_{MAXDC} is the smaller current to produce 40°C temperature rise or 30% effective inductance reduction.



Description

HL7501 is a synchronous buck converter optimized to supply different sub systems of portable applications. Its input voltage range is 2.5V to 5.5V. Its output voltage range is 0.6V to 1.42V programmed through an I²C interface. Its output voltage can be adjusted on the fly to provide Dynamic Voltage Scaling (DVS) function with a programmable slew rate.

HL7501 can deliver up to 6A, while maintaining over 80% efficiency at load currents as low as 10mA. Maximum load current of up to 7.5A can be supported for 50ms. It operates at fixed frequency of 2.4MHz, which reduces the value of the external components. A wide range of output capacitors can be used to optimize V_{OUT} stability during load transients. Inductors from 0.33uH to 1.0uH may be used without affecting loop stability.

At moderate to light loads, Pulse Frequency Modulation (PFM) is used to maintain conversion efficiency with a typical non-switching quiescent current of 60μA. Even with such a low quiescent current, HL7501 maintains excellent load and line transient responses. At higher loads, the system automatically switches to fixed-frequency Pulse Width Modulation (PWM) operation at 2.4MHz for minimum V_{OUT} ripple and optimal load transient response. In Shutdown Mode, the supply current drops below 1μA, reducing power consumption. PFM Mode can be disabled if needed through I²C registers.

HL7501 is available in a 20-bump, 0.4mm pitch, 2.0mmx1.6mm Wafer-Level Chip-Scale package (CSP).