



## 2.2MHz 3A Buck Converter

### Features

- Input Voltage Range: 2.5V~5.5V
- Output Voltage Range: 0.6V~4.2V
- Maximum Output Current: 3A
- 2.2MHz PWM with Seamless PWM/PFM Switching for Light-load Efficiency
- Excellent Load and Line Transient
- Quiescent Current in PFM Tristate: 50uA
- Comprehensive Protection
  - Input Under-Voltage Lockout (UVLO)
  - Over Current and Short-Circuit Protection
  - Thermal Shut-down
- Active Discharge When Disabled
- Automatic PFM
- Enable Input
- Power Good Output
- Soft Start

- Over Current Protection
- 2mm x 2mm DFN-8 Package

### Applications

- Memory, Hard Disk Drive and SSD
- Data Cards
- Smart Phones
- Tablets
- Handheld Devices
- LCD TV
- Set Top Box
- Access Point Router

### Order Information

Part Number	V <sub>OUT</sub>	Max Load Current
HL7505FN35	3.500V	3A
HL7505FN33	3.300V	3A
HL7505FN24	2.400V	3A
HL7505FN42	4.200V	3A
HL7505FN06	0.600V	3A
HL7505FN10	1.000V	3A
HL7505FN12	1.200V	3A
HL7505FN15	1.500V	3A
HL7505FN18	1.800V	3A
HL7505FN25	2.500V	3A
HL7505SFN33	3.300V	3A

For other default output voltage and maximum load current options, contact a Halo Micro sales representative.



## Typical Application Diagram

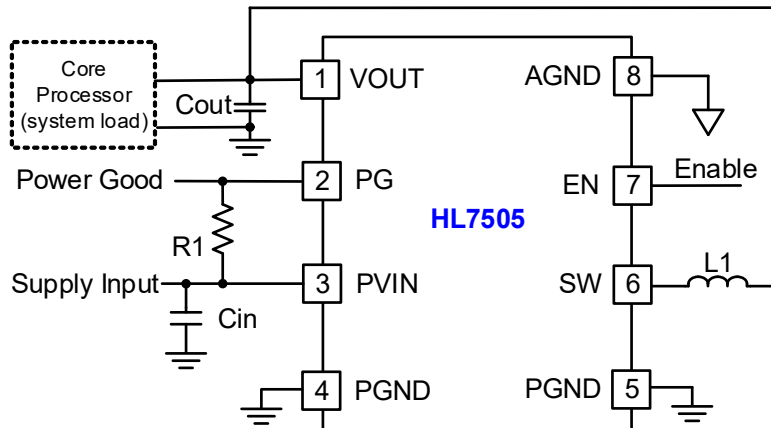

Figure 1 HL7505FN Typical Application Diagram

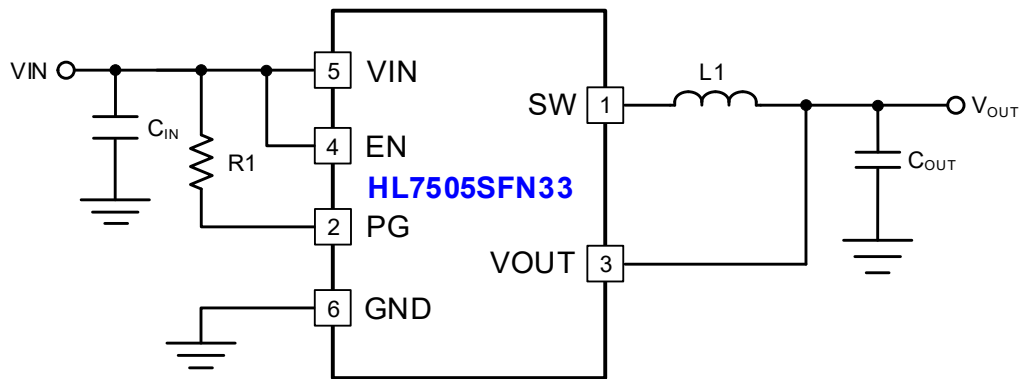

Figure 2 HL7505SFN33 Typical Application Diagram

Component	Part Number	Value	Size	Vendor
L1	See Table2	1.0 or 0.47 uH	2016	See Table2
R1	--	10kΩ	--	TDK
Cin, Cout	C1608X5R1A106M	10uF/10V	0603	TDK

Table 1 Recommended External Components

Manufacturer	Part Number	L (nH)	R <sub>DC</sub> (mΩ)	I <sub>MAXDC</sub> <sup>(1)</sup> (A)	Component Dimensions		
					L	W	H
TDK	TFM201610ALM-1R0MTAA	1000	56	4.3	2.0	1.6	1.0
TDK	TFM201610ALM-R47MTAA	470	34	5.8	2.0	1.6	1.0

Table 2 Recommended Inductors

### Notes:

1. I<sub>MAXDC</sub> is the smaller current to produce 40°C temperature rise or 30% effective inductance reduction.



## Description

HL7505 is a synchronous buck converter optimized to supply different sub systems of portable applications. Its input voltage range is 2.5V to 5.5V.

HL7505 can deliver up to 3.0A with 80% efficiency, while maintaining over 80% efficiency at load currents as low as 10mA. It operates at a high frequency of 2.2MHz, which greatly reduces the value of the external components. A wide range of output capacitors can be used to optimize  $V_{OUT}$  stability during load transients. Inductors from 0.33uH to 1.0uH may be used without affecting loop stability.

At moderate to light loads, Pulse Frequency Modulation

(PFM) is used to maintain conversion efficiency with a typical non-switching quiescent current of 50uA. Even with such a low quiescent current, HL7505 maintains excellent load and line transient responses. At higher loads, the system automatically switches to fixed-frequency Pulse Width Modulation (PWM) operation at 2.2MHz for minimum  $V_{OUT}$  ripple and optimal load transient response. In Shutdown Mode, the supply current drops below 1uA, reducing power consumption.

The HL7505 is available in 8-Pin, 0.5mm pitch, 2mmx2mm DFN package.