



## I<sup>2</sup>C Programmable 3A DVS Buck Converter

### Features

- Input Voltage Range: 2.5V~5.5V
- Programmable Output Voltage:
  - 0.600V to 1.394V in 6.25 mV Steps
- Maximum Output Current: 3A
- 2.4 MHz PWM with Seamless PWM/PFM Switching for Light-load Efficiency
- Dynamic Voltage Scaling (DVS) with Programmable Voltage Slew Rate
- Excellent Load and Line Transient
- Quiescent Current in PFM Tristate: 48μA
- I<sup>2</sup>C Interface with SM, FM, FM<sup>+</sup> and HS Modes

- Comprehensive Protection
  - Input Under-Voltage Lockout (UVLO)
  - Input Over-Voltage Protection (OVP)
  - Over Current and Short-Circuit Protection
  - Thermal Shut-down
- 2.01mm x 1.21mm 15-Bump WLCSP

### Applications

- Application Processors
- Memory, Hard Disk Drive and SSD
- Smart Phones
- Tablets
- Handheld Devices

### Order Information

Part Number	Default V <sub>OUT</sub> after POR		Default mode after POR		I <sup>2</sup> C Address	Package	Packing Method
	VSEL=0	VSEL=1	VSEL=0	VSEL=1			
HL7593WL01	0.600V	0.600V	Auto PFM	Forced PWM	1010 000	WLCSP	Tape & Reel
HL7593WL02	1.125V	1.125V	Auto PFM	Forced PWM	1010 111	WLCSP	Tape & Reel
HL7593WL03	1.125V	1.125V	Auto PFM	Forced PWM	1100 000	WLCSP	Tape & Reel
HL7593WL04	0.600V	0.600V	Auto PFM	Forced PWM	1100 000	WLCSP	Tape & Reel
HL7593WL05	1.150V	0.800V	Forced PWM	Auto PFM	1100 000	WLCSP	Tape & Reel
HL7593WL06	1.150V	0.800V	Forced PWM	Auto PFM	1100 001	WLCSP	Tape & Reel
HL7593WL07	1.200V	1.200V	Auto PFM	Forced PWM	1100 000	WLCSP	Tape & Reel



## Typical Application Diagram

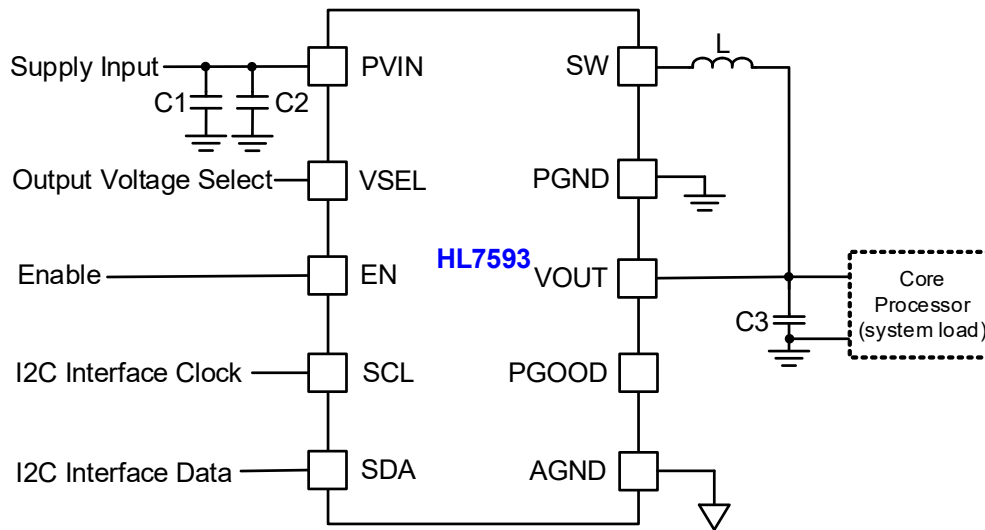

Figure 1 HL7593 Typical Application Diagram

Component	Part Number	Value	Size	Vendor
L1	See Table2	470 or 330 nH	2016	See Table2
C1, C2	C1608X5R1A475K	4.7 $\mu$ F/10V	0603	TDK
C3	C1608X5R0J226M	22 $\mu$ F/6.3V	0603	TDK

Table 1 Recommended External Components

Manufacturer	Part Number	L (nH)	DCR(m $\Omega$ )	$I_{MAXDC}^{(1)}$	Component Dimensions		
					L	W	H
Toko	DFR201612C-R33N	330	23	4.2	2	1.6	1.2
Cyntek	PIFE20161B-R33MS	330	27	3.5	2	1.6	1.2
Toko	DFE201612C-R47N	470	40	3.2	2	1.6	1.2
Cyntek	PIFE20161B-R47MS-39	470	30	3.1	2	1.6	1.2
SEMCO	CIGT201610UMR47MNE	470	30	4	2	1.6	0.9

Table 2 Recommended Inductors

### Notes:

- $I_{MAXDC}$  is the smaller current to produce 40°C temperature rise or 30% effective inductance reduction.



## Description

HL7593 is a synchronous buck converter optimized to supply different sub systems of portable applications. Its input voltage range is 2.5V to 5.5V. Its output voltage range is 0.600V to 1.394V in 6.25mV steps, programmed through an I<sup>2</sup>C interface. Its output voltage can be adjusted on the fly to provide Dynamic Voltage Scaling (DVS) function with a programmable slew rate.

HL7593 can deliver up to 3A with 80% efficiency, while maintaining over 80% efficiency at load currents as low as 10mA. It operates at fixed frequency of 2.4MHz, which reduces the value of the external components. A wide range of output capacitors can be used to optimize V<sub>OUT</sub> stability during load transients. Inductors from 0.33uH to 1.0uH may be used without affecting loop stability.

At moderate to light loads, Pulse Frequency Modulation (PFM) is used to maintain conversion efficiency with a typical non-switching quiescent current of 48μA. Even

with such a low quiescent current, HL7593 maintains excellent load and line transient responses. At higher loads, the system automatically switches to fixed-frequency Pulse Width Modulation (PWM) operation at 2.4MHz for minimum V<sub>OUT</sub> ripple and optimal load transient response. In Shutdown Mode, the supply current drops below 1μA, reducing power consumption. PFM Mode can be disabled if needed through I<sup>2</sup>C registers.

HL7593 supports V<sub>OUT</sub> remote sensing. It's feedback signal V<sub>OUT</sub> can be connected close to the power supply pin of the load for a true point-of-load operation without affecting control loop stability.

The HL7593 is available in a 15-bump, 0.4mm pitch, 2.01mm x 1.21mm WLCSP.