



2A Boost Regulator with Bypass Mode

Features

- Input Voltage Range: 2.35V~5.50V
- Fixed Output Voltage Options: 3V~ 6V
- Maximum Output Current: 2A
- 2.5MHz Operation Frequency with Seamless PWM/PFM Transition for Light-load Efficiency
- Optional Auto Bypass Mode and Forced Bypass Mode
- VSEL Control (HL7600WL01 and HL7600WL02) to Optimize Target V_{OUT}
- Output Capacitor Discharge
- Low Operating Quiescent Current
- Comprehensive Protection
 - Input Under-Voltage Lockout (UVLO)
 - Over Current and Short-Circuit Protection
 - Thermal Shut-down
- Soft Start
- 16-Bump, 0.4mm Pitch WLCSP

Applications

- Smart Phone and Tablet PC
- Wireless Communication Device
- 2G/3G/4G RF Power Amplifier
- Audio Power Amplifier
- USB OTG Power Source

Order Information

Part Number	VSEL Function	FB Function	Max Load Current
HL7600WL01	Enable. $V_{SEL}=0$, $V_{OUT}=4.8V$; $V_{SEL}=1$, $V_{OUT}=5.35V$.	Disable. Connecting FB to GND through 10K resistor is recommended.	2A
HL7600WL02	Enable. $V_{SEL}=0$, $V_{OUT}=5.0V$; $V_{SEL}=1$, $V_{OUT}=5.85V$.	Disable. Connecting FB to GND through 10K resistor is recommended.	2A
HL7600WL03	Disable. Connecting VSEL to GND through 10K resistor is recommended.	Enable. V_{OUT} is set by FB, not VSEL.	2A

For other default output voltage and maximum load current options, contact a Halo Micro sales representative.



Typical Application Diagram

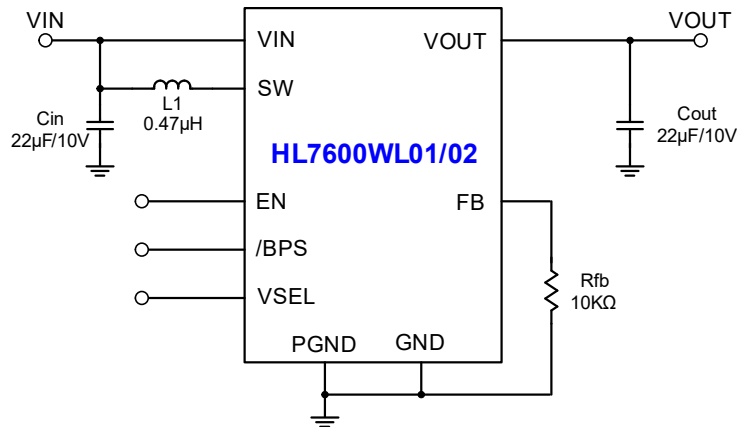

Figure 1 HL7600WL01/02 Typical Application Diagram, Set V_{OUT} by VSEL

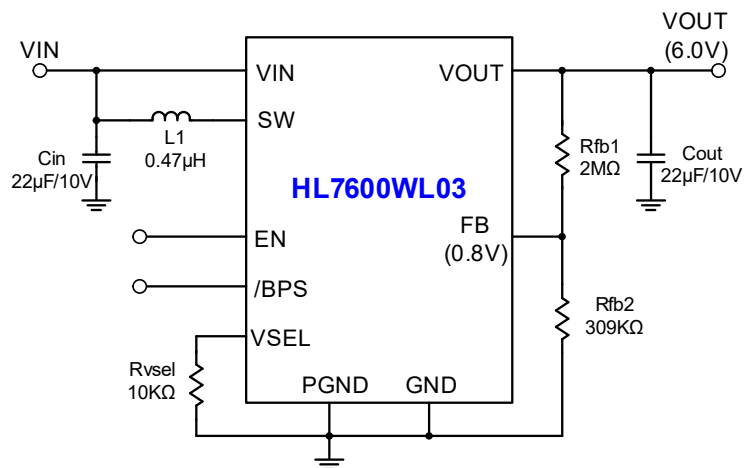

Figure 2 HL7600WL03 Typical Application Diagram, Set V_{OUT} by FB

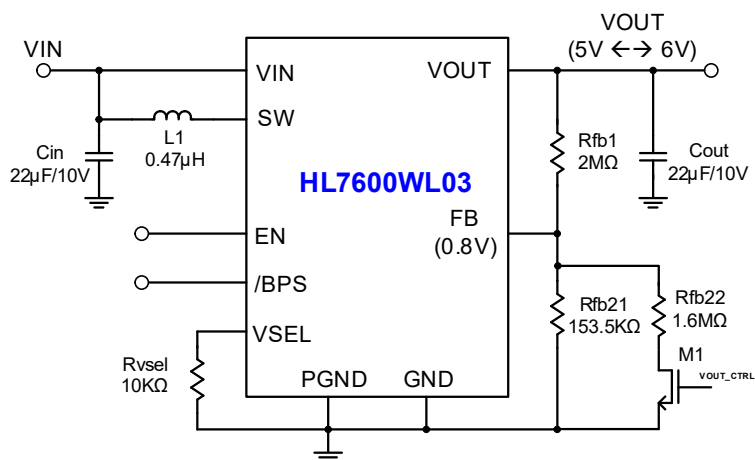

Figure 3 HL7600WL03 Typical Application Diagram, Set V_{OUT} by V_{OUT_CTRL}

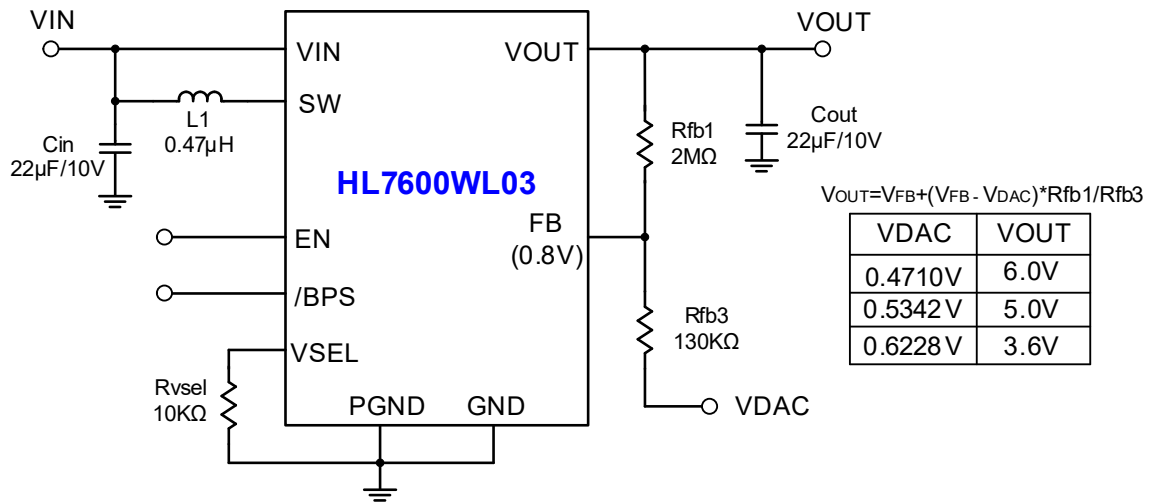

Figure 4 HL7600WL03 Typical Application Diagram, Set V_{OUT} by V_{DAC}

Component	Part Number	Value	Size	Vendor
Cin	CL10A226MP8NRNC	22uF/10V, 20%	0603 (1.6x0.8x0.8mm)	Samsung
Cout	CL10A226MP8NRNC	22uF/10V, 20%	0603 (1.6x0.8x0.8mm)	Samsung
L1	WPN252010HR47MT	0.47uH/5.8A	2520	SUNLORD
Rvsel		10K Ω		
Rfb		10K Ω		
Rfb1		2M Ω		
Rfb2		309K Ω		
Rfb21		153.5 Ω		
Rfb22		1.6M Ω		
Rfb3		130K Ω		

Table 1 Recommended External Components



Description

The HL7600 provides a power supply solution for products powered by Li-Ion Battery. By combining built-in power transistors, synchronous rectification, and low supply current, this IC is optimized for single-cell portable applications like in smart-phones or tablet PCs.

The HL7600 is a boost regulator designed to provide a minimum output voltage from a single-cell Li-Ion battery, even when the battery voltage is below system minimum. This extends the battery run-time and overcomes input

current and voltage limitations of the powered system. The output voltage regulation is guaranteed up to a maximum load current of 2A. The regulator transitions smoothly between Bypass and normal Boost Mode. The device can be forced into Bypass Mode to reduce quiescent current.

The HL7600 is available in a 16-bump, 0.4mm pitch, Wafer-Level Chip-Scale Package (WLCSP).