



## 2.5MHz High Efficiency Boost Converter

### Features

- 95% Efficiency at 2.5MHz Operation
- 25 $\mu$ A Quiescent Current in Standby Mode
- 58 $\mu$ A Quiescent Current in Normal Operation
- Wide VIN Range From 2.5V to 5.5V
- VIN  $\geq$  VOUT Operation
- $\pm 2\%$  Total DC Voltage Accuracy
- Light-Load PFM Mode
- Selectable Standby Mode or True Load
- Disconnect During Shutdown
- Thermal Shutdown and Overload Protection
- Only Three Surface-Mount External Components Required
- 9-Bump WLCSP or DFN-6 Packaging

### Applications

- Cell Phones, Smart Phones
- Mono and Stereo APA Applications
- USB Charging Ports (5V)

### Order Information

Part Number	Switching Frequency	V <sub>OUT</sub>	BP/AGND	Package	Body Size
HL7612WL01	2.5MHz	5.0V	BP	WLCSP	1.20 mm x 1.20 mm
HL7612WL02	2.5MHz	5.4V	BP	WLCSP	1.20 mm x 1.20 mm
HL7612WL03	2.5MHz	4.5V	BP	WLCSP	1.20 mm x 1.20 mm
HL7612WL04	2.5MHz	6.0V	BP	WLCSP	1.20 mm x 1.20 mm
HL7612WL05	2.5MHz	5.0V	AGND	WLCSP	1.20 mm x 1.20 mm
HL7612FN01	2.5MHz	5.0V	BP	DFN	2.00 mm x 2.00 mm

**For other default output voltage and maximum load current options, contact a Halo Micro sales representative.**



## Typical Application Diagram

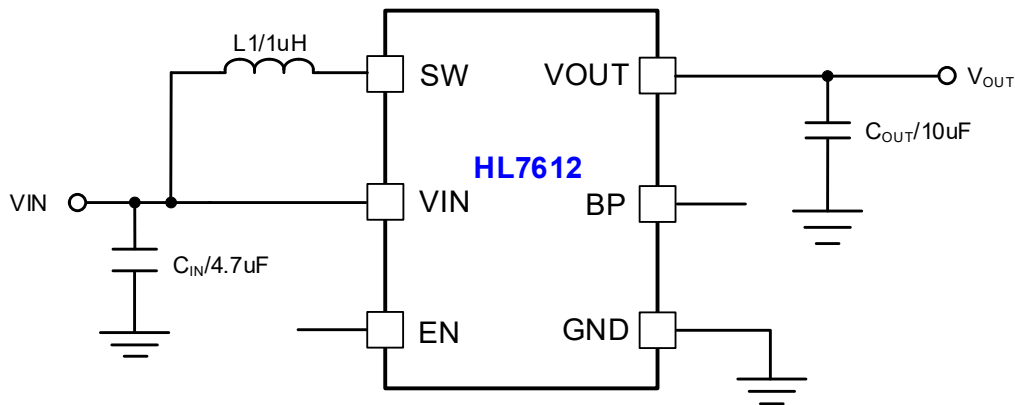

Figure 1 HL7612WL01/02/03/04, HL7612FN01 Typical Application Diagram

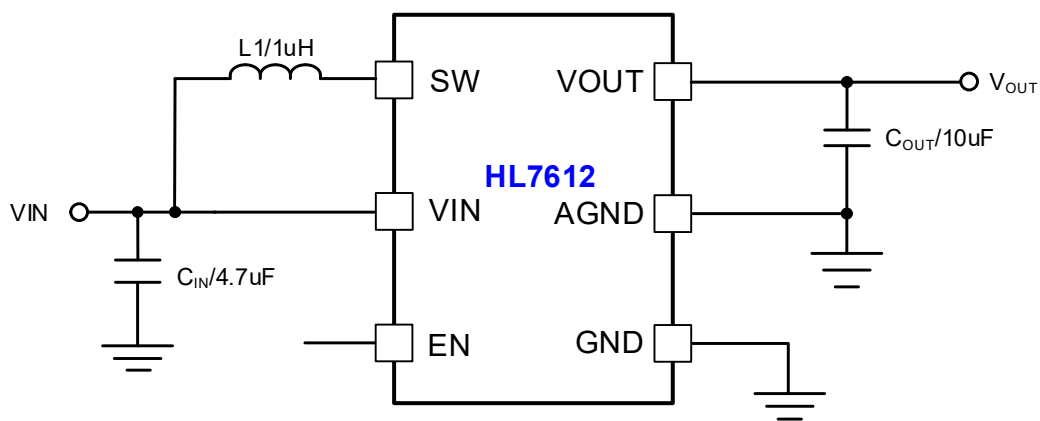

Figure 2 HL7612WL05 Typical Application Diagram

Component	Part Number	Value	Size	Vendor
C <sub>IN</sub>	GRM155R60J475M	4.7uF/6.3V,20%	0420	MURATA
C <sub>OUT</sub>	GRM188R60J106ME84	10uF/6.3V,20%	0603	MURATA
L1	HMLQ20161B-1R0MDR	1.0uH	2016	See Table2

Table 1 Recommended External Components

Manufacturer	Part Number	L (nH)	R <sub>Dc</sub> (mΩ)	I <sub>MAXDC</sub> <sup>(1)</sup> (A)	Component Dimensions		
					L(mm)	W(mm)	H(mm)
CYNTEC	HMLQ20161B-1R0MDR	1000	50	3.0	2.0	1.6	1.0

Table 2 Recommended Inductors

### Notes:

1. I<sub>MAXDC</sub> is the smaller current to produce 40°C temperature rise or 30% effective inductance reduction.



## Description

The HL7612 device provides a power supply solution for battery-powered portable applications. Intended for low-power applications, the HL7612 supports up to 1.5A load current from a battery discharged as low as 2.5V and allows the use of low cost chip inductor and capacitors.

With a wide input voltage range of 2.5 V to 5.5 V, the device supports applications powered by Li-Ion batteries with extended voltage range. Different fixed voltage output versions are available from 3.8V to 6.0 V.

The HL7612 operates at a regulated 2.5MHz switching frequency and enters power-save mode operation at light load currents to maintain high efficiency over the entire load current range. The PFM mode extends the battery life by reducing the quiescent current to 58 $\mu$ A (typ)

during light load operation.

In addition, the HL7612 device can also maintain its output biased at the input voltage level. In this mode, the synchronous rectifier is current limited allowing external load (e.g. audio amplifier) to be powered with a restricted supply. In this mode, the quiescent current is reduced to 25 $\mu$ A. During shutdown, the load is completely disconnected from the battery. Input current in shutdown mode is less than 1 $\mu$ A (typ), which maximizes battery life.

The HL7612 offers a very small solution size due to minimum amount of external components. It allows the use of small inductors and input capacitors to achieve a small solution size.