



GaAs PHEMT MMIC MEDIUM POWER AMPLIFIER, 17.5 - 24.0 GHz

Typical Applications

The HMC442LM1 is an ideal gain block or driver amplifier for:

- Point-to-Point Radios
- Point-to-Multi-Point Radios
- VSAT

Features

- Saturated Power: +23 dBm @ 27% PAE
- Gain: 14 dB
- Supply Voltage: +5V
- 50 Ohm Matched Input/Output

Functional Diagram

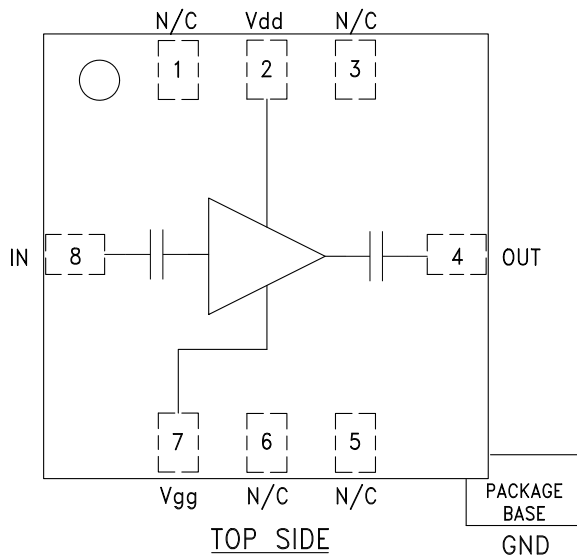

General Description

The HMC442LM1 is a broadband 17.5 to 24 GHz GaAs PHEMT MMIC Medium Power Amplifier in a SMT leadless chip carrier package. The LM1 is a true surface mount broadband millimeterwave package offering low loss & excellent I/O match, preserving MMIC chip performance. The amplifier provides 14 dB of gain and +23 dBm of saturated power at 27% PAE from a +5V supply voltage. This 50 Ohm matched amplifier has integrated DC blocks on RF in and out and makes an ideal linear gain block, transmit chain driver or LO driver for HMC SMT mixers. As an alternative to chip-and-wire hybrid assemblies the HMC442LM1 eliminates the need for wirebonding, thereby providing a consistent connection interface for the customer.

Electrical Specifications, $T_A = +25^\circ C$, $V_{dd} = 5V$, $I_{dd} = 85 mA^*$

Parameter	Min.	Typ.	Max.	Min.	Typ.	Max.	Units
Frequency Range	17.5 - 21.0		21.0 - 24.0		GHz		
Gain	10.5	13		10.5	14		dB
Gain Variation Over Temperature		0.02	0.03		0.02	0.03	dB/ °C
Input Return Loss		10			10		dB
Output Return Loss		7			8		dB
Output Power for 1 dB Compression (P1dB)	17	20		18.5	21.5		dBm
Saturated Output Power (P _{sat})		23			23.5		dBm
Output Third Order Intercept (IP3)		28			27		dBm
Noise Figure		7			6.5		dB
Supply Current (I _{dd})(V _{dd} = 5V, V _{gg} = -1V Typ.)		85			85		mA

*Adjust V_{gg} between -1.5 to -0.5V to achieve I_{dd} = 85 mA typical.



**GaAs PHEMT MMIC MEDIUM
POWER AMPLIFIER, 17.5 - 24.0 GHz**

Broadband Gain & Return Loss

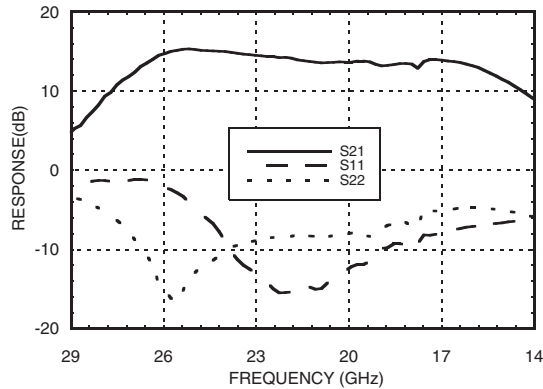

Gain vs. Temperature

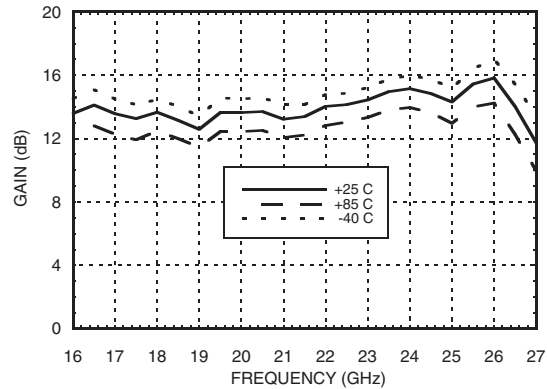

Input Return Loss vs. Temperature

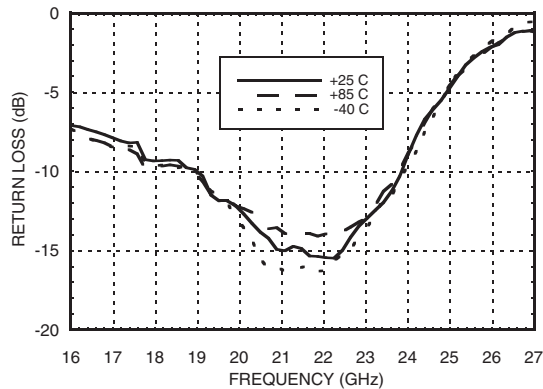

Output Return Loss vs. Temperature

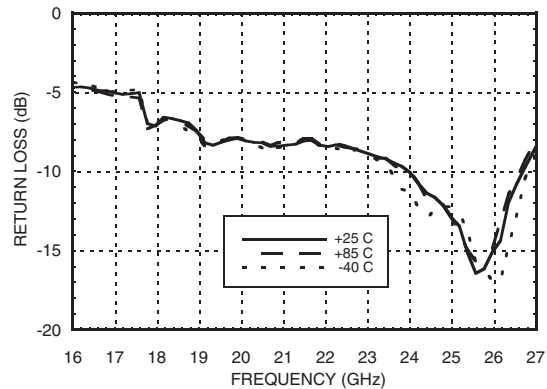

P1dB vs. Temperature

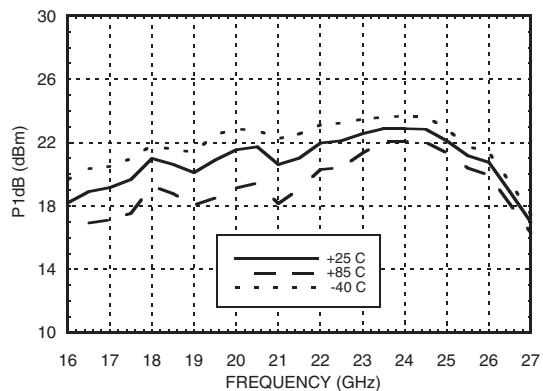

Psat vs. Temperature

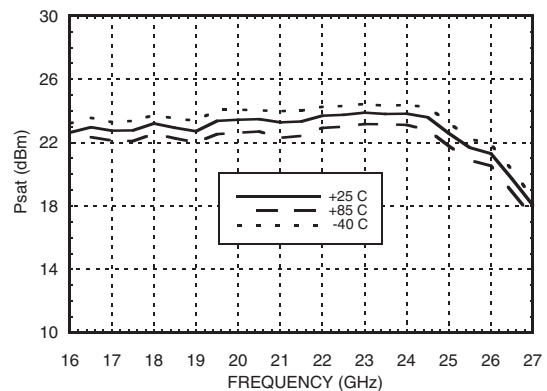

Information furnished by Analog Devices is believed to be accurate and reliable. However, no responsibility is assumed by Analog Devices for its use, nor for any infringements of patents or other rights of third parties that may result from its use. Specifications subject to change without notice. No license is granted by implication or otherwise under any patent or patent rights of Analog Devices. Trademarks and registered trademarks are the property of their respective owners.

For price, delivery, and to place orders: Analog Devices, Inc., One Technology Way, P.O. Box 9106, Norwood, MA 02062-9106 Phone: 781-329-4700 • Order online at www.analog.com Application Support: Phone: 1-800-ANALOG-D



GaAs PHEMT MMIC MEDIUM POWER AMPLIFIER, 17.5 - 24.0 GHz

Power Compression @ 18 GHz

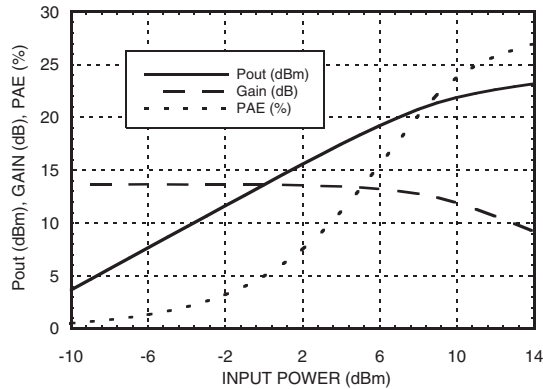

Power Compression @ 23 GHz

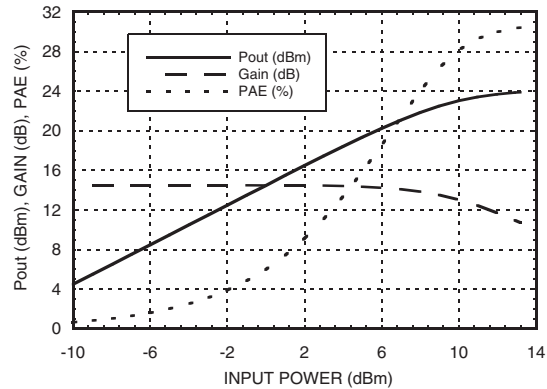

Output IP3 vs. Temperature

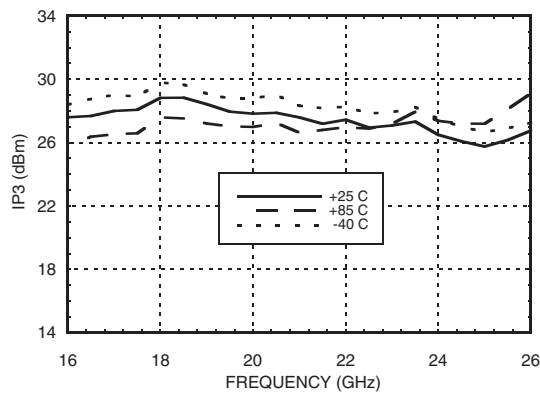

Noise Figure vs. Temperature

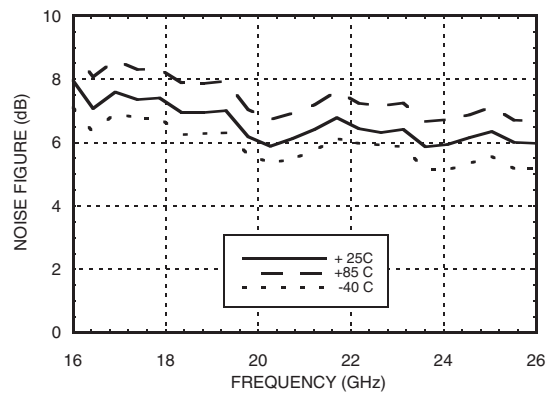

Gain & Power vs. Supply Voltage @ 23 GHz

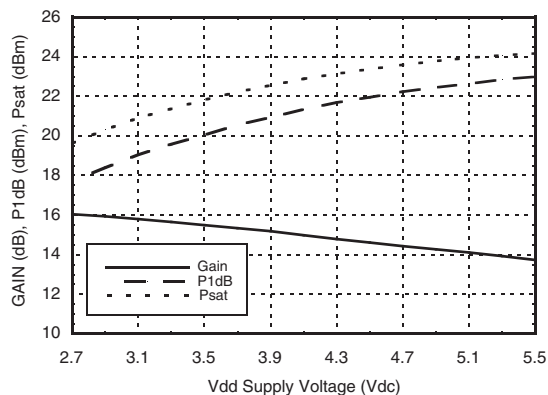

Reverse Isolation vs. Temperature

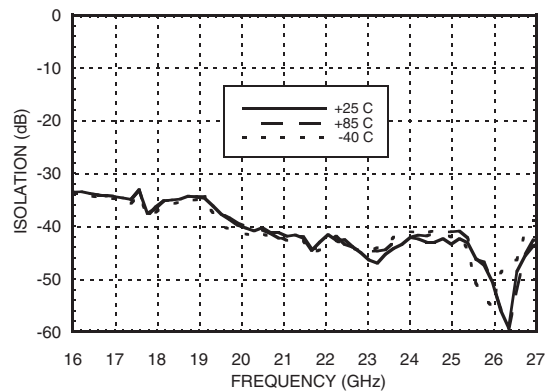

Information furnished by Analog Devices is believed to be accurate and reliable. However, no responsibility is assumed by Analog Devices for its use, nor for any infringements of patents or other rights of third parties that may result from its use. Specifications subject to change without notice. No license is granted by implication or otherwise under any patent or patent rights of Analog Devices. Trademarks and registered trademarks are the property of their respective owners.

For price, delivery, and to place orders: Analog Devices, Inc., One Technology Way, P.O. Box 9106, Norwood, MA 02062-9106 Phone: 781-329-4700 • Order online at www.analog.com Application Support: Phone: 1-800-ANALOG-D

GaAs PHEMT MMIC MEDIUM POWER AMPLIFIER, 17.5 - 24.0 GHz



Absolute Maximum Ratings

Drain Bias Voltage (Vdd)	+5.5 Vdc
Gate Bias Voltage (Vgg)	-8.0 to 0 Vdc
RF Input Power (RFIN)(Vdd = +5Vdc, Idd = 85 mA)	+16 dBm
Channel Temperature	175 °C
Continuous P _{diss} (T = 85 °C) (derate 5.46 mW/°C above 85 °C)	0.491 W
Thermal Resistance (channel to ground paddle)	183 °C/W
Storage Temperature	-65 to +150 °C
Operating Temperature	-40 to +85 °C

Typical Supply Current vs. Vdd

Vdd (V)	Idd (mA)
+4.5	82
+5.0	85
+5.5	87
+2.7	79
+3.0	83
+3.3	86

Note: Amplifier will operate over full voltage range shown above



**ELECTROSTATIC SENSITIVE DEVICE
OBSERVE HANDLING PRECAUTIONS**

Outline Drawing

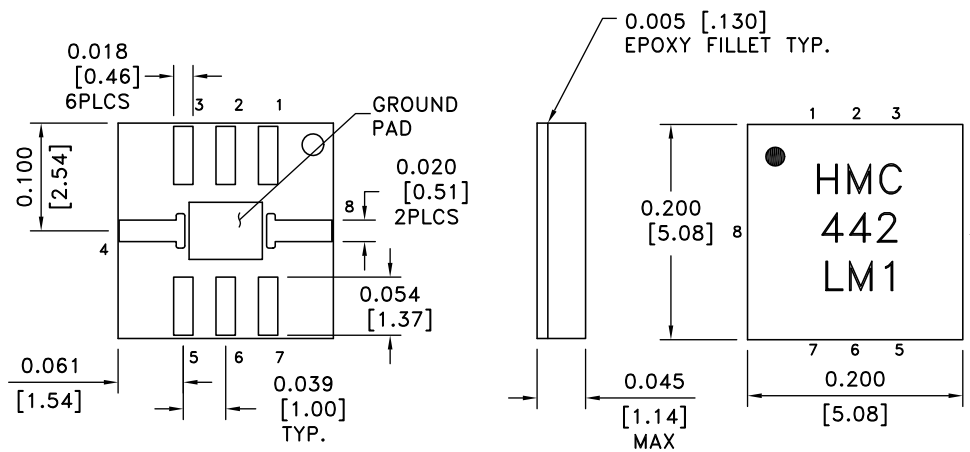

NOTES:

1. MATERIAL: PLASTIC
2. PLATING: GOLD OVER NICKEL
3. DIMENSIONS ARE IN INCHES [MILLIMETERS].
4. ALL TOLERANCES ARE ±0.005 [±0.13].
5. ALL GROUNDS MUST BE SOLDERED TO PCB RF GROUND.
6. • INDICATES PIN 1.

GaAs PHEMT MMIC MEDIUM POWER AMPLIFIER, 17.5 - 24.0 GHz

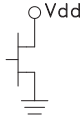
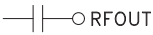
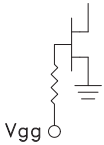
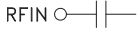

Pin Descriptions

Pin Number	Function	Description	Interface Schematic
1, 3, 5, 6	N/C	No connection	
2	Vdd	Power Supply Voltage for the amplifier. External bypass capacitors of 100 pF and 0.01 μ F are required.	
4	RFOUT	This pin is AC coupled and matched to 50 Ohms.	
7	Vgg	Gate control for amplifier. Adjust to achieve Id of 85 mA. Please follow "MMIC Amplifier Biasing Procedure" Application Note.	
8	RFIN	This pin is AC coupled and matched to 50 Ohms.	

GaAs PHEMT MMIC MEDIUM POWER AMPLIFIER, 17.5 - 24.0 GHz



Evaluation PCB

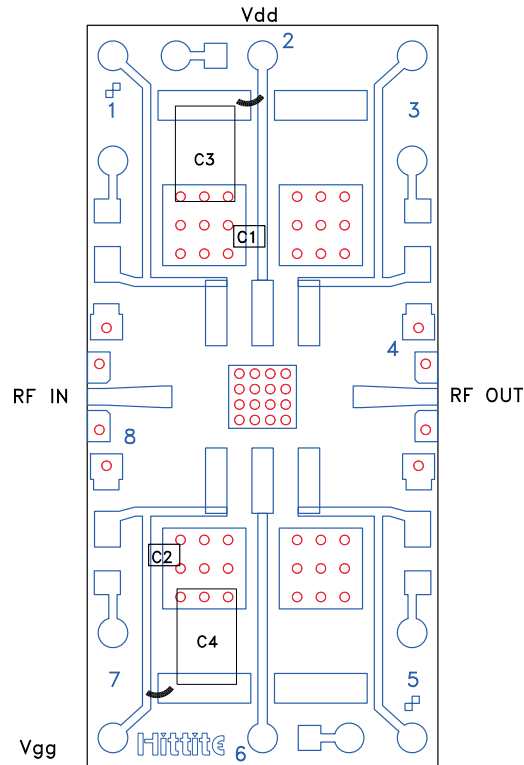

The grounded Co-Planar Wave Guide (CPWG) PCB input/output transitions allow use of Ground-Signal-Ground (GSG) probes for testing. Suggested probe pitch is 400um (16 mils). Alternatively, the board can be mounted in a metal housing with 2.4mm coaxial connectors.

Evaluation Circuit Board Layout Design Details

Layout Technique	Micro Strip to CPWG
Material	Rogers 4003 with 1/2 oz, Cu
Dielectric Thickness	0.008" (0.20 mm)
Microstrip Line Width	0.018" (0.46 mm)
CPWG Line Width	0.016" (0.41 mm)
CPWG Line to GND Gap	0.005" (0.13 mm)
Ground VIA Hole Diameter	0.008" (0.20 mm)
C1 - C2	100 pF Capacitor, 0402 Pkg.
C3 - C4	33.000 pF Capacitor, 0805 Pkg.

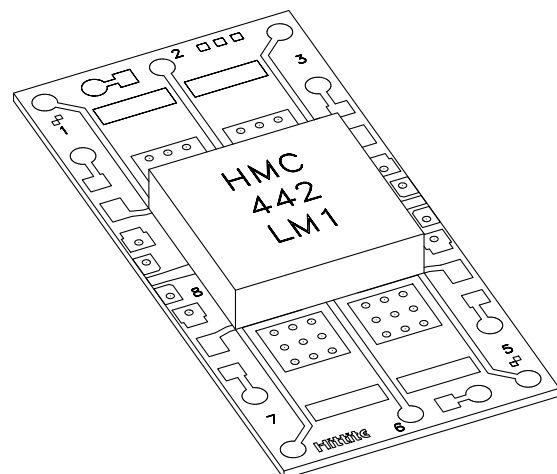

GaAs PHEMT MMIC MEDIUM POWER AMPLIFIER, 17.5 - 24.0 GHz



Suggested LM1 PCB Land Pattern Tolerance: $\pm 0.003''$ (± 0.08 mm)

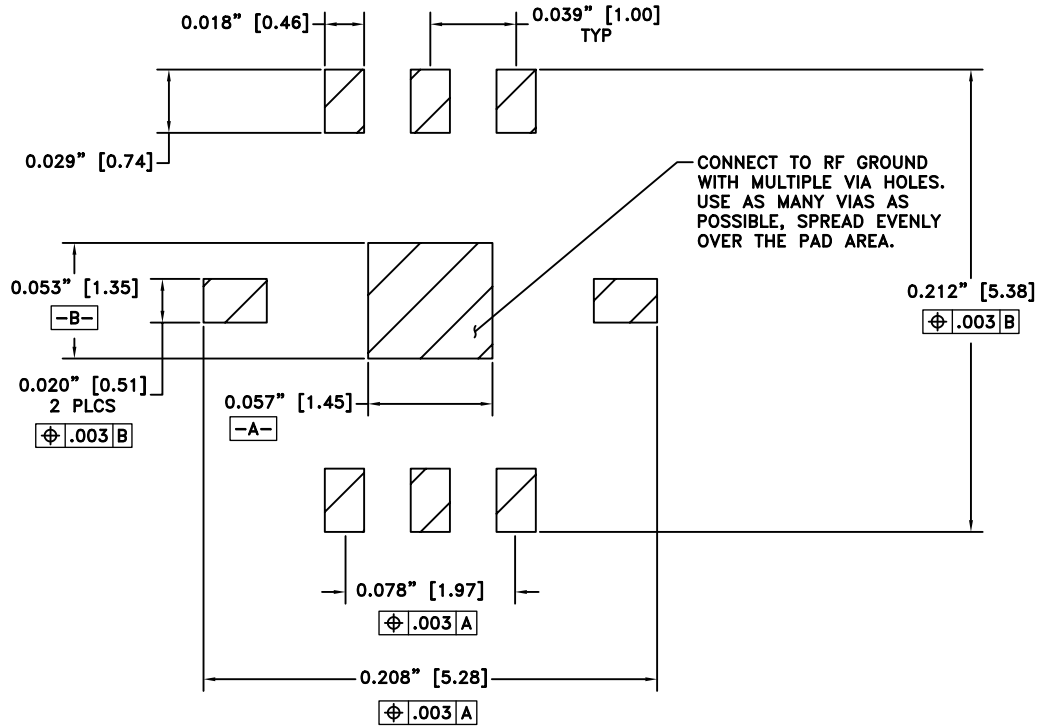

Amplifier Application Circuit

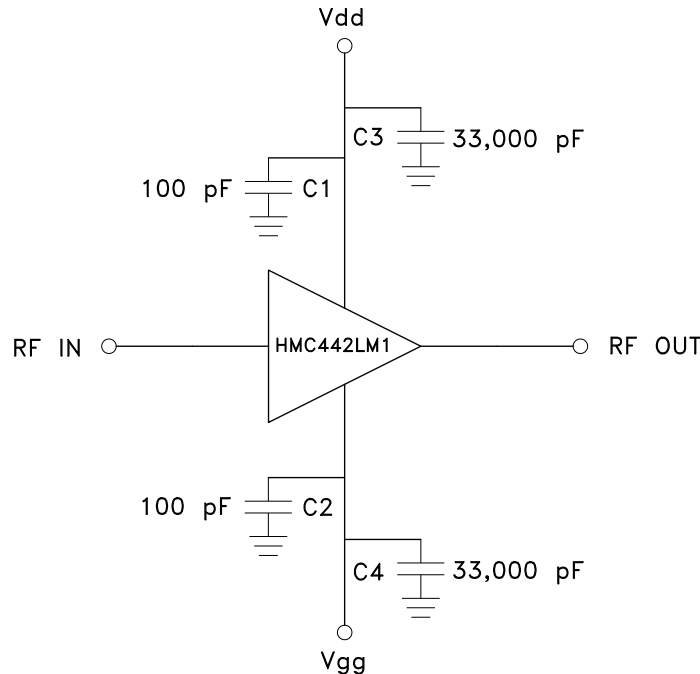

Information furnished by Analog Devices is believed to be accurate and reliable. However, no responsibility is assumed by Analog Devices for its use, nor for any infringements of patents or other rights of third parties that may result from its use. Specifications subject to change without notice. No license is granted by implication or otherwise under any patent or patent rights of Analog Devices. Trademarks and registered trademarks are the property of their respective owners.

For price, delivery, and to place orders: Analog Devices, Inc., One Technology Way, P.O. Box 9106, Norwood, MA 02062-9106 Phone: 781-329-4700 • Order online at www.analog.com Application Support: Phone: 1-800-ANALOG-D