



Main

Range of Product	Harmony GTU
Product or Component Type	Flat screen
Terminal type	Touchscreen display
[Us] rated supply voltage	12...24 V DC power supply
Supply voltage limits	10.8...28.8 V
Power Consumption in W	22 W
Inrush current	30 A

Complementary

Integrated connection type	USB 2.0 type A USB 2.0 type mini B
Touchscreen resolution	1024 x 1024
Pixel resolution	1024 x 768
Display size	15 inch
Aspect ratio	4:3
Display type	Colour TFT LCD
Display Resolution	1024 x 768 pixels XGA
Display colour	16 million colours
Backlight lifespan	50000 hours
Touch panel	Multi touch analogue resistive
Function Available	Brightness sensor
Type of cooling	Natural convection
Type of Installation	Indoor installation
Cut-out dimensions	383.5 (+ 1/- 0) x 282.5 (+ 1/- 0) mm
Width	15.63 in (397 mm)
Height	11.65 in (296 mm)
Depth	2.64 in (67 mm)
Net Weight	9.92 lb(US) (4.5 kg)

Environment

IP degree of protection	Front panel IP66 Front panel IP67
NEMA degree of protection	NEMA 4X front panel
Standards	UL 508 ANSI/ISA 12-12-01 Class I division 2 CSA C22.2 No 213 CSA C22.2 No 142 IEC 61132-2
Product certifications	CULus RCM KC CE UKCA UKEX
Ambient air temperature for operation	32...140 °F (0...60 °C) EN 61131-2
Ambient air temperature for storage	-4...140 °F (-20...60 °C)

Relative Humidity	10...90 % non-condensing
Operating altitude	6561.68 ft (2000 m)
Vibration resistance	3.5 mm constant amplitude 5...9 Hz) EN/IEC 61131-2 9.8 m/s ² 9...150 Hz) EN/IEC 61131-2
Shock resistance	147 m/s ² EN/IEC 61131-2
Electromagnetic compatibility	Electrostatic discharge immunity testlevel 3 EN/IEC 61000-4-2

Ordering and shipping details

Category	22567-MAGELIS HMI GTU
Discount Schedule	MC2
GTIN	3606480687228
Returnability	Yes
Country of origin	CN

Packing Units

Unit Type of Package 1	PCE
Number of Units in Package 1	1
Package 1 Height	5.91 in (15 cm)
Package 1 Width	15.08 in (38.3 cm)
Package 1 Length	20.71 in (52.6 cm)
Package 1 Weight	13.69 lb(US) (6.21 kg)
Unit Type of Package 2	CAR
Number of Units in Package 2	2
Package 2 Height	16.34 in (41.5 cm)
Package 2 Width	21.46 in (54.5 cm)
Package 2 Length	13.58 in (34.5 cm)
Package 2 Weight	481.69 oz (13656 g)
Unit Type of Package 3	P12
Number of Units in Package 3	8
Package 3 Height	37.40 in (95 cm)
Package 3 Width	31.50 in (80 cm)
Package 3 Length	47.24 in (120 cm)
Package 3 Weight	2244.23 oz (63624 g)

Offer Sustainability

Sustainable offer status	Green Premium product
California proposition 65	WARNING: This product can expose you to chemicals including: Lead and lead compounds, which is known to the State of California to cause cancer and birth defects or other reproductive harm. For more information go to www.P65Warnings.ca.gov
REACH Regulation	REACH Declaration
REACH free of SVHC	Yes
EU RoHS Directive	Pro-active compliance (Product out of EU RoHS legal scope) EU RoHS Declaration
Mercury free	Yes
China RoHS Regulation	China RoHS Declaration
RoHS exemption information	Yes
WEEE	The product must be disposed on European Union markets following specific waste collection and never end up in rubbish bins.

Contractual warranty

Warranty	18 months
----------	-----------

External Dimensions

Display Unit with Box Module

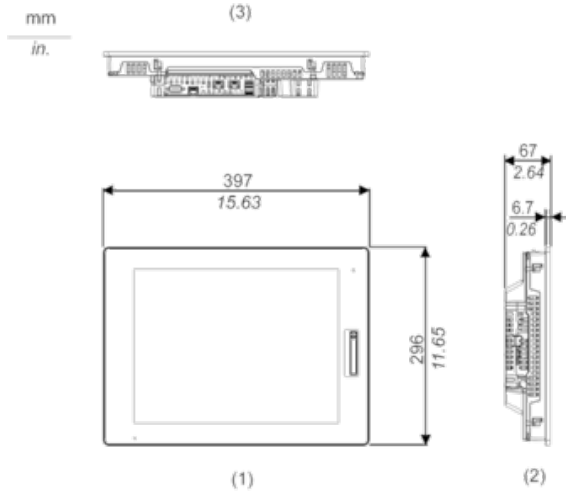

- 1 Front
- 2 Left
- 3 Bottom

Installation with Installation Fasteners and Dimensions with Cables

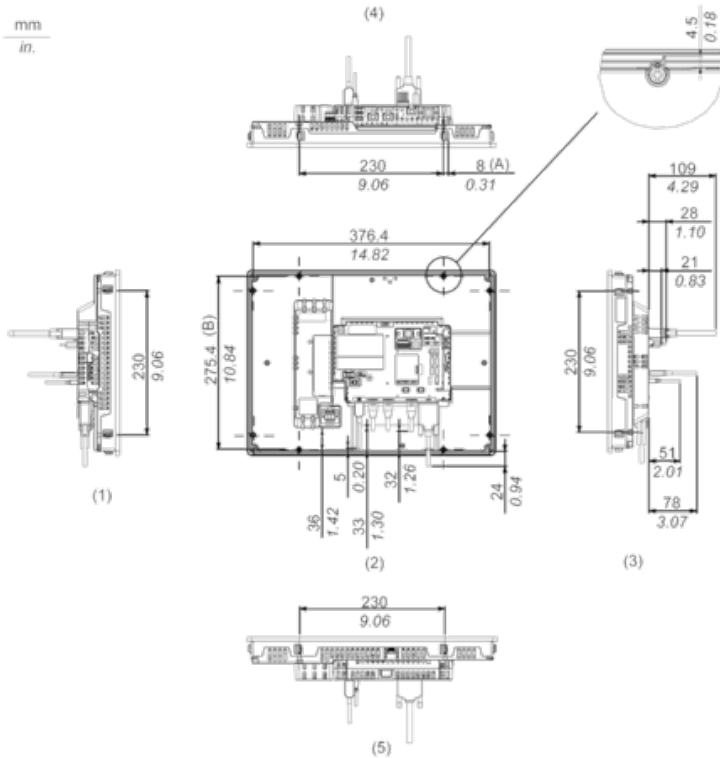

- (A) Rotation area of the fastener
- (B) Pitch of the center of installation fastner screws

- 1 Right
- 2 Front
- 3 Left
- 4 Bottom

