

## HMU series – basic pressure sensors

---

The HMU pressure sensors provide uncalibrated and uncompensated analog mV output signals. They feature an increased media compatibility to measure gases and liquids. Very small SIL and DIP housings allow for space-saving PCB-mounting. All HMU pressure sensors can be modified according to customer specific requirements.

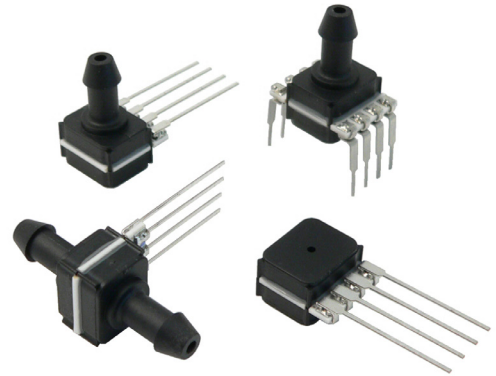

---

### Features

- Pressure ranges from 100 mbar to 10 bar, 1 psi to 150 psi gage or differential pressure
- Increased media compatibility<sup>(1)</sup>
- Wide operating temperature range
- SIL and DIP housings

---

### Certificates

- Quality Management System according to EN ISO 13485:2003 and EN ISO 9001:2008
- RoHS and REACH compliant

---

### Media compatibility<sup>(1, 2)</sup>

**High pressure port:**

To be used with gases and liquids which are compatible with the wetted materials (high temperature polyamide, ceramic  $AL_2O_3$ , epoxy, fluorosilicone, glass, silicon).

**Low pressure port:**

To be used with non-corrosive, non-ionic working fluids such as clean dry air, dry gases and the like.

---

### Applications

- Industrial controls
- Pneumatic controls
- Environmental controls
- HVAC
- Instrumentation
- Analytical instruments
- Medical devices

#### Specification notes

(1) All wetted materials are selected to give a high level of media compatibility. Media compatibility refers to media inside the pressure port and lid. Improved media compatibility on high pressure port (backward side of sensor chip) since media has no contact to electronic components. Nevertheless tests with the media used in the specific application are recommended.

(2) Sensor is specified in air, changes in sensor behaviour based on physical effects caused by the specific media can occur. Weight of the media and wetting forces can influence the sensor characteristics.

## HMU series – basic pressure sensors

### Maximum ratings

Parameter		Min.	Typ.	Max.	Unit
Supply voltage $V_s$			5	12	$V_{DC}$
Temperature ranges	Operating	-40		+85 (+125) <sup>(3)</sup>	°C
	Storage <sup>(4)</sup>	-40		+125	
Humidity limits (non-condensing) <sup>(5)</sup>				95	%RH
Vibration	10...2000 Hz, random (EN 60068-2-64)			10	g
Mechanical shock	11 ms (EN60068-2-27)			50	
Lead solder temperature	(JESD22-B106D)			270	°C

### Pressure sensor characteristics<sup>(2)</sup>

( $V_s=5.0 V_{DC}$ ,  $T_A=25\text{ °C}$ , RH=50 %, pressure applied to high pressure port)

#### Bar pressure ranges

Part no.	Operating pressure	Proof pressure <sup>(6)</sup>	Full scale span <sup>(7)</sup>		
			Min.	Typ.	Max.
HMUM100...	0...100 mbar	2 bar	30 mV	60 mV	120 mV
HMUM350...	0...350 mbar	2 bar	40 mV	100 mV	160 mV
HMUB001...	0...1 bar	5 bar	60 mV	100 mV	140 mV
HMUB2x5...	0...2.5 bar	10 bar	60 mV	100 mV	140 mV
HMUB005...	0...5 bar	14 bar	60 mV	100 mV	140 mV
HMUB010...	0...10 bar	14 bar	60 mV	100 mV	140 mV

#### Psi pressure ranges

Part no.	Operating pressure	Proof pressure <sup>(6)</sup>	Full scale span <sup>(7)</sup>		
			Min.	Typ.	Max.
HMUM100...	0...1 psi	30 psi	20 mV	41 mV	83 mV
HMUM350...	0...5 psi	30 psi	39 mV	98 mV	158 mV
HMUB001...	0...15 psi	75 psi	61 mV	103 mV	145 mV
HMUB2x5...	0...35 psi	150 psi	57 mV	96 mV	136 mV
HMUB005...	0...70 psi	200 psi	58 mV	96 mV	136 mV
HMUB010...	0...100 psi	200 psi	41 mV	70 mV	97 mV
	0...150 psi	200 psi	61 mV	103 mV	145 mV

#### Specification notes

- (2) Sensor is specified in air, changes in sensor behaviour based on physical effects caused by the specific media can occur. Weight of the media and wetting forces can influence the sensor characteristics.
- (3) Not for all pressure ranges. Please contact First Sensor if operating temperature range -40...+125 °C is required.
- (4) Storage temperature of the sensor without package.

- (5) Tested 1h, up to 85 °C. 100 % condensing or direct liquid media on high pressure port.
- (6) Proof pressure is the maximum pressure which may be applied without causing durable shifts of the electrical parameters of the sensing element.
- (7) Full Scale Span (FSS) is the algebraic difference between the output signal for the highest and lowest specified pressure.

## HMU series – basic pressure sensors

### Performance characteristics<sup>(2)</sup>

( $V_S = 5.0 V_{DC}$ ,  $T_A = 25^\circ C$ , RH=50 %, pressure applied to high pressure port)

Parameter		Min.	Typ.	Max.	Unit	
Zero pressure offset		HMUM100...	-40	0	40	mV
		all others	-30	0	30	
Temperature effects (25...85°C)	Offset	1 psi devices	-0.44	-0.22	0	%FSS/°C
		100 mbar devices	-0.30	-0.15	0	
		350 mbar / 5 psi devices	-0.20	-0.07	0	
		100 psi devices	-0.15	±0.03	0.15	
		all others	-0.10	±0.02	0.10	
	Span	100 mbar / 1 psi devices	-0.23	-0.21	-0.18	
		all others	-0.21	-0.19	-0.17	
	Bridge impedance		0.24	0.26	0.31	%/°C
Non-linearity <sup>(8)</sup>		100 mbar / 1 psi devices		±0.50	±0.90	%FSS
		all others		±0.10	±0.40	
Bridge resistance			2.8	3.3	3.8	kΩ

#### Specification notes (cont.)

- (2) Sensor is specified in air, changes in sensor behaviour based on physical effects caused by the specific media can occur. Weight of the media and wetting forces can influence the sensor characteristics.
- (8) Non-linearity is the measured deviation based on Best Fit Straight Line (BFSL).





## HMU series – basic pressure sensors

### Dimensional drawing

#### HMU...DU6... (SIL, 2 ports axial opposite side, straight big)

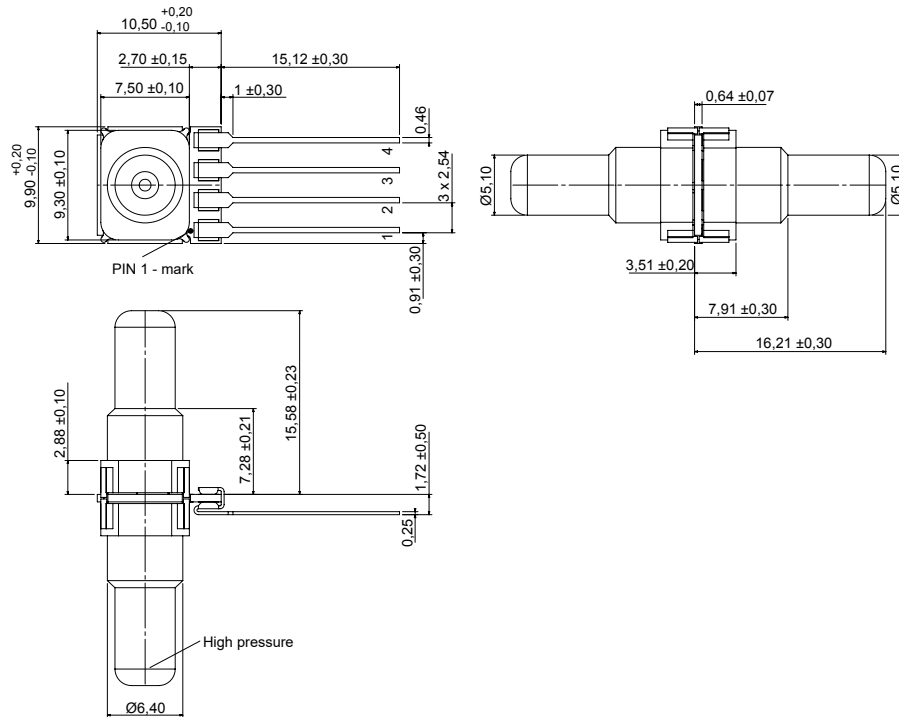

### Electrical connection

Pin	connection
1	-Vout
2	GND
3	+Vout
4	+Vs

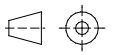

first angle projection  
dimensions in mm

#### HMU...GX6... (SIL, 1 port axial, straight big)

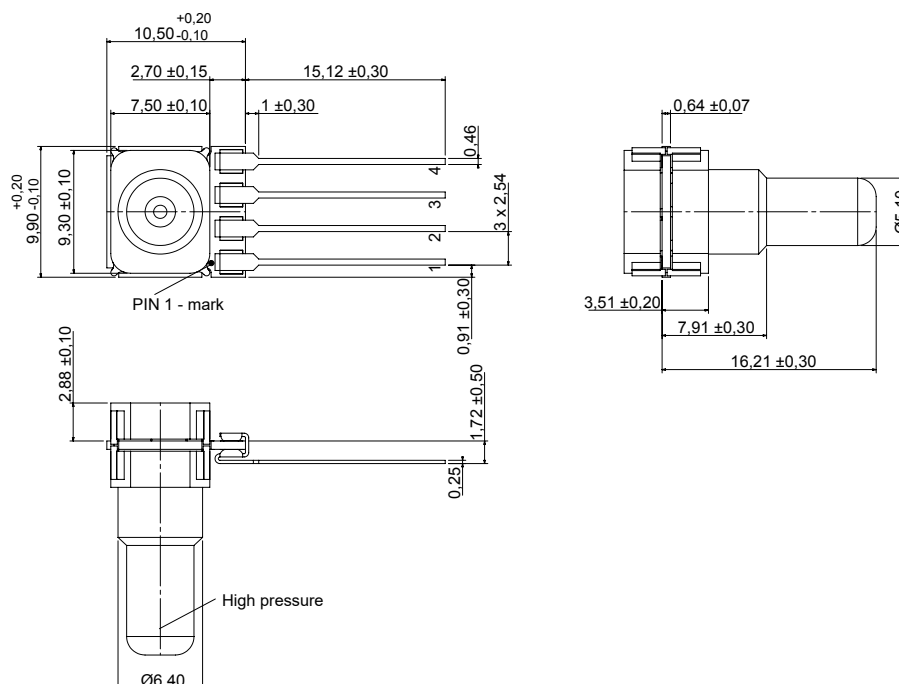

Pin	connection
1	-Vout
2	GND
3	+Vout
4	+Vs

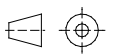

first angle projection  
dimensions in mm

## HMU series – basic pressure sensors

### Dimensional drawing

#### HMU...GZ6... (DIP, 1 port axial, straight big)

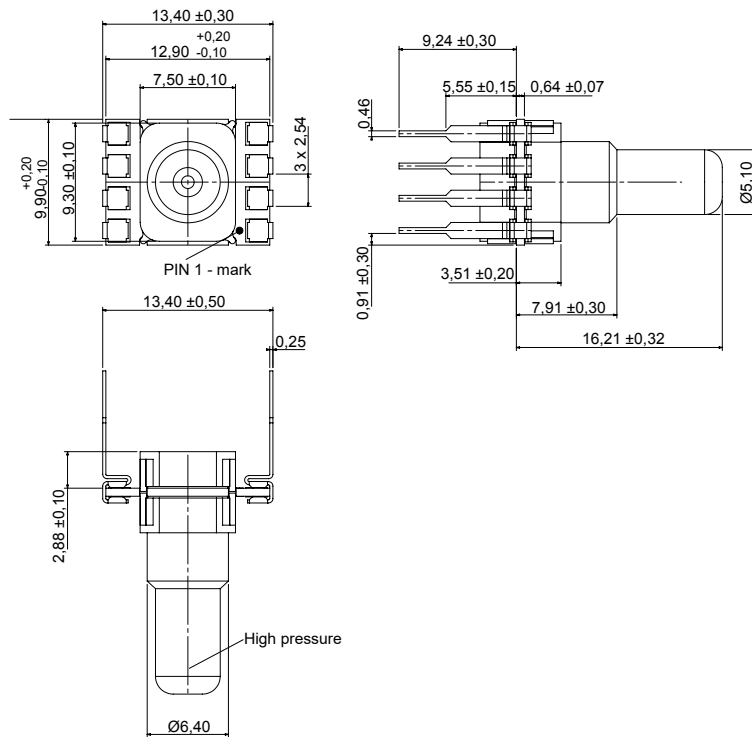

### Electrical connection

Pin	connection
1	-Vout
2	GND
3	+Vout
4	+Vs
5	GND
6	GND
7	I/C*
8	I/C*

\* internal connection. Do not connect for any reason

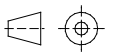

first angle projection  
dimensions in mm

#### HMU...DU5... (SIL, 2 ports axial opposite side, needle big)

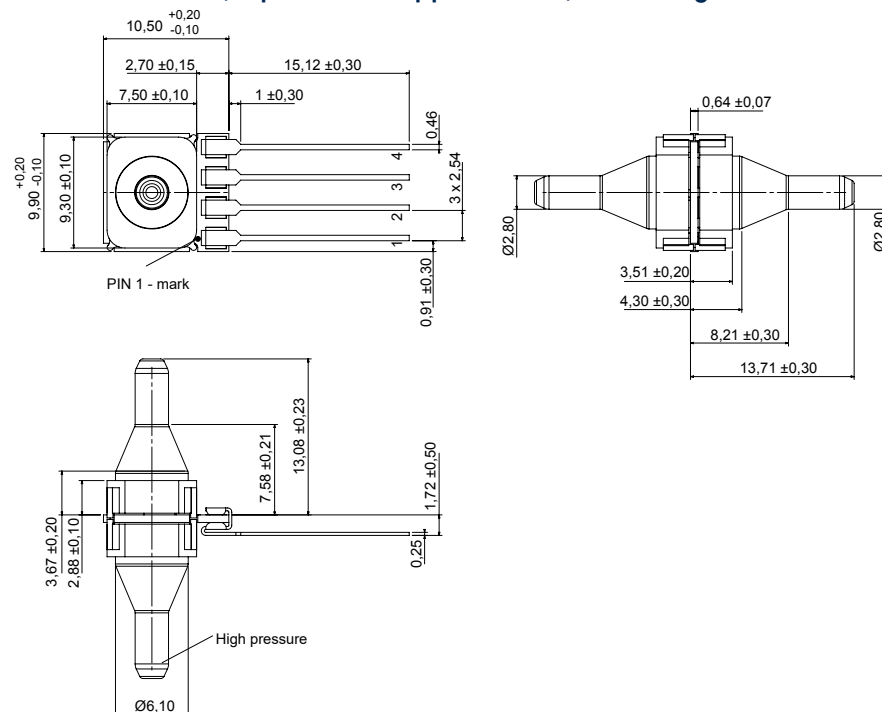

Pin	connection
1	-Vout
2	GND
3	+Vout
4	+Vs

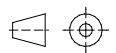

first angle projection  
dimensions in mm

## HMU series – basic pressure sensors

### Dimensional drawing

#### HMU...GX5... (SIL, 1 port axial, needle big)

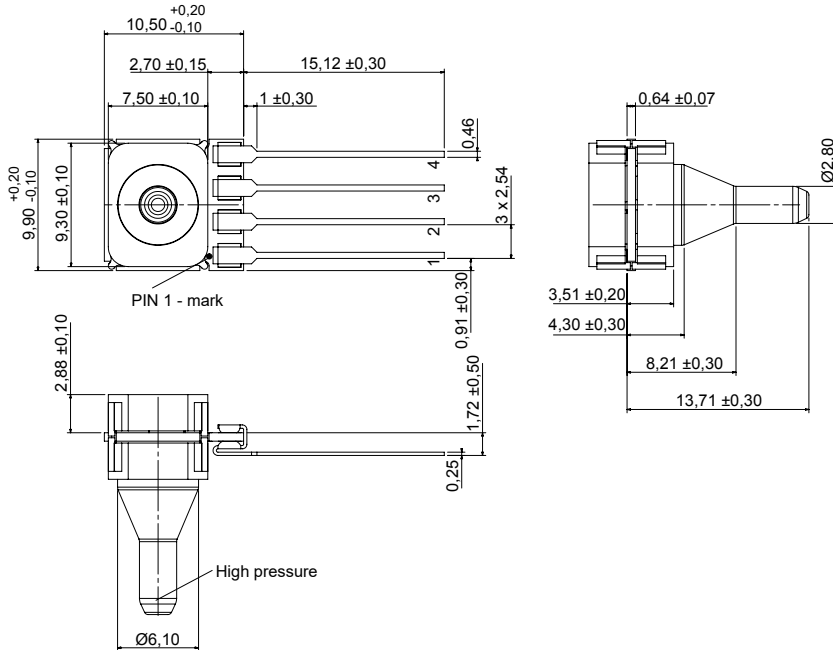

### Electrical connection

Pin	connection
1	-Vout
2	GND
3	+Vout
4	+Vs

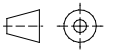

first angle projection  
dimensions in mm

#### HMU...GZ5... (DIP, 1 port axial, needle big)

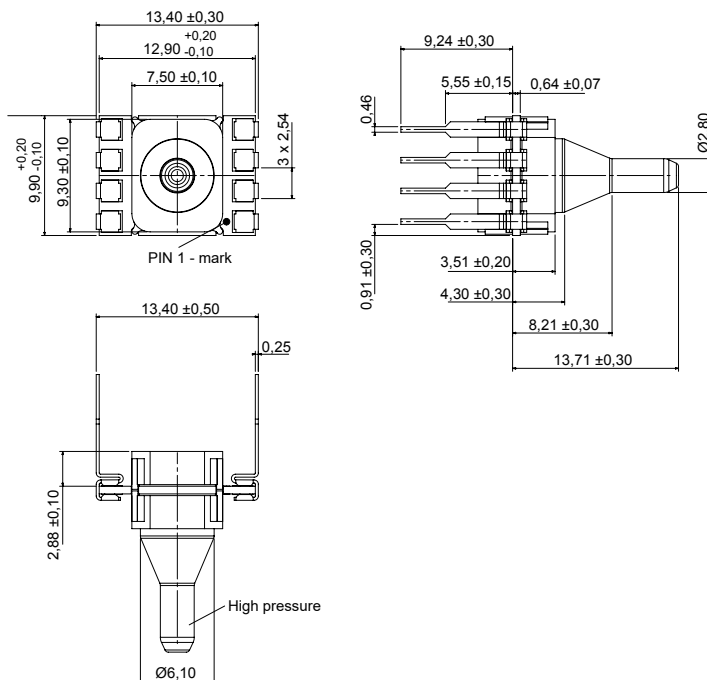

Pin	connection
1	-Vout
2	GND
3	+Vout
4	+Vs
5	GND
6	GND
7	I/C*
8	I/C*

\* internal connection. Do not connect for any reason

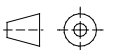

first angle projection  
dimensions in mm