

12th Gen Intel® Core™ Embedded mobile Processors

conga-HPC/cALP

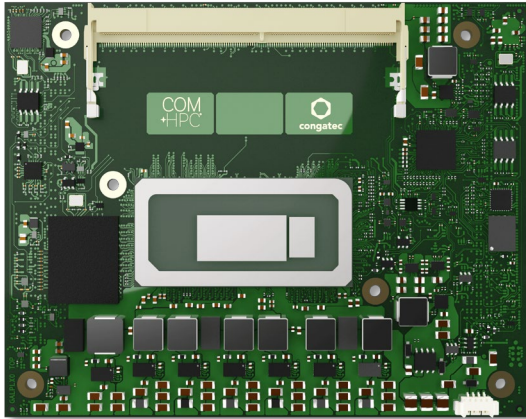

COM+HPC®

- Intel® hybrid design combines Performance-cores with Efficient-cores
- UP to Intel® Iris® Xe Graphics architecture with up to 96 EUs
- PCI Express Gen 4 | USB 4
- AI Acceleration with Intel® Deep Learning Boost (VNNI)
- Embedded Use Condition SKUs

Form factor	COM-HPC Client Size A Client Connector Pinout						
CPU	CPU	TDP Target	Cores count (P+E)	Processor Threads	P-cores Freq. GHz	E-cores Freq. GHz	Gfx Execution Units
	i7-12800HE	45W	14 (6+8)	20	2.4 / 4.6	1.8 / 3.5	96
	i5-12600HE	45W	12 (4+8)	16	2.5 / 4.5	1.8 / 3.3	80
	i3-12300HE	45W	8 (4+4)	12	1.9 / 4.3	1.5 / 3.3	48
DRAM	2 SO-DIMM sockets for DDR5 memory modules up to 32 GByte each (max. 64 GByte system capacity) up to 4800 MT/s						
Mass Storage	NVMe x1 SSD (optional)						
Graphics	Intel® UHD Graphics or Intel® Iris® Xe Graphics architecture up to 96 EUs						
Display	3x DDI (up to 8K support) eDP						
Ethernet	2x 2.5 GbE TSN Ethernet (via Intel® i225 LM)						
I/O Interfaces	Up to x8 PCIe Gen4 2 x4 PCIe Gen4 up to 8 PCIe Gen3 up to 2x Thunderbolt 2x USB 3.2 Gen2x1 8x USB2.0 up to 2x SATA 2x UART 2x MIPI-CSI 12x GPIO eSPI SM Bus I2C GSPI						
Audio	2x Soundwire fixed 2x Soundwire or HDA or I2S (opt.)						
congatec Board controller	Multi Stage Watchdog non-volatile User Data Storage Manufacturing and Board Information Board Statistics I ² C bus (fast mode, 400 kHz, multi-master) Power Loss Control Hardware Health Monitoring POST Code Redirection						
Embedded BIOS Feature	AMI Aptio® UEFI firmware 32 Mbyte serial SPI with congatec Embedded BIOS feature OEM Logo OEM CMOS default settings LCD Control Display Auto Detection Backlight Control Flash Update						
Security	Trusted Platform Module (TPM 2.0)						
Power Management	ACPI 6.0 with battery support						
Operating Systems	Microsoft® Windows 11 Microsoft® Windows 10 Microsoft® Windows 10 IoT Enterprise Linux Yocto Real Time Systems Hypervisor						
Temperature	Operating.: 0°C ... +60°C			Storage.: -20°C ... +70°C			
Humidity	Operating.: 10% ... 90% r. H. non cond.			Storage.: 5% ... 95% r. H. non cond.			
Size	120 x 95 mm						

conga-HPC/cALP | Block Diagram

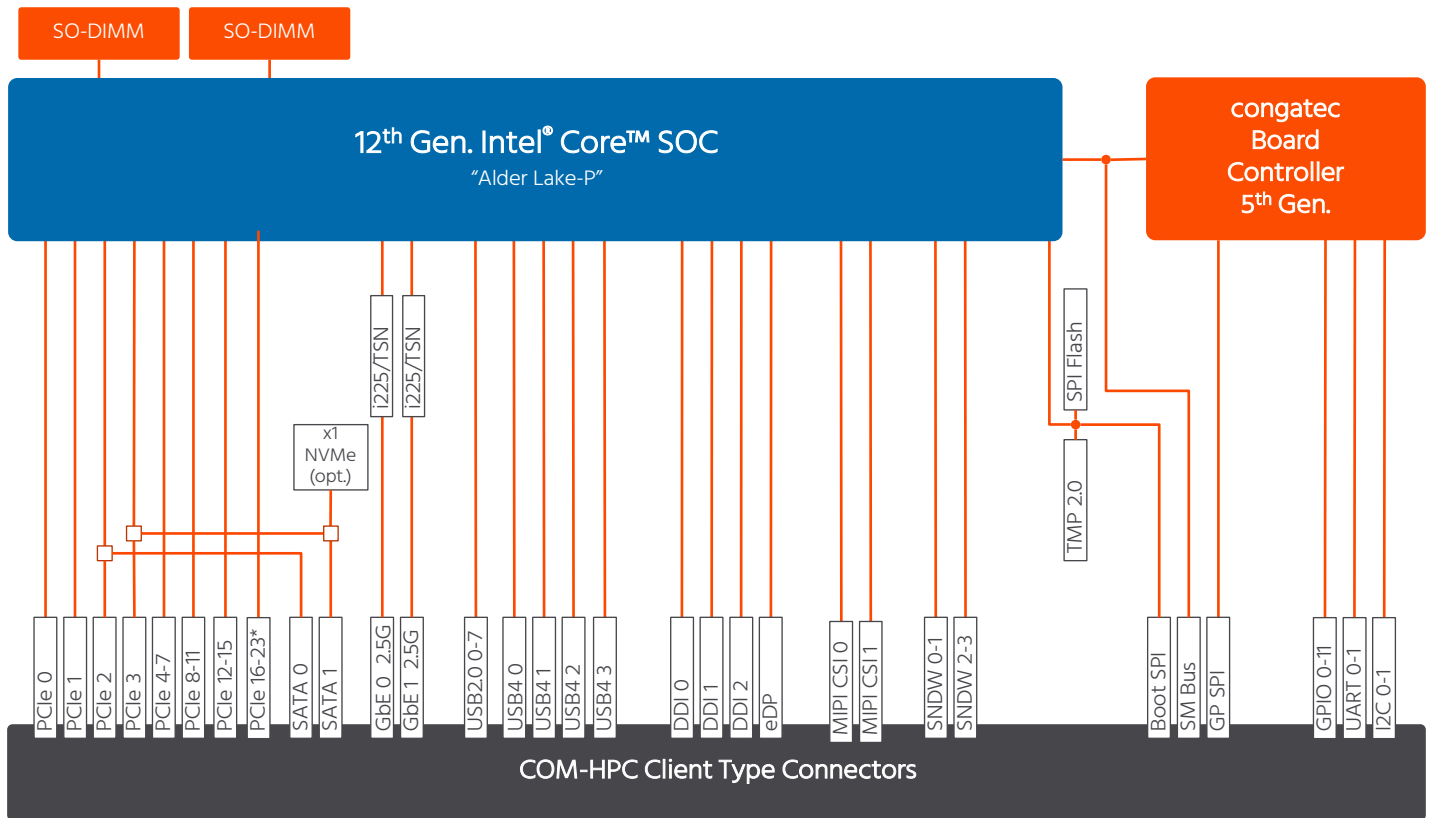

** available on selected SKUs*

conga-HPC/cALP | Bottom Side View

