

12th Gen Intel® Core™ Embedded Desktop Processors

conga-HPC/cALS

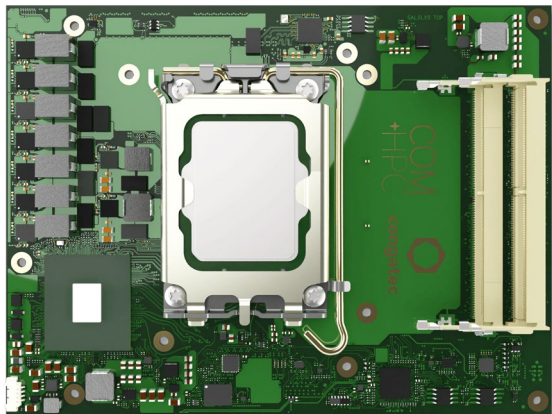

COM+HPC®

- Intel® hybrid design combines Performance-cores with Efficient-cores
- Intel® UHD Graphics 770 driven by X^e Architecture
- PCI Express Gen 4/5 | USB 3.2 Gen 2
- AI Acceleration based on Intel® Deep Learning
- Embedded Use Condition SKUs

| | | | | | | | |
|----------------------------------|---|----------------|-------------------|--------------------------------------|-------------------|-------------------|---------------------|
| Form factor | COM-HPC Client Size C Client Connector Pinout | | | | | | |
| CPUs | CPU | TDP Target (W) | Cores count (P+E) | Processor Threads | P-cores Freq. GHz | E-cores Freq. GHz | GfX Execution Units |
| | i9-12900E | 65W | 16 (8+8) | 24 | 2.3 / 5.0 | 1.7 / 3.8 | 32 EU |
| | i7-12700E | 65W | 12 (8+4) | 20 | 2.1 / 4.8 | 1.6 / 3.6 | 32 EU |
| | i5-12500E | 65W | 6 (6+0) | 12 | 2.9 / 4.5 | - / - | 32 EU |
| | i3-12100E | 60W | 4 (4+0) | 8 | 3.2 / 4.2 | - / - | 24 EU |
| Processor Socket | LGA 1700 | | | | | | |
| DRAM | 4 SO-DIMM sockets for DDR5 memory modules up to 32 GByte each (128 GByte system capacity) up to 3600 MT/s | | | | | | |
| Graphics | Intel® UHD Graphics 770 driven by X ^e Architecture up to 32 EU | | | | | | |
| Display | 3x DDI eDP | | | | | | |
| Ethernet | 2x 2.5 GbE TSN Ethernet (via Intel® i225 LM) | | | | | | |
| I/O Interfaces | 1x16 PCIe Gen 5 (PEG port) 1x4 PCIe Gen 4 2x4 PCIe Gen 3 4x USB 3.2 Gen2 8x USB2.0 2x SATA 2x UART 12x GPIO | | | | | | |
| Audio | 2x Soundwire HDA I2S (opt.) | | | | | | |
| congatec Board controller | Multi Stage Watchdog non-volatile User Data Storage Manufacturing and Board Information Board Statistics I ² C bus (fast mode, 400 kHz, multi-master) Power Loss Control Hardware Health Monitoring POST Code redirection | | | | | | |
| Embedded BIOS Feature | AMI Aptio® UEFI firmware 32 Mbyte serial SPI with congatec Embedded BIOS feature OEM Logo OEM CMOS default settings LCD Control Display Auto Detection Backlight Control Flash Update | | | | | | |
| Security | Trusted Platform Module (TPM 2.0) | | | | | | |
| Power Management | ACPI 6.0 with battery support | | | | | | |
| Operating Systems | Microsoft® Windows 11 Microsoft® Windows 10 Microsoft® Windows 10 IoT Enterprise Linux Yocto Real Time Systems Hypervisor | | | | | | |
| Temperature | Operating Temp.: 0°C ... +60°C | | | Storage Temp.: -20°C ... +70°C | | | |
| Humidity | Operating.: 10% ... 90% r. H. non cond. | | | Storage.: 5% ... 95% r. H. non cond. | | | |
| Size | 120 x 160 mm | | | | | | |

conga-HPC/cALS | Block Diagram

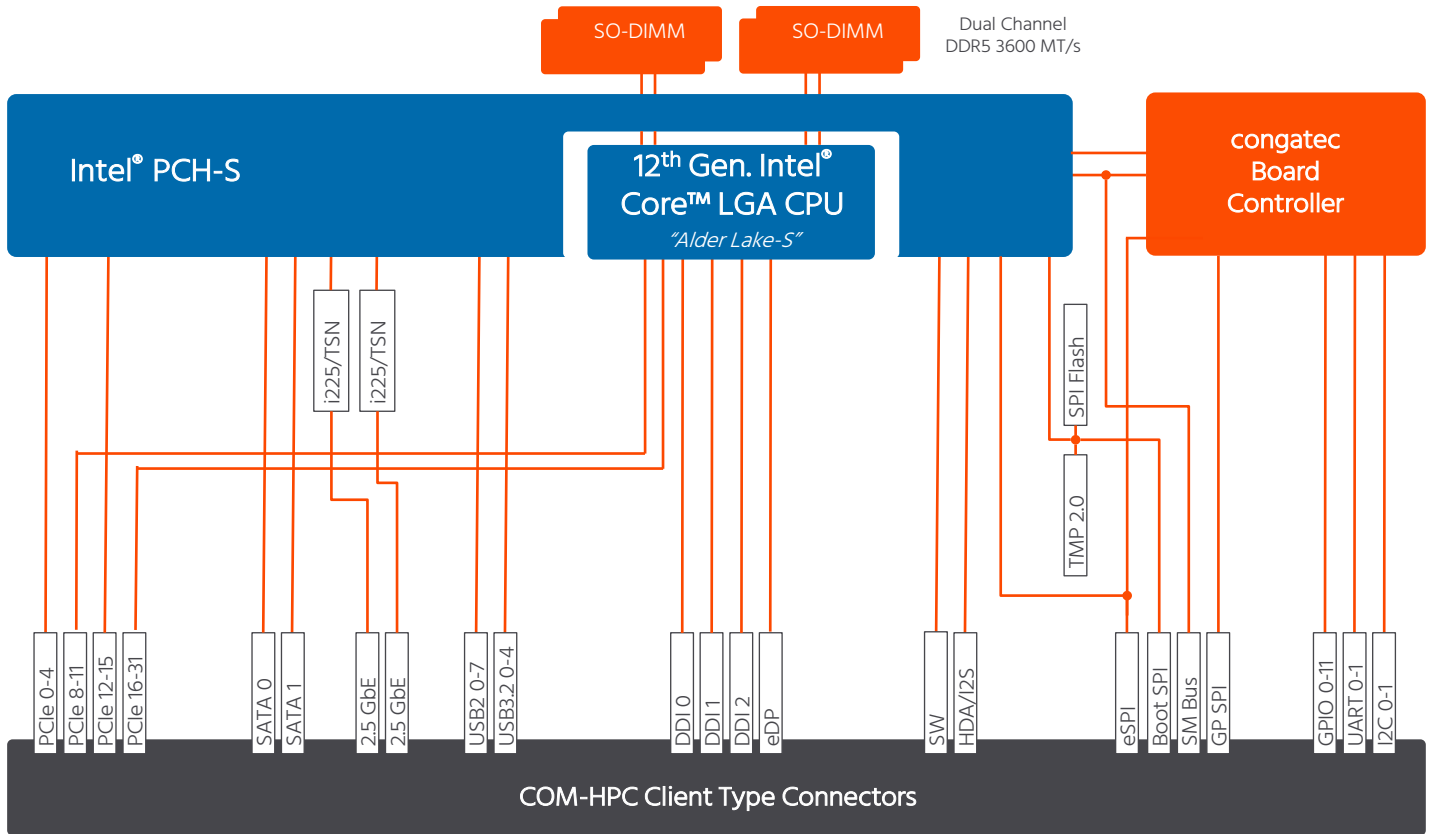

conga-HPC/cALS | Bottom Side View

