

# HR2220P601R-10

## PHYSICAL DIMENSIONS:

A	5.59 [.220]	+ 0.51 [.020]
B	5.08 [.200]	+ 0.25 [.010]
C	3.05 [.120]	+ 0.25 [.010]
D	0.76 [.030]	+ 0.25 [.010]

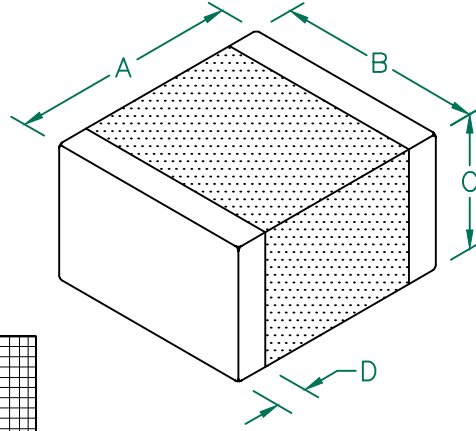

## ELECTRICAL CHARACTERISTICS:

Z @ 100MHz (Ω)	DCR (Ω)	Rated Current
Nominal	600	
Minimum	450	
Maximum	750	0.025 4000 mA

NOTES: UNLESS OTHERWISE SPECIFIED

1. TAPED AND REELED per CURRENT EIA SPECIFICATIONS 13" REELS, 2,000 PCS/REEL.
2. U.S. PATENTS 5,821,846, 6,107,907, AND 6,249,205B1 ARE APPLIED
3. TERMINATION FINISH IS 100% TIN.
4. COMPONENTS SHOULD BE ADEQUATELY PREHEATED BEFORE SOLDERING.
5. OPERATING TEMPERATURE TEMP: -40°C~+125°C (INCLUDING SELF-HEATING)
6. COSMETIC SPECIFICATION REFER TO WI-QA-124.

Z vs FREQUENCY  
IMPEDANCE UNDER DC BIAS

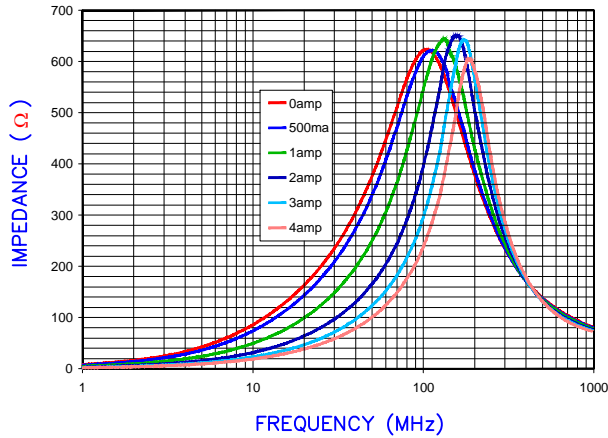

|Z|, R, AND X vs. FREQUENCY

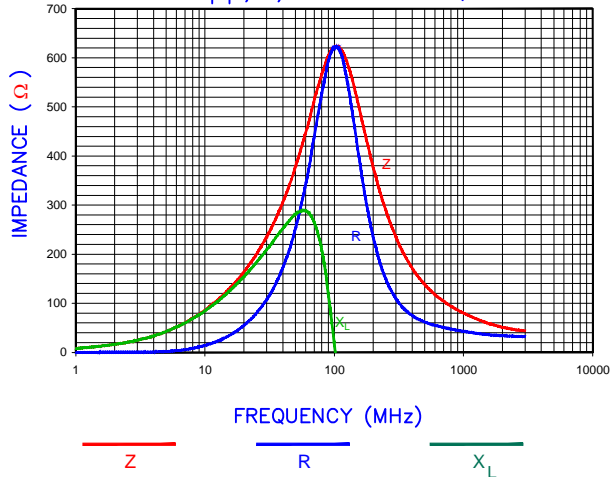

## LAND PATTERNS FOR REFLOW SOLDERING

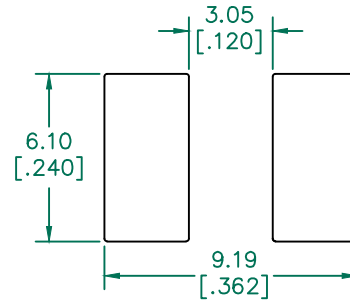

(For wave soldering, add 0.762 [.030] to this dimension.)

## RECOMMENDED SOLDERING CONDITIONS

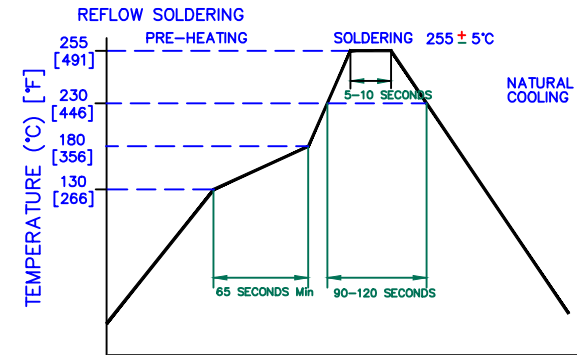

DIMENSIONS ARE IN mm [INCHES].

This print is the property of Laird Tech. and is loaned in confidence subject to return upon request and with the understanding that no copies shall be made without the written consent of Laird Tech. All rights to design or invention are reserved.



AGILENT E4991A RF Impedance/Material Analyzer  
AGILENT 16194A Test Fixture. TEST REF. 3298

D	UPDATE NOTES 2	05/18/15	QU	PROJECT/PART NUMBER:	REV	PART TYPE:	DRAWN BY:
C	ADD OPERATING TEMPERATURE UPDATE LAIRD LOGO AND REFLOW CURVE	08/05/13	QU	HR2220P601R-10	D	CO-FIRE	QU
B	UPDATE COMPANY LOGO ADD ROHS	02/14/08	JRK	DATE:	08/05/13	SCALE:	NTS
A	ORIGINAL DRAFT	04/03/04	TMB	CAD #		TOOL #	
REV	DESCRIPTION	DATE	INT	HR2220P601R-10-D			1 of 1