

DRAWING FOR REFERENCE: This is subject to change without notice  
08/11/2012

CABLE ASSEMBLE TOOL

LOCATOR : HRMM-T-2  
FOR PRESS FITTING OF DISK : P06-T-2

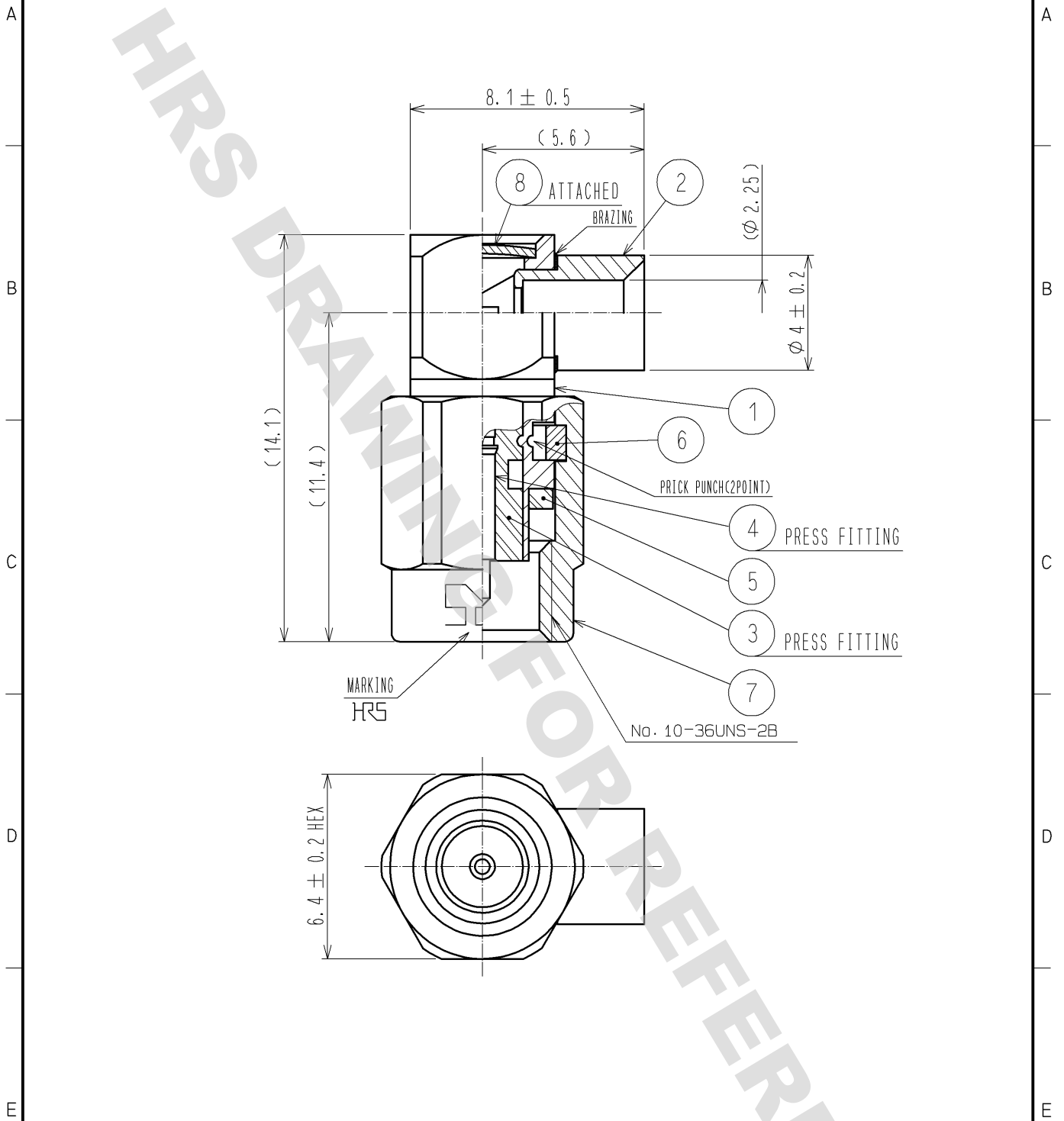

RoHS COMPLIANT

4	BRASS	GOLD PLATING	8	BRASS	GOLD PLATING
3	PTFE		7	STAINLESS STEEL	GOLD PLATING
2	STAINLESS STEEL	GOLD PLATING	6	BERYLLIUM COPPER	NICKEL PLATING
1	STAINLESS STEEL	GOLD PLATING	5	SILICONE RUBBER	(RED)
NO.	MATERIAL	FINISH . REMARKS	NO.	MATERIAL	FINISH . REMARKS

UNITS mm	SCALE 5 : 1	COUNT	DESCRIPTION OF REVISIONS	DESIGNED	CHECKED	DATE
<b>HRS</b> HIROSE ELECTRIC CO., LTD.			APPROVED : MH. YAMANE 11. 01. 13 CHECKED : TS. NOBE 11. 01. 12 DESIGNED : YI. FUNADA 11. 01. 11 DRAWN : YI. FUNADA 11. 01. 11	DRAWING NO. EDC4-135414-40 PART NO. HRMM-104-A(40) CODE NO. CL333-0057-3-40		