

# HRPS

## Hall-Effect Rotary Position Sensor with integrated connector



### DESCRIPTION

The HRPS Series of Hall-effect Rotary Position Sensors is a cost-effective, non-contacting position sensing solution for applications in harsh environments such as transportation and industrial.

This compact sensor with integrated AMP superseal connector uses a permanent magnet that is securely fastened to the shaft and acts as the only moving component in the sensor.

Fully sealed and flanged mounted for easy positioning, the sensor is versatile with configurable angular ranges from 50 to 360 degrees, different pin-out options and support for low and high-voltage power supply.

### KEY FEATURES



#### True, contactless operation

Without any gears or mechanical interfaces the sensor is easily assembled and calibrated and subject to limited wear and tear over lifetime.

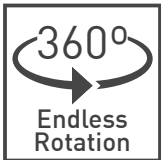

#### 360 degree absolute position feedback

Endless mechanical rotational angle without dead band, keeps the position on power loss with configurable electrical angles from 50 to 360 degrees.



#### Made for harsh environments

The rugged package protects the sensor from dust, moisture, vibration and extreme temperatures for usage in the most demanding environments.



#### Durable and robust design

The non-contacting design allows for an extra-long product lifetime of up to 50 million cycles.

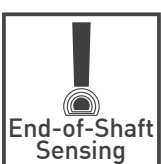

#### Integrated shaft

The magnet is securely fastened to the shaft and acts as only moving component in the sensor.

### APPLICATIONS

#### Industrial

- ▶ Warehouse automatic guided vehicles
- ▶ Valve monitoring
- ▶ HVAC systems

#### Heavy-duty transportation vehicles

- ▶ Steering wheel angle
- ▶ Pedal position for off-road vehicles
- ▶ Suspension/height detection
- ▶ Fork height and mast tilt
- ▶ Bucket position
- ▶ Hitch position
- ▶ Transmission gear shift

# HRPS

## Hall-Effect Rotary Position Sensor with integrated connector

### MECHANICAL SPECIFICATIONS

Rotational life	Up to 50 M cycles
Mechanical range	360° (endless rotation)
Mating connector	AMP Superseal 282087-1
Mounting screw sizes	
Sensor to mounting surface	non-magnetic, stainless steel M5 screws and 10 mm OD washers
Lever to mounting surface	non-magnetic stainless steel M6 screws

### ELECTRICAL SPECIFICATIONS

Output Protocol	Analog (Ratiometric)	
Supply voltage	5V ±10%	7V to 32V
Supply current	12 mA	14 mA
Overvoltage protection	+10V	+36V
Reverse voltage protection	-10V	-30V
Output		
standard	10% to 90% Vdc (CW)	
inverted	90% to 10% Vdc (CCW)	
Absolute linearity / Accuracy error <sup>1</sup>	± 1% (± 0,5% upon request)	
Resolution	Up to 12 bit	
Self-diagnostic features	yes	

<sup>1</sup> Ferromagnetic materials close to the sensor (i.e. shaft, mounting surface) may affect the sensor's linearity.

### ENVIRONMENTAL SPECIFICATIONS

Operating temperature	-40° to +125°C
Shock	50g
Vibration	5-2000 Hz; 20g; Amax 0,75 mm
Sealing	IP67, IP69K

# HRPS

## Hall-Effect Rotary Position Sensor with integrated connector

### DIMENSIONS (MM)

#### HRPS-F (w/o lever)



Download the STEP file here:  
[www.pihher.net](http://www.pihher.net)

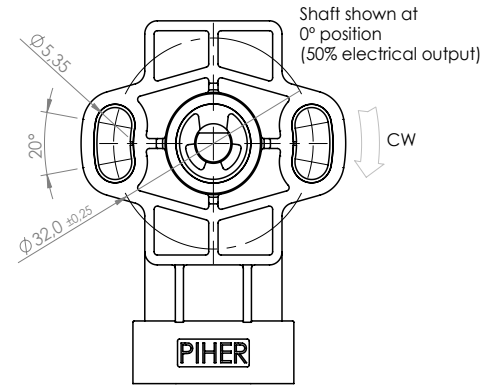
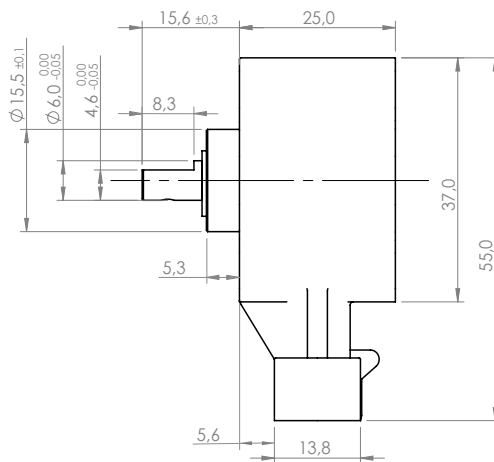
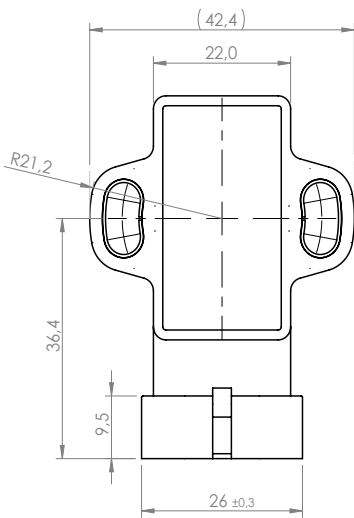
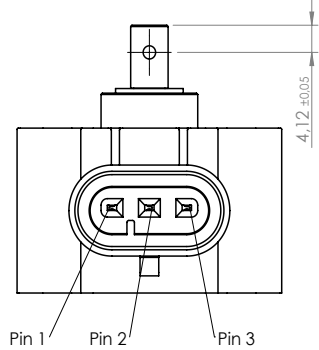
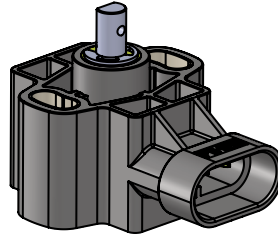

#### HRPS-H (with lever)

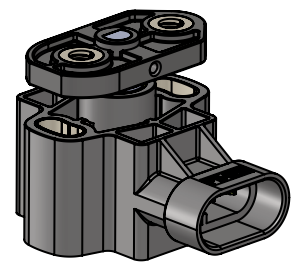
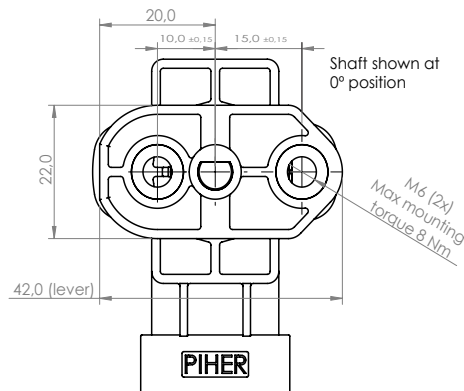
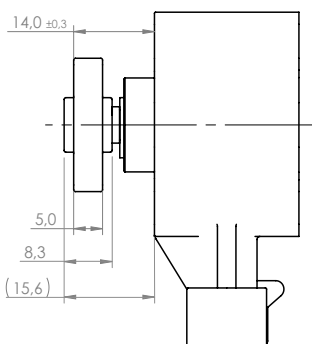

### CONNECTION SCHEME

PIN	European Pinout	American Pinout
1	Ground	Power supply
2	Power supply	Ground
3	Signal output	Signal output