



Thin Film Platinum RTDs
HRTS Series



Thin Film Platinum RTDs

The HRTS Series Thin Film Platinum RTDs (Resistance Temperature Detectors) are designed to measure temperatures from -70 °C to 260 °C [-94 °F to 500 °F]. These fully-assembled elements are ready to use in probe assemblies without the need for fragile splices to extension leads.

These products are manufactured using a thin layer of platinum deposited on an alumina substrate and are laser trimmed to a resistance interchangeability of a standard $\pm 0.2\%$ (± 0.5 °C accuracy) or an optional $\pm 0.1\%$ (± 0.3 °C accuracy). The sensor chip is then glassed, wired and potted to result in an alumina package with Teflon®-insulated lead wires.

Key Features

- Linear resistance vs temperature
- Interchangeable resistance
- Accurate
- Fast response
- Laser trimmed
- Ceramic case material
- TFE Teflon® lead wires
- Ready-to-use, fully-assembled elements

Potential Applications

Temperature sensing for monitoring, compensation and regulation in:

INDUSTRIAL

- HVAC equipment
- Instrument and probe assemblies
- Process control for temperature regulation
- Motor windings and bearings
- Battery packs
- Environmental chambers

MEDICAL

- Autoclaves

AEROSPACE AND DEFENSE

- Aircraft
- Space vehicles
- Satellites
- Rovers

Thin Film Platinum RTDs, HRTS Series

Table 1. Specifications

Characteristic	Condition	Parameter
Alpha: R ₀ = 1000 Ω R ₀ = 100 Ω	0 °C	0.00375 Ω/Ω/°C 0.00385 Ω/Ω/°C
Temperature range:	—	-70 °C to 260 °C [-94 °F to 500 °F]
Temperature accuracy: R ₀ ±0.2% trim (standard) R ₀ ±0.1% trim (optional)	—	±0.5 °C or 0.8% of temperature, whichever is greater ±0.3 °C or 0.6% of temperature, whichever is greater
Time constant, 1/e	metal surfaces	0.6 s typ.
Operating current	—	2 mA max. for self heating errors of 1 °C; 1 mA recommended
Self heating	—	0.3 mW/°C
Construction material: case leads	—	alumina nickel-coated stranded copper, Teflon® insulated

Table 2. Constant Values (β = 0 and C = 0 for T > 0 °C)

Constant	1000 Ω	100 Ω	Functional Behavior
Alpha α (°C ⁻¹)	0.00375 ±0.000029	0.003850 ±0.000010	$R_T = R_0(1 + AT + BT^2 - 100CT^3 + CT^4)$ Where: R _T = Resistance (Ω) at temperature T (°C) R ₀ = Resistance (Ω) at 0 °C T = Temperature (°C) $A = \alpha + \frac{\alpha\delta}{100}$ $B = -\frac{\alpha\delta}{100^2}$ $C_{T=0} = -\frac{\alpha\beta}{100^4}$
Delta δ (°C)	1.605 ±0.009	1.4999 ±0.007	
Beta β (°C)	0.16	0.10863	
A (°C ⁻¹)	3.81 x 10 ⁻³	3.908 x 10 ⁻³	
B (°C ⁻²)	-6.02 x 10 ⁻⁷	-5.775 x 10 ⁻⁷	
C (°C ⁻⁴)	-6.0 x 10 ⁻¹²	-4.183 x 10 ⁻¹²	

Table 3. Accuracy vs Temperature

Temperature (°C)	Tolerance			
	Standard Trim (±0.2%)		Optional Trim (±0.1%)	
	±ΔR ¹ (Ω)	±ΔT (°C)	±ΔR ¹ (Ω)	±ΔT (°C)
-100	2.9	0.8	2.4	0.6
0	2.0	0.5	1.0	0.3
100	2.9	0.8	2.2	0.6
200	5.6	1.6	4.3	1.2
300	8.2	2.4	6.2	1.8
400	11.0	3.2	8.3	2.5
500	12.5	4.0	9.6	3.0
600	15.1	4.8	10.4	3.3

¹1000 Ω RTD. Divide Δ by 10 for 100 Ω RTD.

Thin Film Platinum RTDs, HRTS Series

Figure 1. Resistance vs Temperature

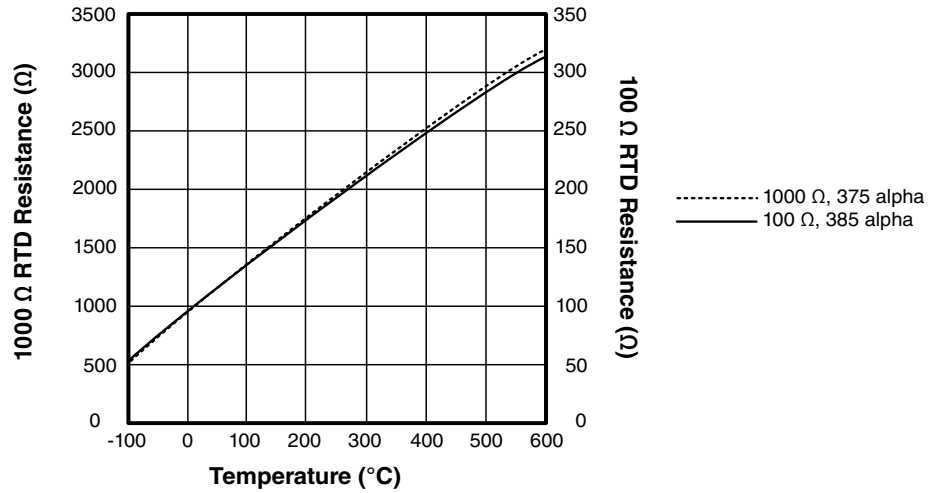
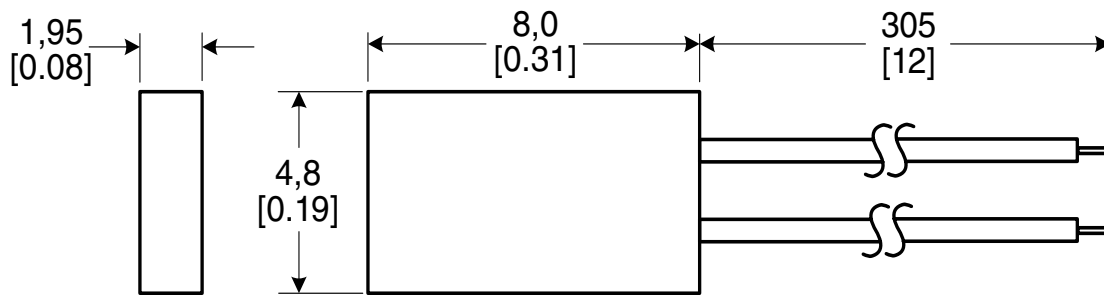

Figure 2. Mounting Dimensions (For reference only. mm/[in].)



CAUTION PRODUCT DAMAGE

- Ensure proper ESD (Electrostatic Discharge) precautions are followed when handling this product.

Failure to comply with these instructions may result in product damage.

Table 4. Order Guide

Catalog Listing	Description
HRTS-5760-B-T-0-12	HRTS Series platinum thin film RTD with two, 28 gauge TFE Teflon [®] -insulated leadwires, a resistance and alpha of 100 Ω: 0.00385 Ω/Ω/°C, a standard ±0.2% trim resistance, and 305 mm [12 in] leadwires
HRTS-5760-B-T-1-12	HRTS Series platinum thin film RTD with two, 28 gauge TFE Teflon [®] -insulated leadwires, a resistance and alpha of 100 Ω: 0.00385 Ω/Ω/°C, an optional ±0.1% trim resistance, and 305 mm [12 in] leadwires
HRTS-5760-B-U-0-12	HRTS Series platinum thin film RTD with two, 28 gauge TFE Teflon [®] -insulated leadwires, a resistance and alpha of 1000 Ω: 0.00375 Ω/Ω/°C, a standard ±0.2% trim resistance, and 305 mm [12 in] leadwires
HRTS-5760-B-U-1-12	HRTS Series platinum thin film RTD with two, 28 gauge TFE Teflon [®] -insulated leadwires, a resistance and alpha of 1000 Ω: 0.00375 Ω/Ω/°C, an optional ±0.1% trim resistance, and 305 mm [12 in] leadwires

Thin Film Platinum RTDs, HRTS Series

Figure 3. Circuits

Wheatstone Bridge 2-Wire Interface

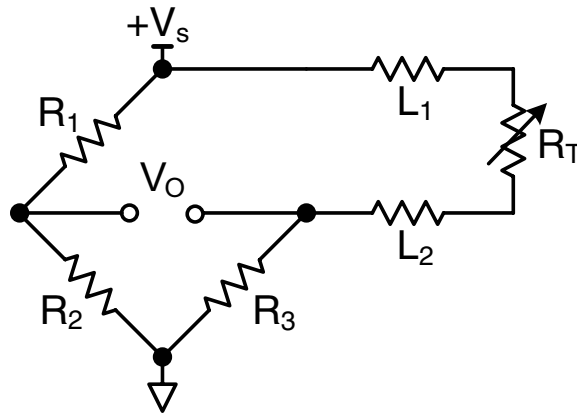

Linear Output Voltage

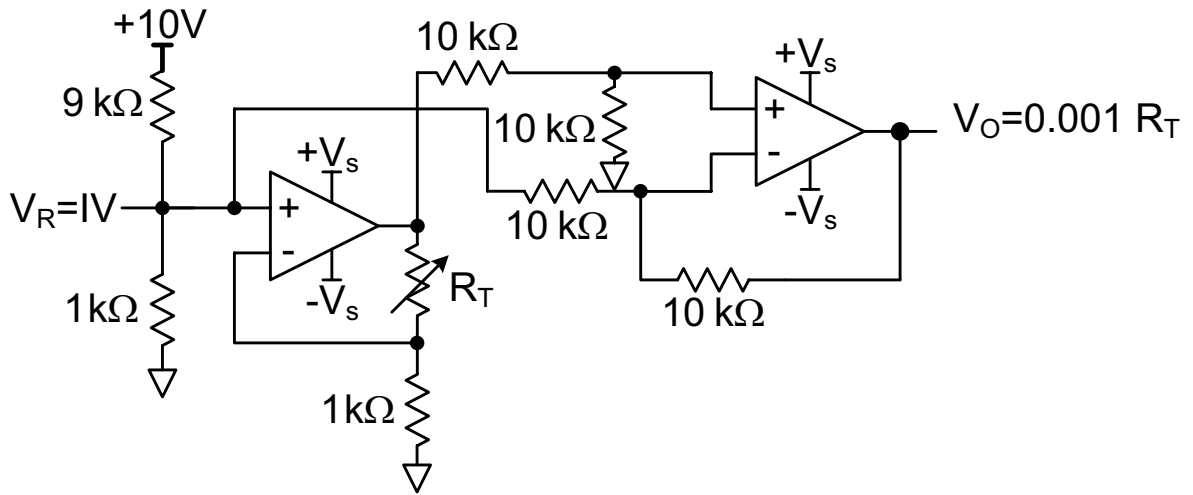

Adjustable Point (Comparator) Interface

