

# 3M™ MetPak™ HSHM Press-Fit Header

2 mm Type D, 176 Signal Contacts, 8 Rows, Straight

HSHM Series

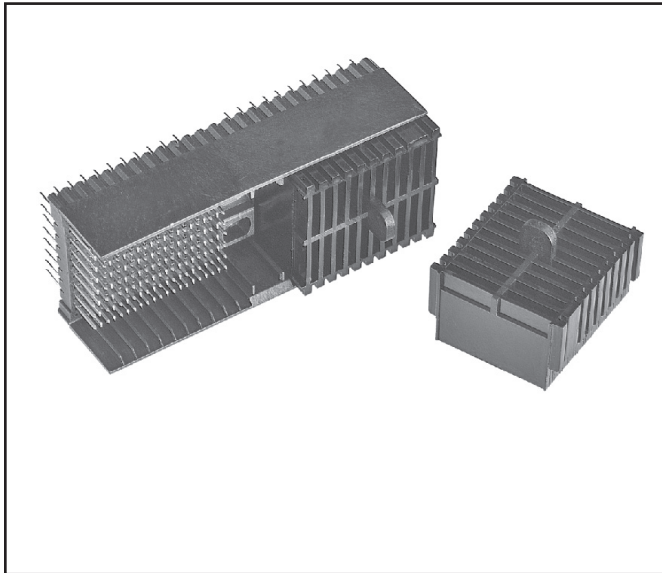

- Up to 5 Gb/s data rates
- Low crosstalk at high frequencies
- 50/100  $\Omega$  (single-ended /differential) impedance
- Modular/scalable format IEC 61076-4-101
- 101 mated lines per linear inch
- Four integrated 8.25 A power contacts
- Integrated guide pin
- End-to-end stackable with 8 row 3M™ MetPak™ HM and HSHM headers
- See the Regulatory Information Appendix (RIA) in the “RoHS compliance” section of [www.3mconnector.com](http://www.3mconnector.com) for compliance information

Date Modified: November 8, 2010

TS-2015-B  
Sheet 1 of 3

## Physical

### Insulation:

Material: High Temperature Thermoplastic (LCP)  
Flammability: UL 94V-0

### Contact:

Material: Copper Alloy  
Plating: See Ordering Information

## Performance

### Mechanical:

Normal Force (Nominal): 0.57 N [58 g] Signal, 0.74 N [75 g] Shield  
Engagement Force (Nominal): 0.32 N [33 g] Signal, 0.22 N [22 g] Shield  
Separation Force (Nominal): 0.20 N [20 g] Signal, 0.20 N [20 g] Shield  
Wipe (Nominal, Shortest Contact): 2.67 mm [0.105 in] Signal, 1.57 mm [0.062 in] Shield  
Mate/Unmate Cycles: 250  
Application: This module is suitable for stand-alone use. (Refer to IEC-61076-4-101)

### Electrical:

Data Rate: 5 Gb/s  
Characteristic Impedance: 50  $\Omega$  Single-ended, 100  $\Omega$  Differential  
Current Rating (Fully Loaded): 1 A @ 70° C Signal  
Insulation Resistance: 10<sup>4</sup> M $\Omega$  @ 100 V<sub>DC</sub>  
Withstanding Voltage: 750 V<sub>rms</sub>

## Environmental

**Temperature Rating:** -55° C to 125° C

UL File No.: E68080

MetPak is a trademark of 3M Company.

# 3M™ MetPak™ HSHM Press-Fit Header

2 mm Type D, 176 Signal Contacts, 8 Rows, Straight

HSHM Series

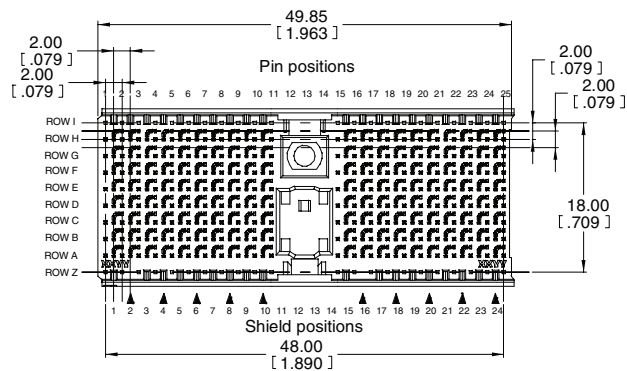

▲ denotes shield column (tail only) omitted for the row differential pair part

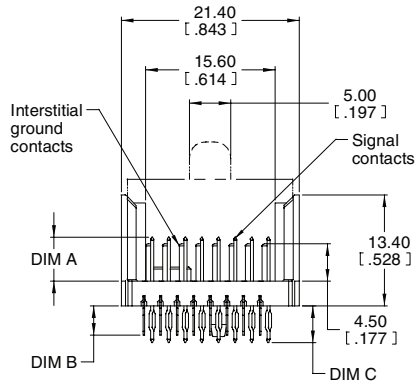

DIM A = Pin mating length  
DIM B = Shield tail length  
DIM C = Pin tail length

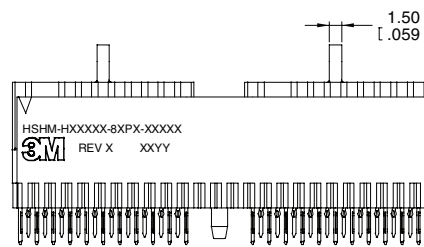

Coaxial, column differential and stripline configuration shown with protective caps\*

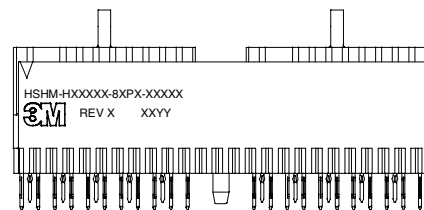

Row differential configuration shown with protective caps\*

\* Caps to be removed after press-fit installation process

mm (Inch)		
Tolerance Unless Noted		
	0	0.0
mm	±3	±0.3 ±0.13

( ) Dimensions used for Reference Only

## Ordering Information

**HSHM-H176DPWRX-8CPX-XXXXX** (rows I and Z not loaded)

High Speed Option:

- 4 = Coaxial, column differential and stripline (75 Ω) applications
- 5 = Row differential applications

Tail Length:

- 1 = 4.4 mm pin and 3.5 mm shield
- 2 = 2 mm pin and 2 mm shield

Plating μm [μ"]:

TG30 = 0.76 [30] Min. Au Contact Area  
2.54 [100] Min. SnPb Terminal Area (RIA C2 & E2 apply)  
1.27 [50] Min. Ni All over  
Standard Option

TG30L = 0.76 [30] Min. Au Contact Area, Lubricated  
2.54 [100] Min. SnPb Terminal Area (RIA C2 & E2 apply)  
1.27 [50] Min. Ni All over  
Non-Standard Option (Available with longer lead times and higher make order quantities, MOQ)

TG50 = 1.27 [50] Min. Au Contact Area, Lubricated  
2.54 [100] Min. SnPb Terminal Area (RIA C2 & E2 apply)  
1.27 [50] Min. Ni All over  
Non-Standard Option (Available with longer lead times and higher make order quantities, MOQ)

Standard Configuration

DIM A = 5.3 mm for rows A through H

For non-standard configurations contact sales representative

TS-2015-B  
Sheet 2 of 3

# 3M™ MetPak™ HSHM Press-Fit Header

2 mm Type D, 176 Signal Contacts, 8 Rows, Straight

HSHM Series

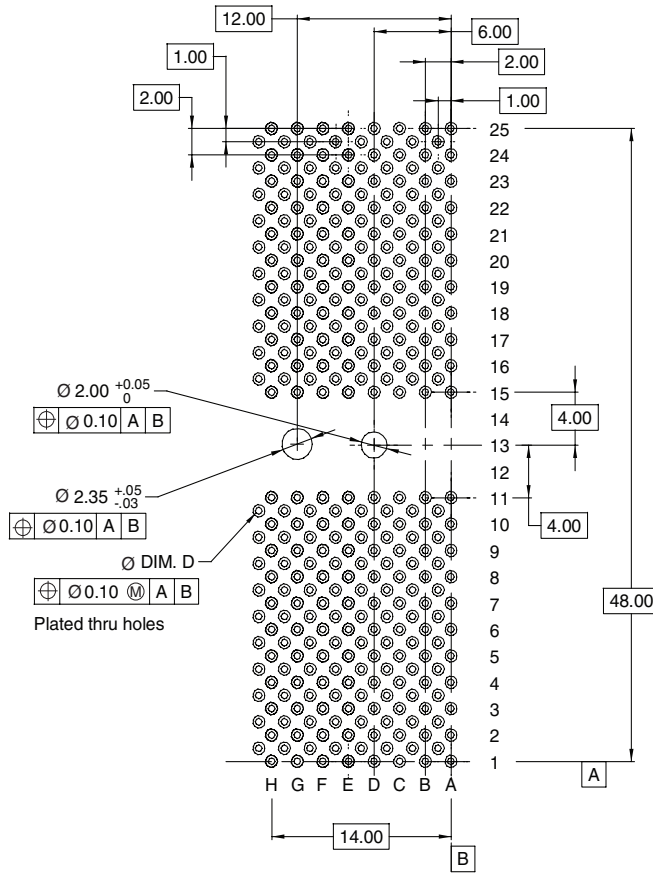

Recommended PCB hole mounting pattern for coaxial, column differential and stripline applications

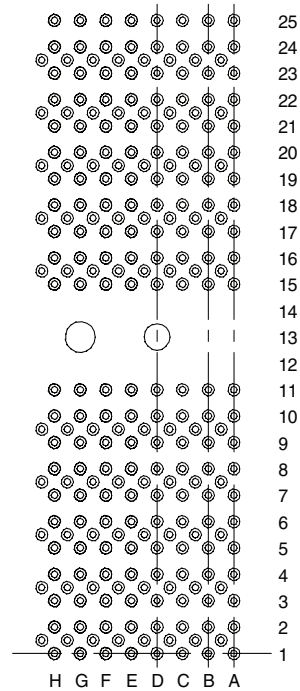

Recommended PCB hole mounting pattern for row differential applications

(Same geometry as left view without the ground vias)

Hole Plating Table mm			
Finished Hole Dia.	Cu. Thickness	SnPb Thickness	Drilled Hole Dia.
0.457 - 0.559 [.0180 - .0220]	0.025 - 0.045 [.0010 - .0018]	0.008 - 0.018 [.0003 - .0007]	0.584 - 0.625 [.0230 - .0246]

TS-2015-B  
Sheet 3 of 3