



8 Amp Schottky Barrier Rectifier

DESCRIPTION

The HSM880, HSM890, and HSM8100 series provides 8 Amp, 80V-100V Schottky surface mount rectifier in either J lead or gull wing configuration with low forward voltage and low leakage current. For critical applications requiring very fast switching, these higher voltage Schottkys with their “hot carrier” features provide extremely fast switching to replace conventional ultrafast rectifiers.

Important: For the latest information, visit our website <http://www.microsemi.com>.

FEATURES

- Schottky Barrier Rectifier
- Guard Ring Protection
- 175°C Junction Temperature
- High Current Capability
- V_{RWM} 80 to 100 Volts
- Surface Mount Packages
- Low profile surface mount package
- RoHS compliant versions are available with e3 suffix

APPLICATIONS / BENEFITS

- Silicon Schottky (hot carrier) rectifier for minimal t_{rr} and elimination of reverse-recovery oscillations to reduce need for EMI filtering
- For use in high-frequency switching power supplies, inverters, free wheeling, polarity protection, and “ORing” applications
- Low power loss and high efficiency
- Low profile package
- Robust package configuration for pick-and-place handling

MAXIMUM RATINGS @ 25 °C unless otherwise noted

Parameters/Test Conditions	Symbol	Value	Unit
Storage Temperature	T_{STG}	-55 to +175	°C
Junction Temperature	T_J	-55 to +175	°C
Thermal Resistance Junction-to-Ambient ⁽¹⁾	$R_{\theta JA}$	75	°C/W
Thermal Resistance Junction-to-Case	$R_{\theta JL}$	20	°C/W
Forward Surge Current ⁽²⁾	I_{FSM}	300	A
Average Rectified Forward Current @ $T_L = 75$ °C (Square wave)	$I_{F(AV)}$	8.0	A
Solder Temperature @ 10 s		260	°C

- Notes:** 1. On PCB with FR4 using 2 oz copper and recommended mounting pad size (see [pad layout](#)).
2. At 8.3 ms single half-sine waveform superimposed on rated load (JEDEC method).

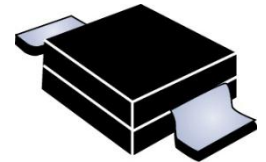

**DO-215AB
(SMCG) Package**



**DO-214AB
(SMCJ) Package**

NOTE: All SMC series are equivalent to prior SMM package identifications.

MSC – Lawrence

6 Lake Street,
Lawrence, MA 01841
1-800-446-1158 or
(978) 620-2600
Fax: (978) 689-0803

MSC – Ireland

Gort Road Business Park,
Ennis, Co. Clare, Ireland
Tel: +353 (0) 65 6840044
Fax: +353 (0) 65 6822298

Website:

www.microsemi.com

MECHANICAL and PACKAGING

- CASE: Void-free transfer molded thermosetting epoxy body meeting UL94V-0.
- TERMINALS: RoHS compliant annealed matte-tin plating. Readily solderable per MIL-STD-750, method 2026.
- POLARITY: Indicated by cathode band
- TAPE-AND-REEL: Standard per EIA-481-B (add "TR" suffix to part number). Consult factory for quantities.
- WEIGHT: Approximately 0.22 grams
- See [Package Dimensions](#) on last page.

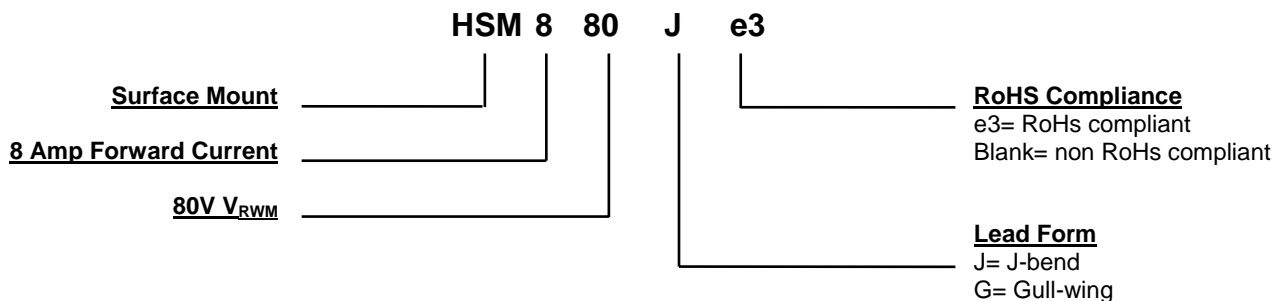
PART NOMENCLATURE

SYMBOLS & DEFINITIONS

Symbol	Definition
C_T	Total Capacitance: The total small signal capacitance between the diode terminals of a complete device.
I_F	Forward Current: The forward current dc value, no alternating component.
I_{FSM}	Maximum Forward Surge Current: The forward current, surge peak or rated forward surge current.
$I_{F(AV)}$	Average Rectified Forward Current: The current averaged over a full cycle with 180 degree conduction angle (square wave).
I_R	Reverse Current: The maximum reverse (leakage) current that will flow at the specified voltage and temperature.
V_F	Maximum Forward Voltage: The maximum forward voltage the device will exhibit at a specified current.
V_R	Reverse Voltage: The reverse voltage dc value, no alternating component.
V_{RRM}	Repetitive Peak Reverse Voltage: The peak reverse voltage including all repetitive transient voltages but excluding all non-repetitive transient voltages.
V_{RWM}	Working Peak Reverse Voltage: The maximum peak voltage that can be applied over the operating temperature range excluding all transient voltages (ref JESD282-B). Also sometimes known as PIV.

ELECTRICAL CHARACTERISTICS @ 25 °C unless otherwise stated

PART NUMBER	Working Peak Reverse Voltage V_{RWM}	Repetitive Peak Reverse Voltage V_{RRM}	Reverse Current I_R @ V_{RWM}	Average Forward Current $I_{F(AV)}$	Maximum Surge Current I_{FSM} @ 8.3 ms	Max Peak Forward Voltage V_F @ 8A	Max Peak Forward Voltage V_F @ 8A	CAPACITANCE C_T @ 5 V
	Volts	Volts	μA	Amps	Amps	Volts	Volts	pF
	MAX	MAX	MAX	MAX	MAX	MAX	MAX	TYPICAL
HSM880	80	80	500	8	300	.61	.78	480
HSM890	90	90	500	8	300	.61	.78	480
HSM8100	100	100	500	8	300	.61	.78	480

GRAPHS

Figure 1
Typical Forward Characteristics

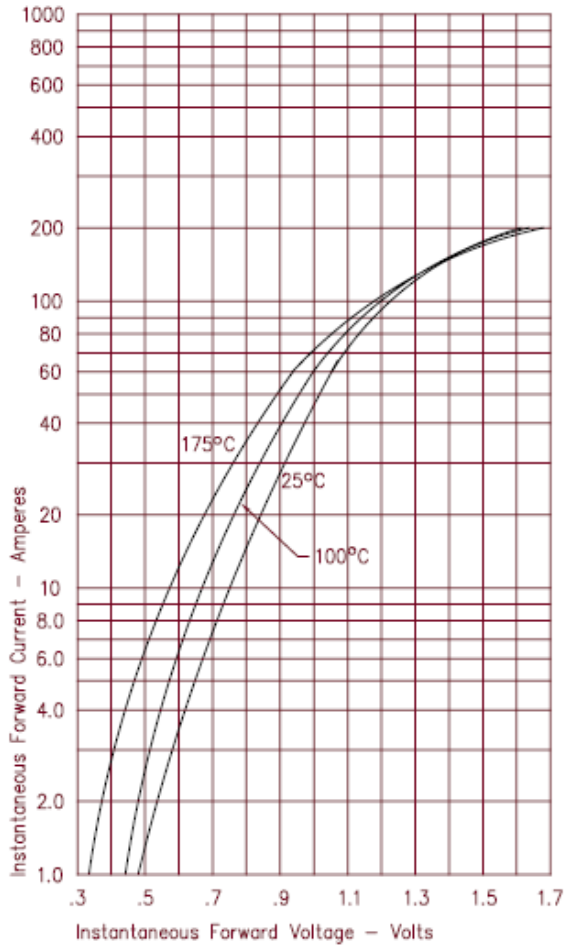

Figure 3
Typical Junction Capacitance

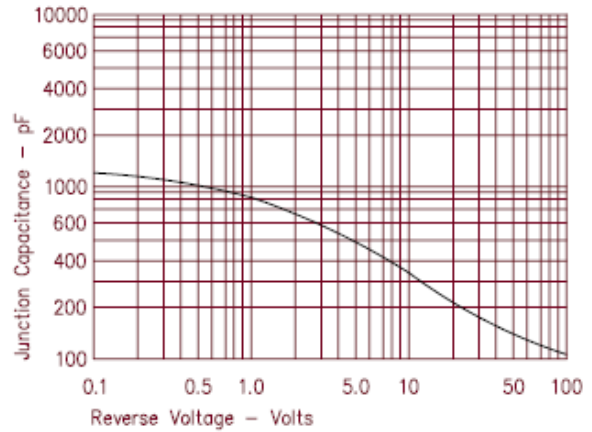
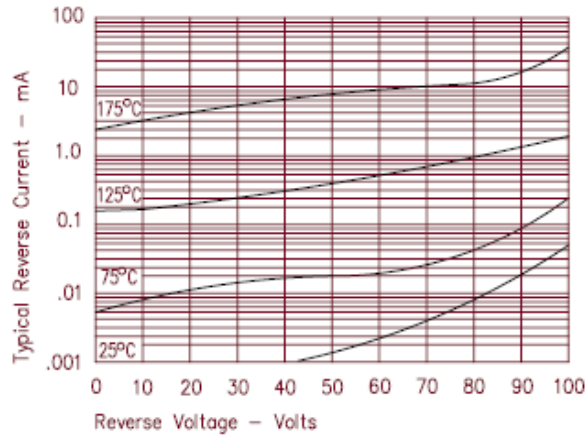
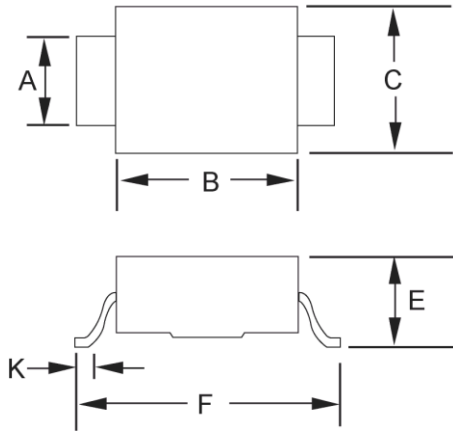
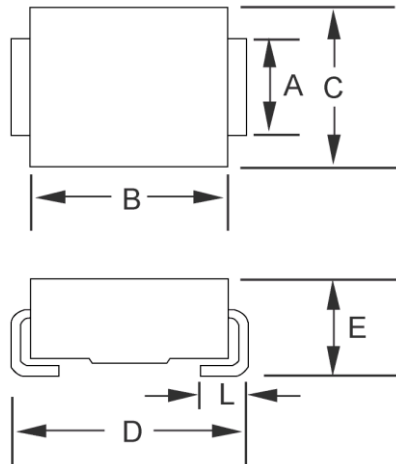

Figure 2
Typical Reverse Characteristics



PACKAGE DIMENSIONS

SMCG (DO-215AB)

Ltr	Dimensions			
	Inch		Millimeters	
	Min	Max	Min	Max
A	.117	.123	2.97	3.12
B	.260	.280	6.60	7.11
C	.220	.245	5.59	6.22
E	.075	.095	1.91	2.41
F	.380	.400	9.65	10.16
K	.025	.040	0.640	1.02

SMCJ (DO-214AB)

Ltr	Dimensions			
	Inch		Millimeters	
	Min	Max	Min	Max
A	.117	.123	2.97	3.12
B	.260	.280	6.60	7.11
C	.220	.245	5.59	6.22
D	.307	.322	7.80	8.18
E	.075	.095	1.91	2.41
L	.030	.060	.760	1.52