

## HST9-B680

### Side-View Surface-Mount Phototransistor

---

#### Description

The Broadcom<sup>®</sup> HST9-B680 is a side-view phototransistor that is available in the industry-popular 3.0 mm x 2.0 mm x 1.0 mm footprint. It is built with black epoxy that filters off visible light and this reduces unwanted noise from the visible light range. The superior package design makes this product ideal for a wide variety of applications in consumer and industrial segments.

It has a wide spectral range of sensitivity of 730 nm to 1140 nm with peak sensitivity at 970 nm. This product comes with an angle of half sensitivity of  $\pm 70$  degrees.

To facilitate easy pick-and-place assembly, the phototransistor is packed in tape and reel. It is compatible with industry-standard automatic machine placement and IR reflow soldering.

#### Features

- Silicon NPN phototransistor
- Right angle
- Black epoxy
- Wide spectral range of sensitivity of 730 nm to 1140 nm
- Peak sensitivity at 970 nm
- Angle of half sensitivity of  $\pm 70$  degrees

#### Applications

- Office automation
- Home appliances
- Light curtains

**CAUTION!** This package is ESD sensitive per ANSI/ESDA/JEDEC JS-001. Please observe appropriate precautions during handling and processing. Refer to Application Note AN-1142 for additional details.

Figure 1: Package Drawing

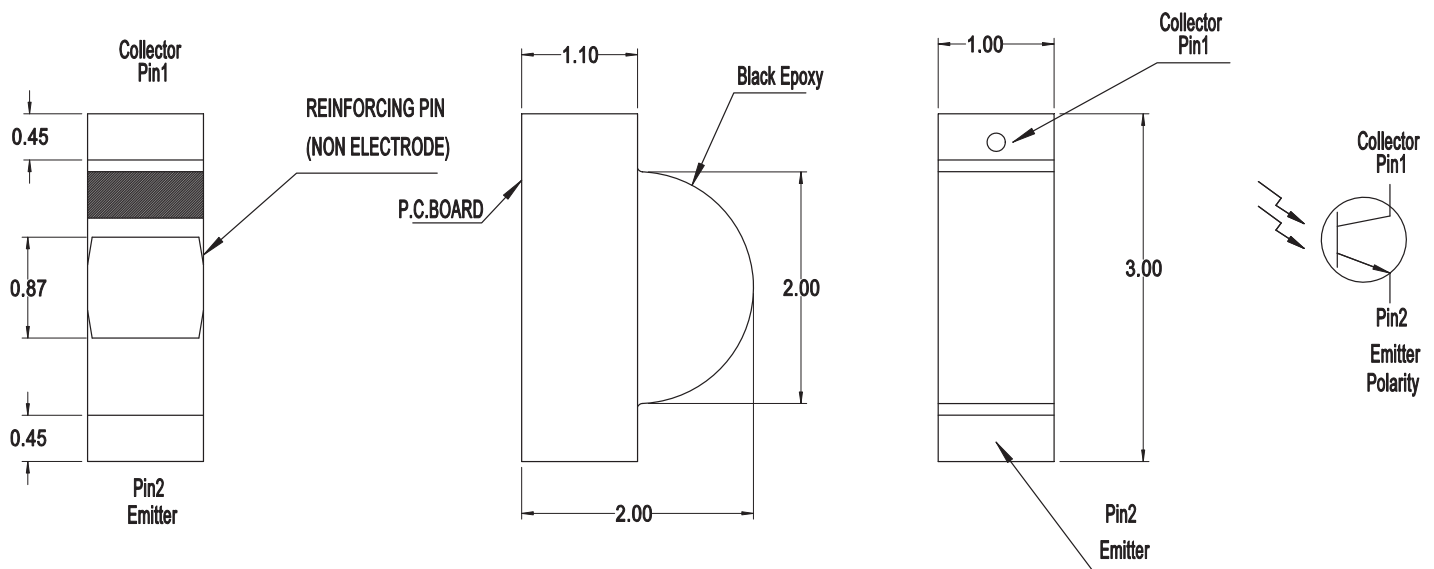
**NOTE:**

1. All dimensions are in millimeters (mm).
2. Tolerance is  $\pm 0.10$  mm unless otherwise specified.

**Absolute Maximum Ratings**

Parameter	Rating	Unit
Collector-Emitter Voltage, $V_{CE}$	30	V
Emitter-Collector Voltage, $V_{EC}$	5	V
Collector Current, $I_C$	20	mA
Power Dissipation, $P_d$	100	mW
Operating Temperature Range	-40 to +85	$^{\circ}\text{C}$
Storage Temperature Range	-40 to +100	$^{\circ}\text{C}$

**Characteristics ( $T_A = 25^{\circ}\text{C}$ )**

Parameter	Value			Unit	Test Condition
	Min.	Typ.	Max.		
Collector Light Current, $I_{ca}$	0.8	1.3	—	mA	$E_e = 1 \text{ mW/cm}^2$ , $\lambda = 940 \text{ nm}$ , $V_{CE} = 5 \text{ V}$
Wavelength of Peak Sensitivity, $\lambda_{S \text{ max}}$	—	970	—	nm	—
Spectral Range of Sensitivity, $\lambda_{0.1}$	730	—	1100	nm	—
Angle of Half Sensitivity, $\varphi$	—	$\pm 70$	—	$^{\circ}$	—
Dark Current, $I_{CEO}$	—	—	100	nA	$E_e = 0 \text{ mW/cm}^2$ , $V_{CE} = 10 \text{ V}$
Collector-Emitter Saturation Voltage, $V_{CEsat}$	—	—	0.4	V	$E_e = 1 \text{ mW/cm}^2$ , $\lambda = 940 \text{ nm}$ , $I_C = 0.05 \text{ mA}$

Figure 2: Relative Sensitivity vs. Wavelength

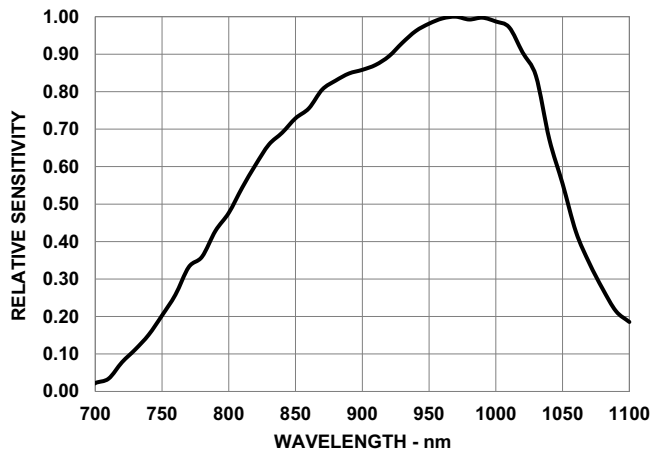

Figure 3: Relative Sensitivity vs. Angular Displacement

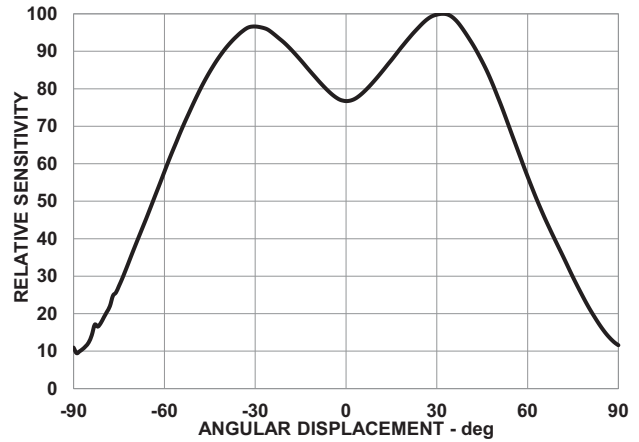

Figure 4: Collector Light Current vs. Collector-Emitter Voltage

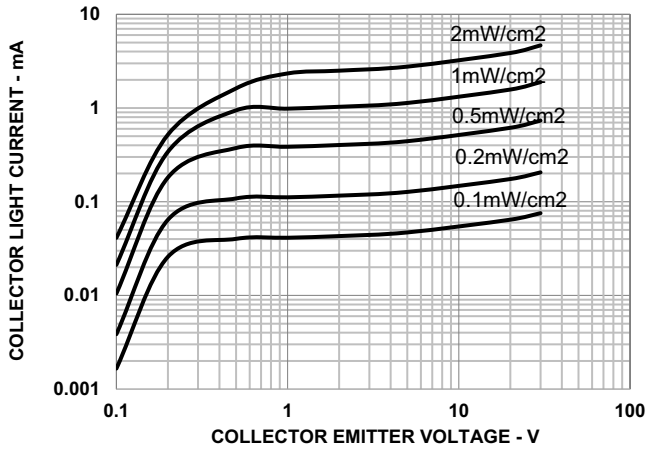

Figure 5: Collector Light Current vs. Irradiance (V<sub>CE</sub> = 5V, λ = 940 nm)

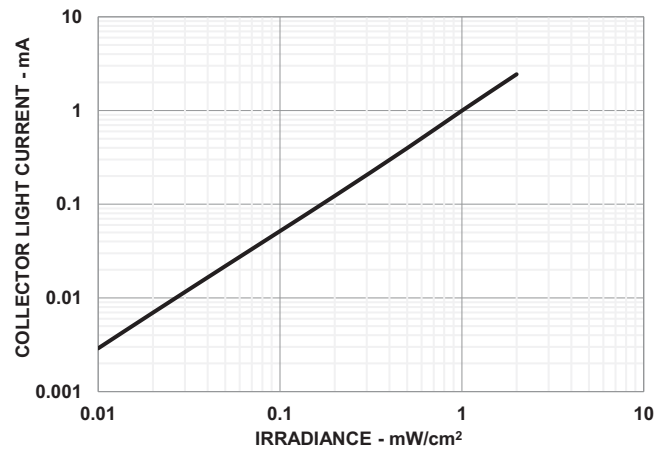

Figure 6: Dark Current vs. Ambient Temperature

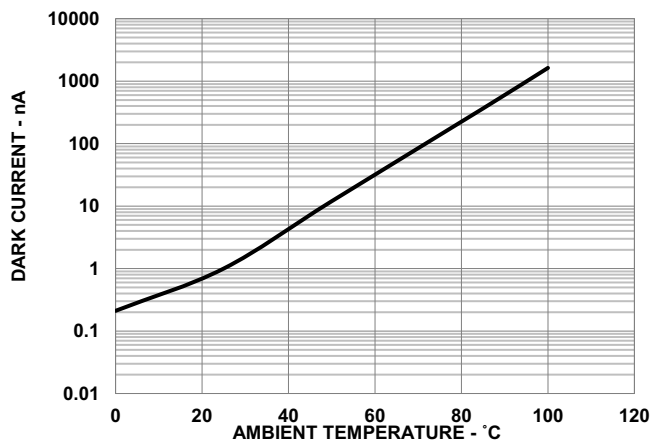

Figure 7: Relative Light Current vs. Ambient Temperature

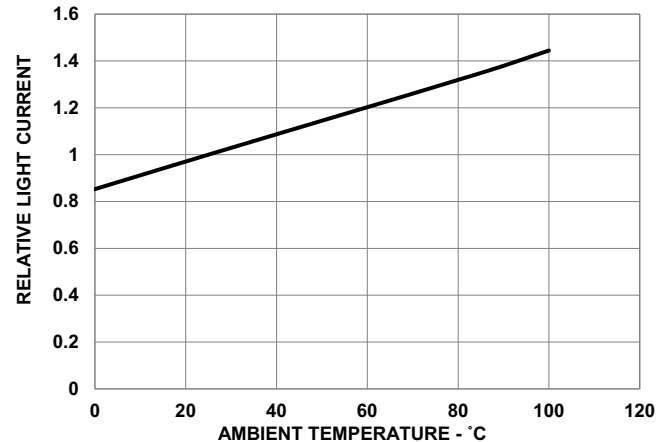

Figure 8: Recommended Soldering Land Pattern

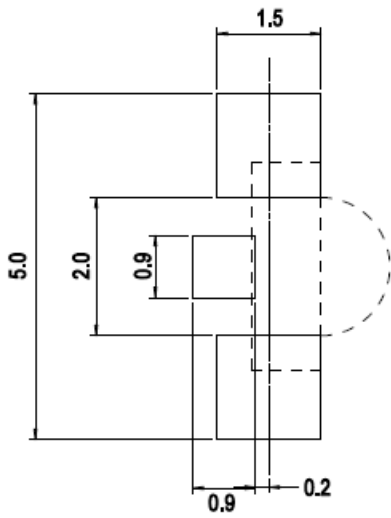
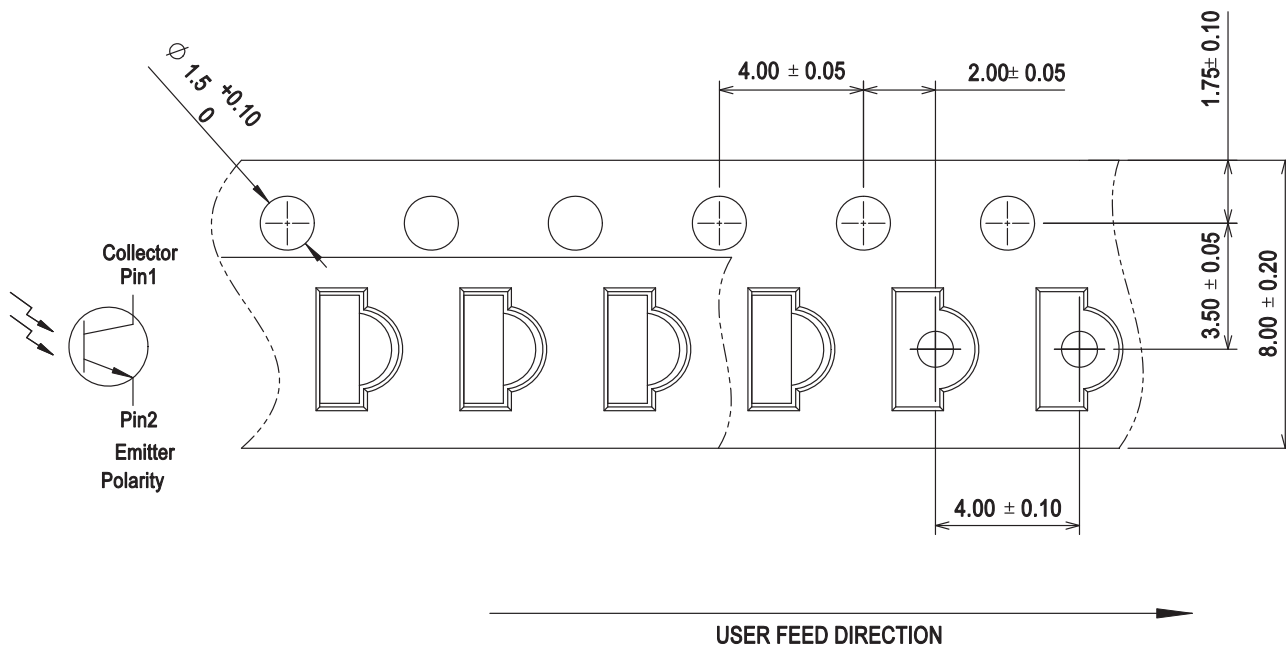
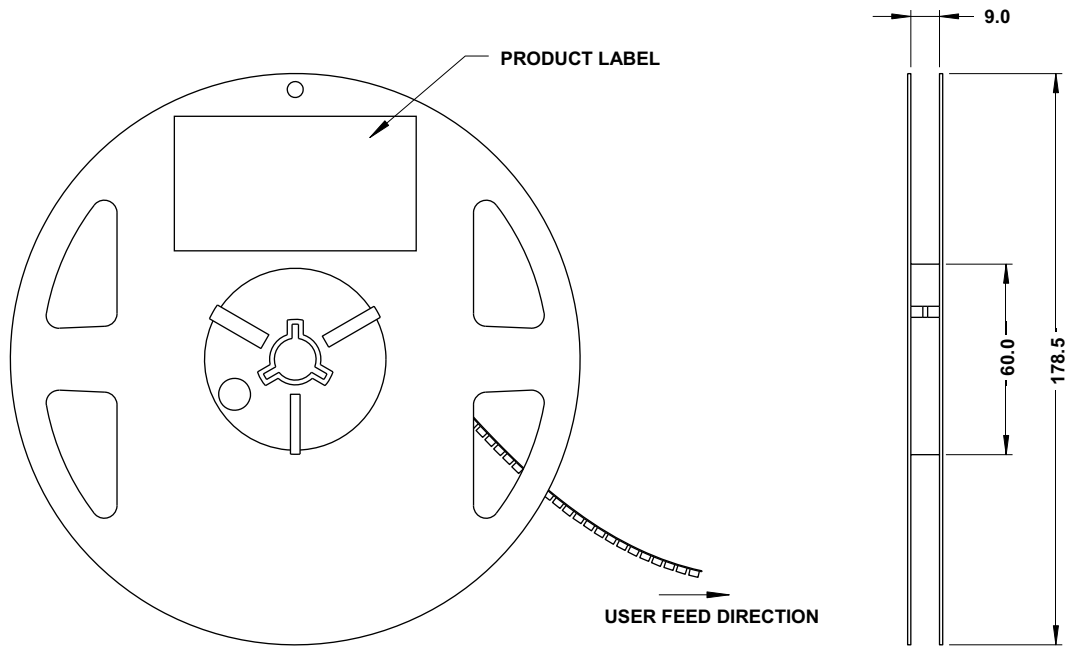

Figure 9: Carrier Tape Dimensions



**NOTE:** All dimensions in are millimeters (mm).

Figure 10: Reel Dimensions



**NOTE:** All dimensions are in millimeters (mm).

## Precautionary Notes

### Soldering

- Do not perform reflow soldering more than twice. Observe necessary precautions of handling moisture-sensitive devices as stated in the following section.
- Do not apply any pressure or force on the package during reflow and after reflow when the package is still hot.
- Use reflow soldering to solder the package. Use hand soldering only for rework if unavoidable, but it must be strictly controlled to following conditions:
  - Soldering iron tip temperature = 310°C maximum
  - Soldering duration = 2 seconds maximum
  - Number of cycles = 1 only
  - Power of soldering iron = 50W maximum
- Do not touch the package body with the soldering iron except for the soldering terminals, as it may cause damage to the package.
- Confirm beforehand whether the functionality and performance of the package is affected by soldering with hand soldering.

Figure 11: Recommended Lead-Free Reflow Soldering Profile

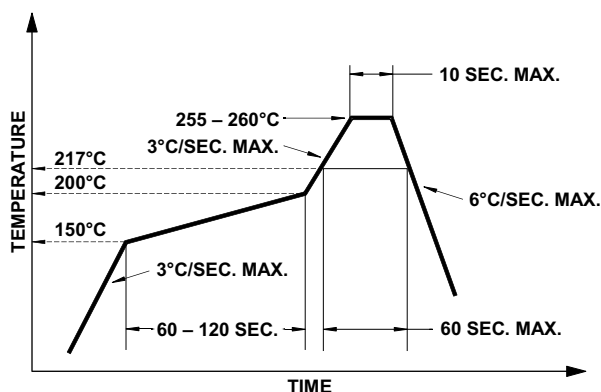

### Handling Precautions

This product has a Moisture Sensitive Level 3 rating per JEDEC J-STD-020. Refer to Broadcom Application Note AN5305, *Handling of Moisture Sensitive Surface Mount Devices*, for additional details and a review of proper handling procedures.

- Before use:
  - An unopened moisture barrier bag (MBB) can be stored at <40°C/90% RH for 12 months. If the actual shelf life has exceeded 12 months and the Humidity Indicator Card (HIC) indicates that baking is not required, then it is safe to reflow the package per the original MSL rating.
  - Do not open the MBB prior to assembly (for example, for IQC). If unavoidable, MBB must be properly resealed with fresh desiccant and HIC. The exposed duration must be taken in as floor life.
- Control after opening the MBB:
  - Read the HIC immediately upon opening of MBB.
  - Keep the LEDs at <30°/60% RH at all times, and complete all high temperature-related processes, including soldering, curing, or rework within 168 hours.
- Control for unfinished reel:
 

Store unused package in a sealed MBB with desiccant or a desiccator at <5% RH.
- Control of assembled boards:
 

If the PCB soldered with the package is to be subjected to other high-temperature processes, store the PCB in a sealed MBB with desiccant or desiccator at <5% RH to ensure that all have not exceeded their floor life of 168 hours.
- Baking is required if:
  - The HIC indicator indicates a change in color for 10% and 5%, as stated on the HIC.
  - The package is exposed to conditions of >30°C/60% RH at any time.
  - The package's floor life exceeded 168 hours.

The recommended baking condition is 60°C ± 5°C for 20 hours.

Baking can only be done once.

### Application Precautions

- If the package is intended to be used in a harsh or an outdoor environment, protect the package against damages caused by rain water, water, dust, oil, corrosive gases, external mechanical stresses, and so on.