

# Stripline Mounting Non-reflective Terminations

## HT Series

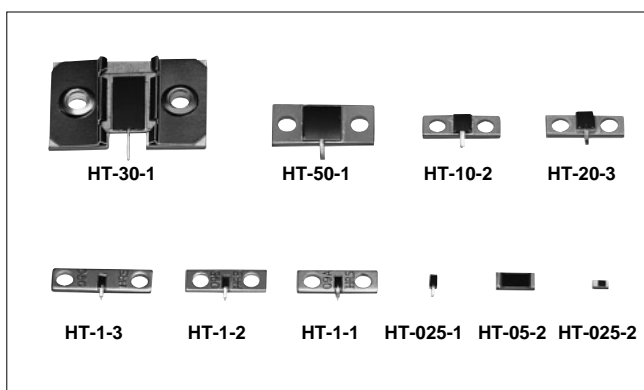

### ■Features

#### 1.High Performance

These super wide bandwidth/ultra high matching non-reflective termination use Hirose Electric original high frequency matching technology.

#### 2.Equipped with Tabs

Termination are equipped with tabs to permit direct mounting to flat circuits.

#### 3.Housing functions as a radiator to permit small size and high-density mounting.

### ■Product Specifications

Ratings	Rated frequency range (Note) Characteristic impedance Maximum Input Power (Note)	DC to 15.0 GHz 50 ohms 0.25 to 50 W	Operating temperature range Operating relative humidity	-10°C to +60°C 95% Max.
---------	----------------------------------------------------------------------------------------	-------------------------------------------	------------------------------------------------------------	----------------------------

NOTE: The frequency range and the maximum input power will differ depending on the products.

#### HT-025-1, HT-025-2, HT-05-2, HT-1-1, HT-1-2, HT-1-3, HT-10-2, HT-20-3, and HT-50-1

Item	Standard	Conditions
1.Vibration	No electrical discontinuity of 1 $\mu$ s or more No damage, cracks, or parts dislocation	Frequency of 10 to 2000 Hz, overall amplitude of 1.52 mm, acceleration of 98 m/s <sup>2</sup> for 2 hours in each of 3 directions
2.Shock		Acceleration of 490 m/s <sup>2</sup> , sine half-wave waveform, 3 cycles in each of the 3 axis
3.Temperature cycle	No damage, cracks, or parts dislocation	Temperature: -55°C → +5°C to +35°C → +85°C → +5°C to +35°C Time: 30 → 15 max. → 30 → 15 max. (Minutes) 200 cycles

●The test method conforms to MIL-STD-202.

#### HT-30-1

Item	Standard	Conditions
1.Vibration	No electrical discontinuity of 1 $\mu$ s or more No damage, cracks, or parts dislocation	Frequency of 10 to 2000 Hz, overall amplitude of 1.52 mm, acceleration of 98 m/s <sup>2</sup> for 2 hours in each of 3 directions
2.Shock		Acceleration of 294 m/s <sup>2</sup> , sine half-wave waveform, 3 cycles in each of the 3 axis
3.Temperature cycle	No damage, cracks, or parts dislocation	Temperature: -55°C → +5°C to +35°C → +120°C → +5°C to +35°C Time: 30 → 15 max. → 30 → 15 max. (Minutes) 200 cycles

●The test method conforms to MIL-STD-202.

### ■Materials

#### HT-025-1, HT-025-2, and HT-05-2

Part	Material	Finish
Tabs	Copper	Solder plating
Resistor	Metal film	———

#### HT-30-1

Part	Material	Finish
Plate	Aluminum	Conductive alumite
Retaining plate	Phosphor bronze	Nickel plating
Tabs	Copper	Tin plating
Resistor	Metal film	———

#### HT-1-1, HT-1-2, and HT-1-3

Part	Material	Finish
Plate	Aluminum	Nickel plating
Tabs	Copper	Solder plating
Resistor	Metal film	———

#### HT-10-2, HT-20-3, and HT-50-1

Part	Material	Finish
Plate	Copper	Nickel plating
Tabs	Copper	Silver plating
Resistor	Metal film	———

## Ordering Information

**HT** - **025** - **1**  
 ①            ②            ③

① Series Name: HT Series	③ Suffix
② Power (Example)0.25:0.25W 1:1W	

## Specifications

Part Number	Frequency Range (GHz)	V.S.W.R. (MAX)	Impedance (Ohms)	Power (W)	Heat Sink Temperature at Maximum Load (°C Max)	Heat Resistance (°C/W)	Weight (g)
HT-025-1	DC-8	1.30	50	1/4	+65	50	0.1
HT-025-2	DC-8	1.30	50	1/4	+65	50	0.1
HT-05-2	DC-1	1.20	50	1/2	+65	150	0.3
HT-1-1	DC-8	1.30	50	1	+65	50	0.3
HT-1-2							
HT-1-3							
HT-10-2	DC-6	1.20	50	10	+65	9	0.3
△ HT-20-3	DC-15	1.15(DC-4GHz)	50	20	+65	3.8	0.6
		1.25(4-8GHz)					
		1.45(8-12.4GHz)					
		1.55(12.4-15GHz)					
HT-30-1	DC-1	1.20	50	30	+65	3	3
△ HT-50-1	DC-5	1.25	50	50	+65	1.6	1.5

△ CAUTION: Beryllia is used in this product. Please follow associated laws when disposing.

## Typical Data

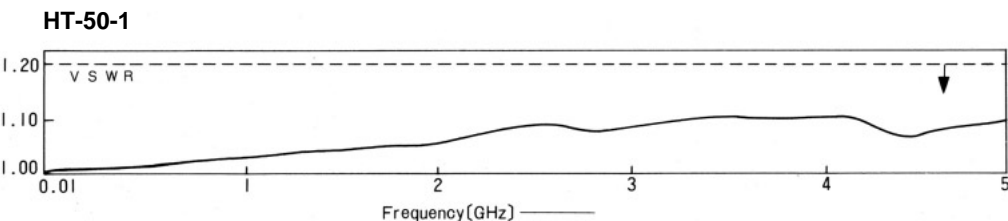
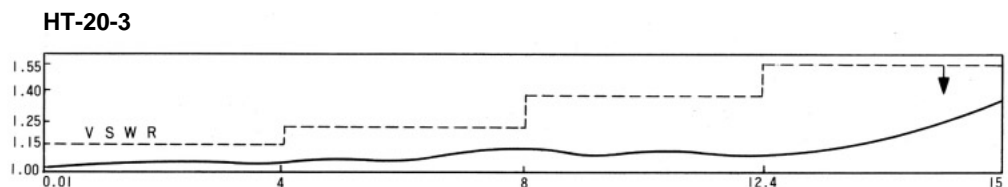
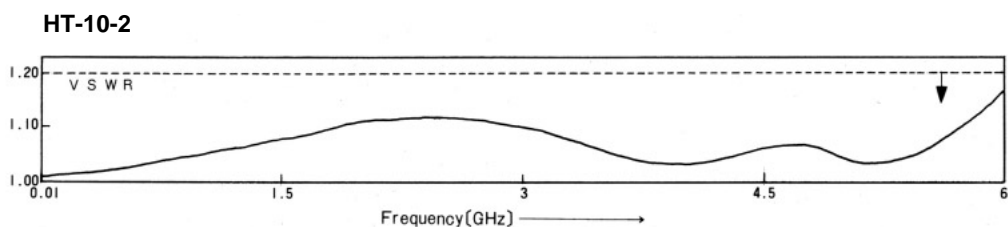
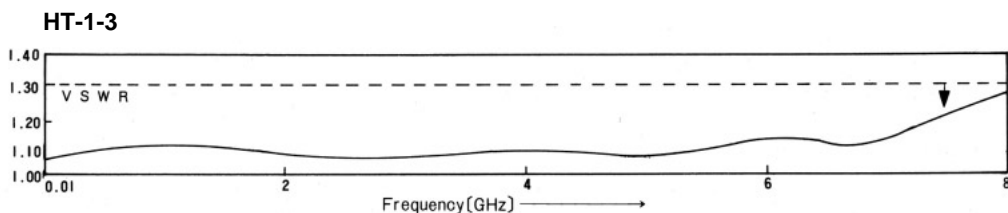

## External Dimensions

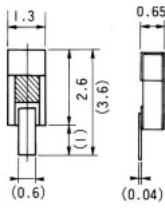

HT-025-1

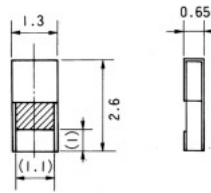

HT-025-2

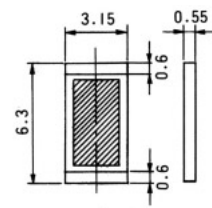

HT-05-2

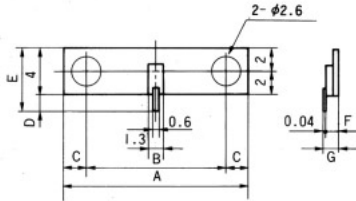

PCB Mounting Pattern

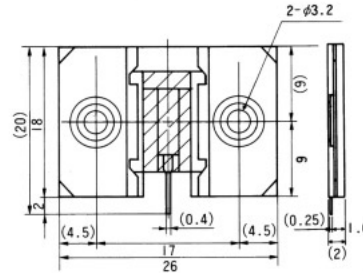

PCB Mounting Pattern

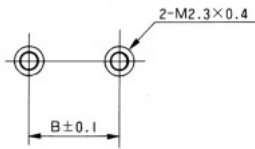

HT-1-1 · HT-1-2 · HT-1-3

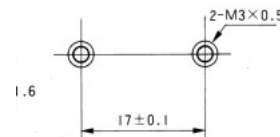

HT-30-1

Part Number	A	B	C	D	E	F	G
HT-1-1	13	8	2.5	1.4	5.4	1.45	1.49
HT-1-2	13	8	2.5	1.4	5.4	1.15	1.19
HT-1-3	16	12	2	1.4	5.4	1.45	1.49

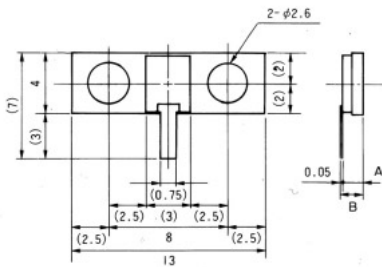

PCB Mounting Pattern

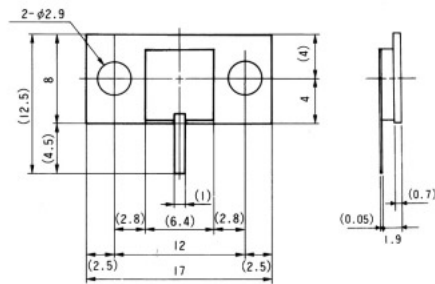

PCB Mounting Pattern

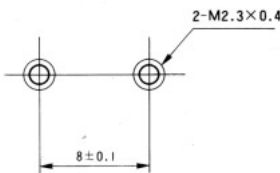

HT-10-2  
HT-20-3

Part Number	A	B
HT-10-2	1.65	1.7
HT-20-3	2	2.05

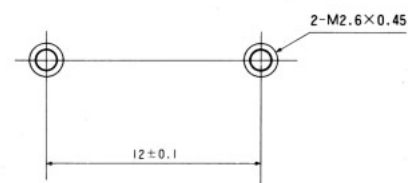

HT-50-1

## ■ Mounting Method

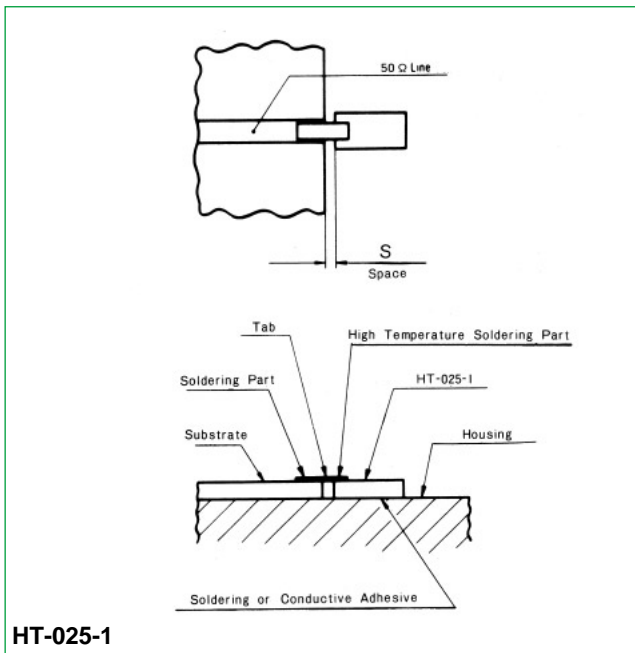

- Do not leave a space between the terminator and the microstrip board.
- Make the terminator tab height from the housing and the thickness of the microstrip board the same amount.
- Note: The HT-025-1 type is attached with high temperature solder (having a melting point of 280°C). The soldering temperature to the microstrip board must be less than this.

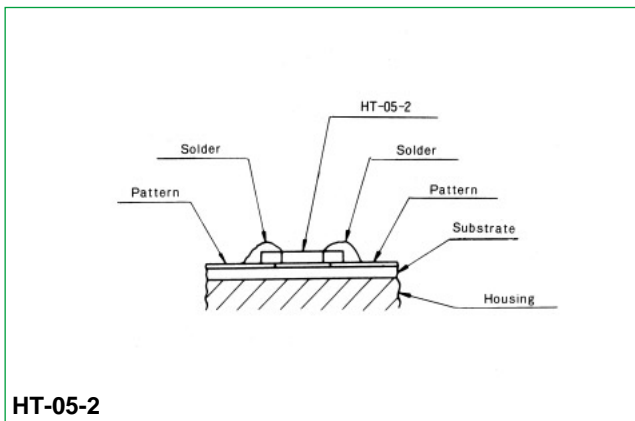

- Mounting is performed by soldering over the microstrip line pattern.
- The mounting should be completed by soldering within 5 seconds using Sn-Pb type eutectic solder containing 2 to 5% Ag with a soldering iron adjusted to about 260°C.
- The resoldering of an item that has already been soldered once and then removed is not effective since solder cracks will develop at the electrode portion.

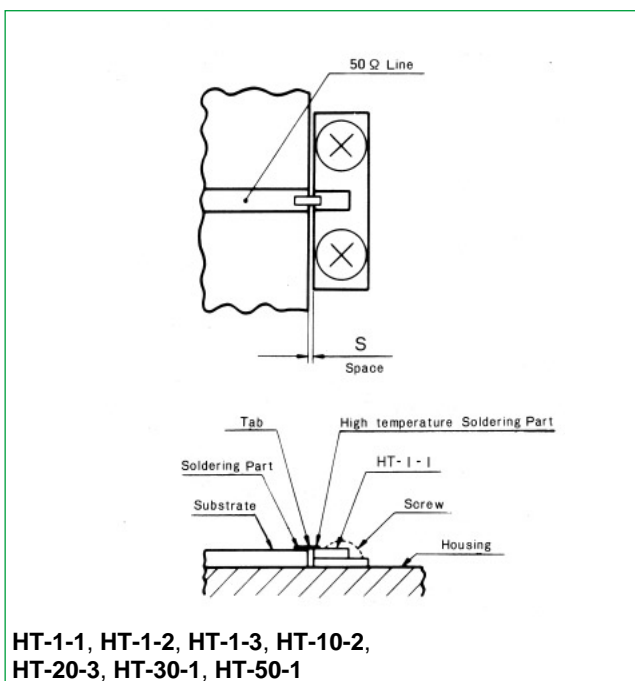

- Do not leave a space between the terminator and the microstrip board.
- Do not leave a space between the the microstrip board.
- Note: The HT-1-1, HT-1-2, HT-1-3, HT-10-2, HT-20-3, and HT-50-1 tabs are attached with high temperature solder (having a melting point of 280°C). The soldering temperature to the microstrip board must be less than this.

Note: Although the high frequency characteristics will deteriorate somewhat, please attach with some slack in the tabs in order to raise the thermal reliability.