

## HTD series – digital differential pressure sensors

---

The HTD differential pressure sensors are specially developed for pressure ranges from 1 mbar to 10 bar and demanding space constrictions. The sensors allow for flexible direct manifold assemblies and offer high performance and accuracy. A digital interface and analog voltage output provide OEMs maximum flexibility for any type of application.

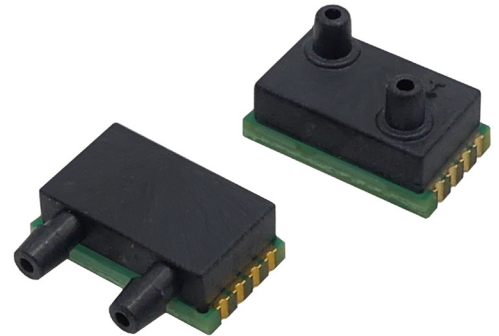

---

### Features

- Pressure ranges from 1 mbar to 10 bar
- Single 5 V or 3 V supply
- Max. output current 1 mA
- Digital SPI or I<sup>2</sup>C and analog output
- Temperature compensated range 0...70 °C
- Operating temperature range -25...+85 °C
- Total pressure accuracy down to max. 0.5 %FS
- 15 bit A/D resolution
- Outstanding offset stability
- Small footprint, low profile
- Pressure ports for direct manifold assemblies

---

### Certificates

- Quality Management System according to EN ISO 13485 and EN ISO 9001
- RoHS compliant

---

### Media compatibility

Pressure port P1 and P2:  
Non-corrosive gases compatible with silicon, RTV, ceramics Al<sub>2</sub>O<sub>3</sub>, Pyrex, epoxy, FR4, LCP plastics.

---

### Applications

#### Medical

- Ventilators
- Spirometers
- CPAP
- Sleep diagnostic equipment
- Nebulizers
- Oxygen conservers/concentrators
- Insufflators/endoscopy

#### Industrial

- HVAC
  - VAV
  - Filter monitoring
  - Burner control
- Fuel cells
- Gas leak detection
- Fume hood
- Instrumentation
- Security systems

## HTD series – digital differential pressure sensors

### Maximum ratings

Parameter		Min.	Max.	Unit
Supply voltage	HTD...P	4.75	5.25	V <sub>CC</sub>
	HTD...Q	2.70	3.3	
Output current			1	mA
Lead specifications	Average preheating temperature gradient		2.5	K/s
	Soak time		approx. 3	min.
	Time above 217 °C		50	
	Time above 230 °C		40	s
	Time above 250 °C		15	
	Peak temperature		260	°C
	Cooling temperature gradient		-3.5	K/s
Temperature ranges	Compensated	0	+70	
	Operating	-25	+85	°C
	Storage	-40	+125	

### Pressure sensor characteristics

Part no.	Operating pressure	Over pressure <sup>(1), (3)</sup>	Burst pressure <sup>(2), (3)</sup>
HTDM001...	1 mbar		
HTDM2x5...	2.5 mbar		
HTDM005...	5 mbar	100 mbar	100 mbar
HTDM010...	10 mbar		
HTDM020...	20 mbar	200 mbar	300 mbar
HTDM050...	50 mbar	500 mbar	750 mbar
HTDM100...	100 mbar	1 bar	1.5 bar
HTDM350...	350 mbar	1 bar	1.7 bar
HTDB001...	1 bar	3 bar	5 bar
HTDB002...	2 bar	6 bar	10 bar
HTDB005...	5 bar	15 bar	25 bar
HTDB007..	7 bar	21 bar	25 bar
HTDB010...	10 bar	25 bar	25 bar

#### Specification notes

(1) Over pressure is the maximum pressure which may be applied without causing damage to the sensing element.

(2) Burst pressure is the maximum pressure which may be applied without causing leakage damage to the sensing element.

(3) The max. common mode pressure is 25 bar.

## HTD series – digital differential pressure sensors

### Performance characteristics

( $T_A = 25\text{ °C}$ )

Parameter		Min.	Typ.	Max.	Unit
Accuracy (@ 25 °C) <sup>(4)</sup>	up to 5 mbar		±2	±4	
	10 to 100 mbar		±0.5	±1	
	all others		±0.1	±0.3	
Total accuracy (0...70 °C) <sup>(5)</sup>	up to 5 mbar		±2.5	±5	
	10 to 100 mbar		±0.75	±1.25	
	all others		±0.25	±0.5	
Nonlinearity (BFSL) <sup>(6)</sup>			±0.1	±0.3	
Repeatability <sup>(7)</sup>	up to 5 mbar		±0.1		%FSS
	10 to 100 mbar		±0.05		
	all others		±0.01		
Position sensitivity	up to 5 mbar		±0.6		
	10 to 100 mbar		±0.05		
	all others		±0.01		
Long term drift (one year)	up to 5 mbar		±0.5		
	10 to 100 mbar		±0.1		
	all others		±0.05		
Response time @ 15 bit			2.2		ms
A/D resolution			15		Bit
D/A resolution				11	
Load resistance		2		∞	kΩ
Current consumption			4	6.5	mA

#### Specification notes

- (4) Accuracy includes all effects (offset, span, non-linearity, pressure hysteresis and repeatability) at room temperature and represents maximum deviation of transducer signal from ideal characteristic.
- (5) Total accuracy includes all effects (offset, span, non-linearity, pressure hysteresis and repeatability) included with all temperature effects of offset and span. It describes overall error and represents maximum deviation of transducer signal from ideal characteristic in compensated temperature range from 0...70 °C.
- (6) Non-linearity is defined as the BFSL (best fit straight line) across entire pressure range.
- (7) Repeatability is defined as typical deviation of the output signal after 10 pressure cycles.

## HTD series – digital differential pressure sensors

### Performance characteristics – 5 V devices

( $V_{CC}=5\text{ V}$ ,  $T_A=25\text{ °C}$ )

#### Analog output <sup>(8)</sup>

##### Unidirectional pressure devices

Parameter	Min.	Typ.	Max.	Unit
Zero pressure offset		0.5		
Full scale span (FSS) <sup>(9)</sup>		4.0		V
Full scale output		4.5		

##### Bidirectional pressure devices

Parameter	Min.	Typ.	Max.	Unit
Zero pressure offset		2.5		
Full scale span (FSS) <sup>(9)</sup>		4.0		V
Output		4.5		
	at max. specified pressure			
	at min. specified pressure	0.5		

#### Digital output (15 bit)

##### Unidirectional pressure devices

Parameter	Min.	Typ.	Max.	Unit
Zero pressure offset		3277		
Full scale span (FSS) <sup>(9)</sup>		26214		Counts
Full scale output		29491		

##### Bidirectional pressure devices

Parameter	Min.	Typ.	Max.	Unit
Zero pressure offset		16384		
Full scale span (FSS) <sup>(9)</sup>		26214		Counts
Output		29491		
	at max. specified pressure			
	at min. specified pressure	3277		

#### Specification notes

- (8) Analog output signal is ratiometric to power supply  $V_{CC}$ , digital signal is not ratiometric to the power supply.
- (9) Full Scale Span (FSS) is the algebraic difference between the output signal for the highest and lowest specified pressure.

## HTD series – digital differential pressure sensors

### Performance characteristics – 3 V devices

( $V_{CC}=3\text{ V}$ ,  $T_A=25\text{ °C}$ )

#### Analog output <sup>(8)</sup>

##### Unidirectional pressure devices

Parameter	Min.	Typ.	Max.	Unit
Zero pressure offset		0.3		
Full scale span (FSS) <sup>(9)</sup>		2.4		V
Full scale output		2.7		

##### Bidirectional pressure devices

Parameter	Min.	Typ.	Max.	Unit
Zero pressure offset		1.5		
Full scale span (FSS) <sup>(9)</sup>		2.4		V
Output		2.7		
	at max. specified pressure			
	at min. specified pressure	0.3		

#### Digital output (15 bit)

##### Unidirectional pressure devices

Parameter	Min.	Typ.	Max.	Unit
Zero pressure offset		3277		
Full scale span (FSS) <sup>(9)</sup>		26214		Counts
Full scale output		29491		

##### Bidirectional pressure devices

Parameter	Min.	Typ.	Max.	Unit
Zero pressure offset		16384		
Full scale span (FSS) <sup>(9)</sup>		26214		Counts
Output		29491		
	at max. specified pressure			
	at min. specified pressure	3277		

#### Specification notes

- (8) Analog output signal is ratiometric to power supply  $V_{CC}$ , digital signal is not ratiometric to the power supply.
- (9) Full Scale Span (FSS) is the algebraic difference between the output signal for the highest and lowest specified pressure.

## HTD series – digital differential pressure sensors

### SPI - Serial Peripheral Interface

#### Introduction

The sensor is capable to generate a digital output signal. The device runs a cyclic program, which will store a corrected sensor value with 12 bit resolution about every 500  $\mu$ s within the output registers of the internal ASIC. This cyclic program runs independent from the bus communication. In order to use the pressure sensor for digital signal readout, it should be connected to a SPI Master device.

SPI specifies four signals: The clock (CLK) is generated by the master and input to all slaves. MOSI carries data from master to slave. MISO carries data from slave back to master. A slave select line (SS) allows individual selection of a slave device.

#### SPI Modes

A pair of parameters called clock polarity (CPOL) and clock phase (CPHA) determine the edges of the clock signal on which the data are driven and sampled. Each of the two parameters has two possible states, which allows for four possible combinations, all of which are incompatible with one another.

In general the sensor supports all combinations of clock phase (CPHA) and polarity (CPOL). By default it is programmed to CPHA = 0 and CPOL = 0, which means that data transmission starts with the rising first clock edge (see Fig 1).

#### Slave select

The falling edge of the SS line indicates the beginning of the transfer. Additionally the SS line must not be negated and reasserted between the three bytes to be transmitted.

#### Data operation

The MOSI line should always be set to high level. So there is no data transmission from master to slave. Because of internal configuration the slave will answer the first byte with a FFh. The second and third byte contain the 15 bit pressure information (see Fig. 2).

For further information please refer to First Sensor's SPI application note.

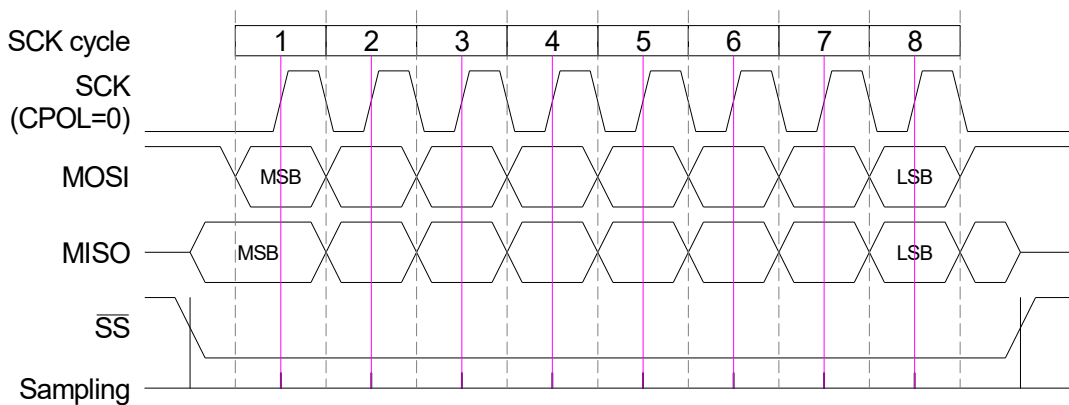

Fig. 1: Example of a standard 1 byte SPI data transfer for CPHA=0 and CPOL=0

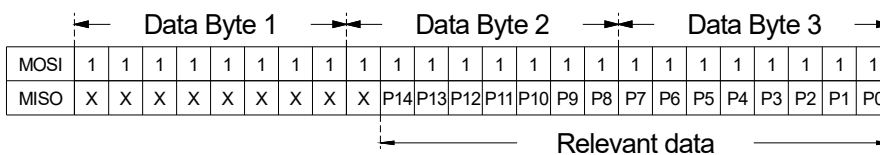

Fig. 2: 3 byte data stream between sensor and master containing the pressure value as a 15 bit information

## HTD series – digital differential pressure sensors

### SPI parameters

Parameter	Symbol	Min.	Typ.	Max.	Unit
Input high level		90		100	
Input low level		0		10	% of $V_s$
Output low level				10	
Load capacitance @ MISO	$C_{MISO}$			400	pF
Input capacitance @ ach pin	$C_{SPI\_IN}$			10	
Signal clock frequency	$F_{SCK}$	100*		640	kHz
MISO hold time after SCK sample slope	$t_{SPI\_HD\_MISO}$	200			ns
MOSI setup time before SCK sample slope	$t_{SPI\_SU\_MOSI}$	$2/f_{CLK}$			
/SS setup time before SCK sample slope	$t_{SPI\_SU\_SS}$	10			ns
/SS hold time after SCK sample slope	$t_{SPI\_HD\_SS}$	$1/f_{CLK}$			

\* recommended

**Note:** First Sensor recommends communication speeds of at least 100 kHz (max. 640 kHz).  
Please contact your nearest First Sensor sales office for further information.

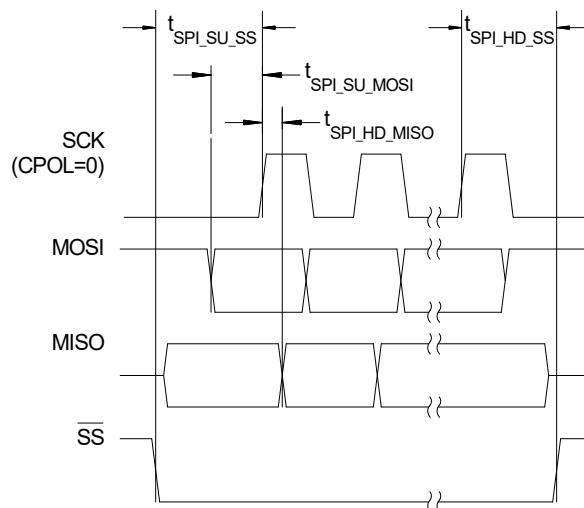

Fig. 2: Timing characteristics

## HTD series – digital differential pressure sensors

### I<sup>2</sup>C bus

#### Introduction

The sensor is capable to generate a digital output signal. The device runs a cyclic program, which will store a corrected pressure value with 12 bit resolution about every 250  $\mu$ s within the output registers of the internal ASIC. In order to use the sensor for digital signal readout, it should be connected to a bidirectional I<sup>2</sup>C-bus.

According to the I<sup>2</sup>C-bus specification, the bus is controlled by a master device, which generates the clock signal, controls the bus access and generates START and STOP conditions. The sensor is designed to work as a slave, hence it will only respond to requests from a master device.

#### Digital I<sup>2</sup>C interface

The sensor complies with the following protocol (Fig. 3):

**Bus not busy:** During idle periods both data line (SDA) and clock line (SCL) remain HIGH.

**START condition (S):** HIGH to LOW transition of SDA line while clock (SCL) is HIGH is interpreted as START condition. START conditions are always generated by the master. Each initial request for a pressure value has to begin with a START condition.

**STOP condition (P):** LOW to HIGH transition of SDA line while clock (SCL) is HIGH determines STOP condition. STOP conditions are always generated by the master. More than one request for the current pressure value can be transmitted without generation of intermediate STOP condition.

**DATA valid (D):** State of data line represents valid data when, after START condition, data line is stable for duration of HIGH period of clock signal. Data on line must be changed during LOW period of clock signal. There is one clock pulse per bit of data.

**Acknowledge (A):** Data is transferred in pieces of 8 bits (1 byte) on serial bus, MSB first. After each byte receiving device – whether master or slave – is obliged to pull data line LOW as acknowledge for reception of data. Master must generate an extra clock pulse for this purpose. When acknowledge is missed, slave transmitter becomes inactive. It is on master either to send last com-mand again or to generate STOP condition in that case.

**Slave address:** The I<sup>2</sup>C-bus master-slave concept requires a unique address for each device. The sensor has a preconfigured slave address (111100xb). By factory programming it is possible to define a secondary slave address additional to the general one. According to I<sup>2</sup>C specification 127 different addresses are available. The sensor will then listen to both slave addresses. After generating a START condition the master sends the address byte containing a 7 bit address followed by a data direction bit (R/W). A "0" indicates a transmission from master to slave (WRITE), a "1" indicates a data request (READ).

**DATA operation:** The sensor starts to send 2 data bytes containing the current pressure value as a 15 bit information placed in the output registers.

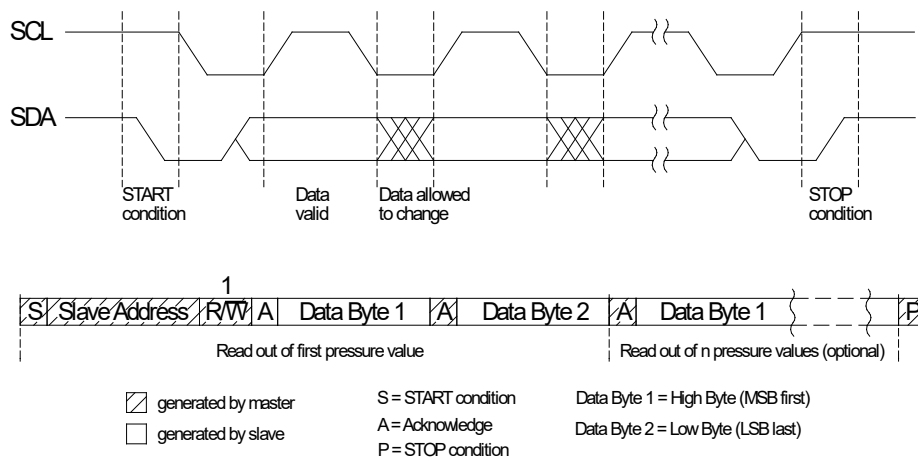

Fig. 3: I<sup>2</sup>C bus protocol



## HTD series – digital differential pressure sensors

### I<sup>2</sup>C interface parameters

Parameter	Symbol	Min.	Typ.	Max.	Unit
Input high level		90		100	
Input low level		0		10	% of V <sub>s</sub>
Output low level				10	
Pull-up resistor		500			Ω
Load capacitance @ SDA	C <sub>SDA</sub>			400	pF
Input capacitance @ SDA/SCL	C <sub>I2C_IN</sub>			10	pF
SCL clock frequency	F <sub>SCL</sub>	100*		400	kHz
Bus free time between STOP and START condition	t <sub>BUF</sub>	1.3			
Hold time (repeated) START condition, to first clock pulse	t <sub>HD,STA</sub>	0.8			
LOW period of SCL	t <sub>LOW</sub>	1.3			
HIGH period of SCL	t <sub>HIGH</sub>	0.6			
Setup time repeated START condition	t <sub>SU,STA</sub>	1			μs
Data hold time	t <sub>HD,DAT</sub>	0			
Data setup time	t <sub>SU,DAT</sub>	0.2			
Rise time of both SDA and SCL	t <sub>R</sub>			0.3	
Fall time of both SDA and SCL	t <sub>F</sub>			0.3	
Setup time for STOP condition	t <sub>SU,STO</sub>	0.6			

\* recommended

**Note:** First Sensor recommends communication speeds of at least 100 kHz (max. 400 kHz).  
Please contact your nearest First Sensor sales office for further information.

\* recommended

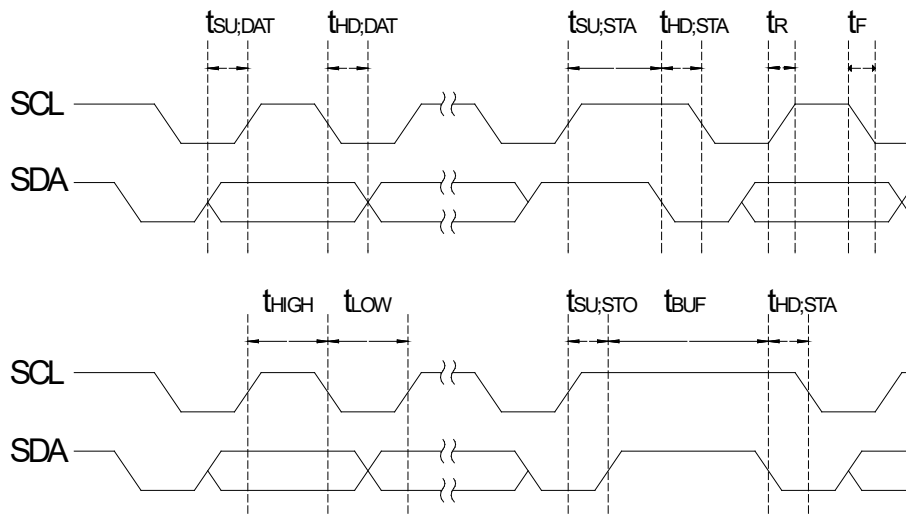
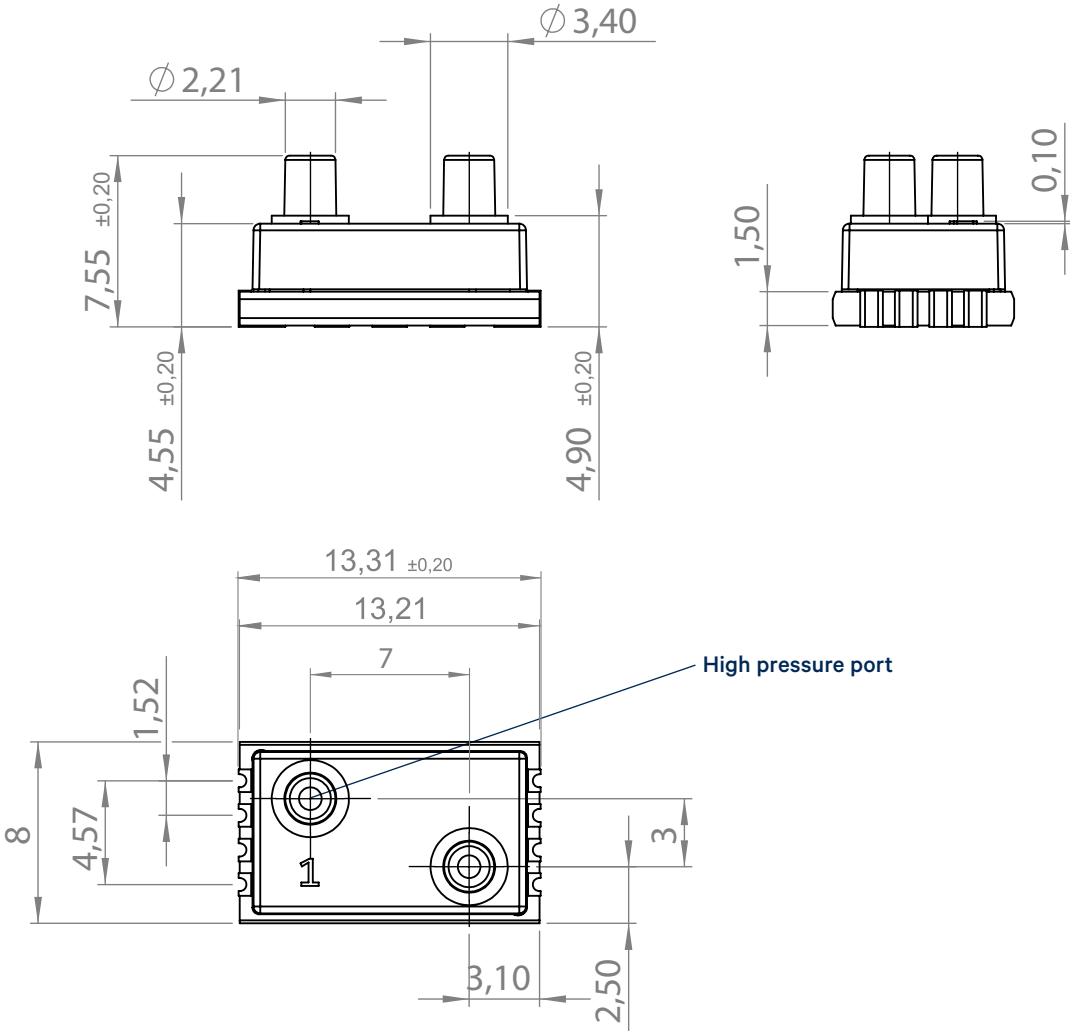

Fig. 4: Timing characteristics

## HTD series – digital differential pressure sensors

### Dimensional drawing <sup>(10)</sup>

HTD...S... (SMD, 2 ports, axial, straight port)



dimensions in mm

**Specification notes**

(10) General tolerances for mechanical parts: DIN ISO 2768  
 Tolerances and acceptance conditions for plastic molded parts: DIN 16742

## HTD series – digital differential pressure sensors

### Dimensional drawing <sup>(10)</sup>

HTD...E... (SMD, 2 ports, horizontal, barbed port)

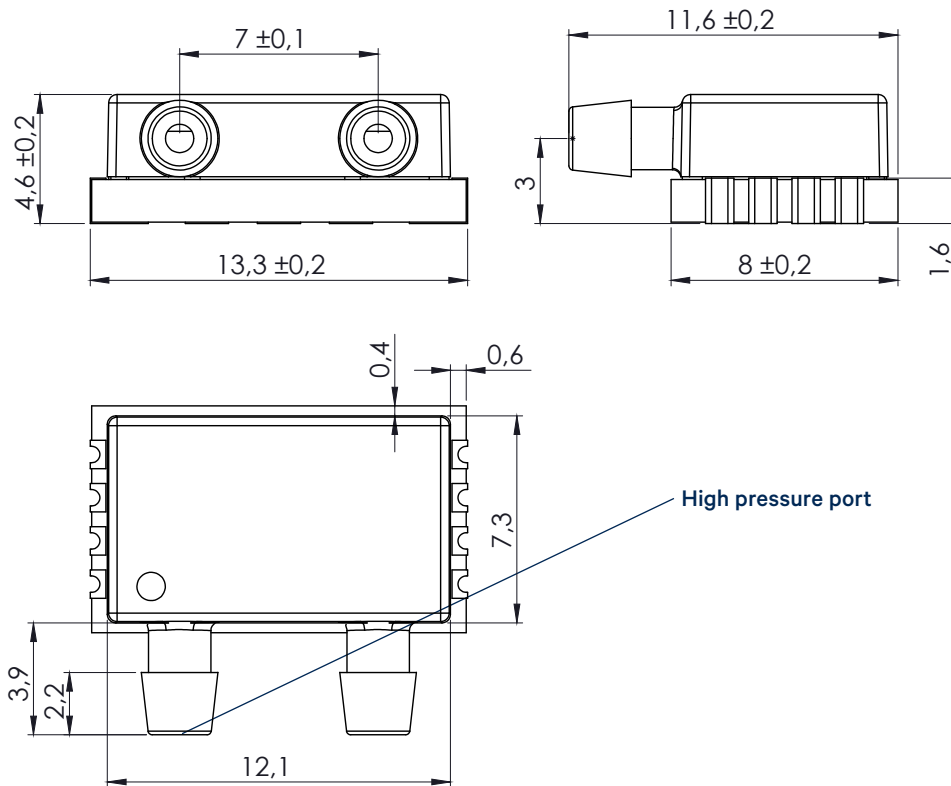

dimensions in mm

### Soldering footprints

#### Edge pins

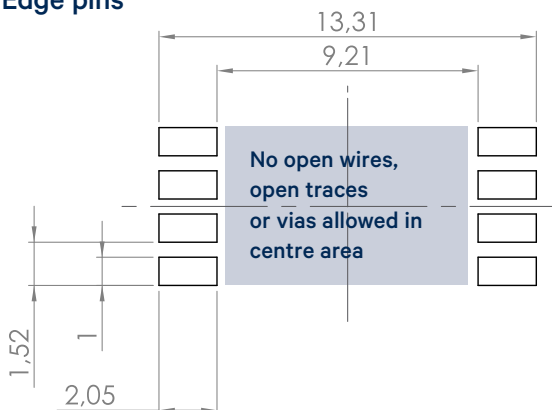

dimensions in mm

#### Specification notes

(10) General tolerances for mechanical parts: DIN ISO 2768

Tolerances and acceptance conditions for plastic molded parts: DIN 16742

## HTD series – digital differential pressure sensors

### Manifold diagram

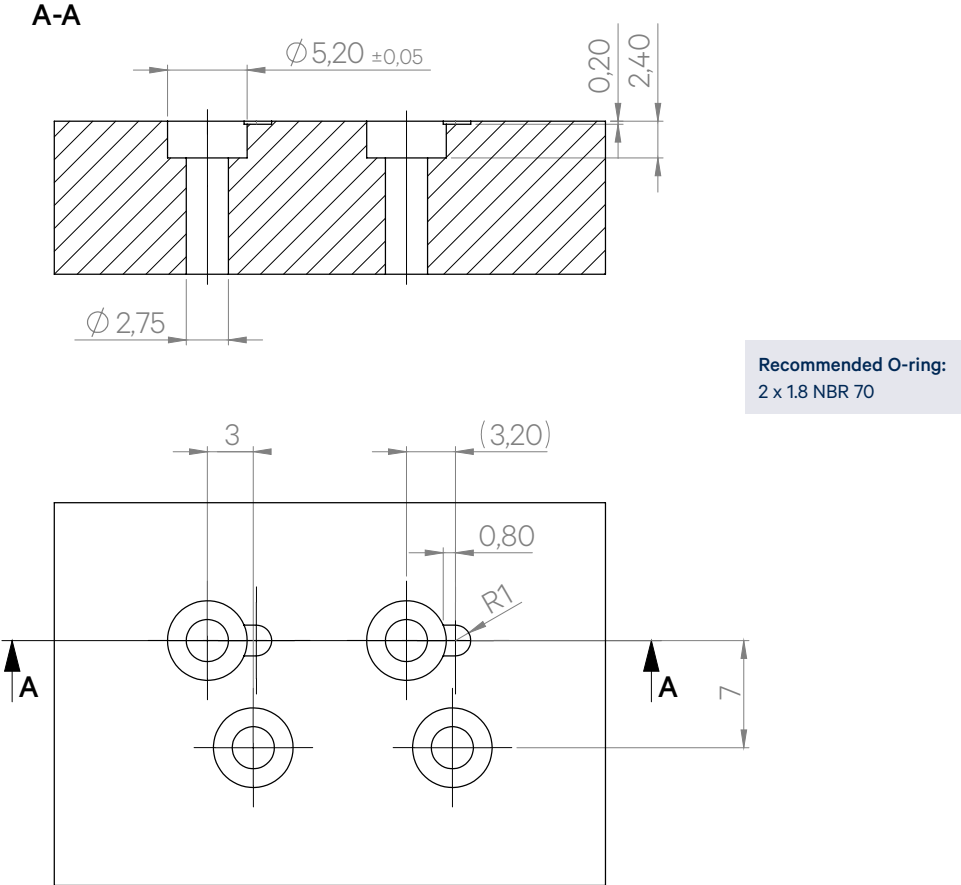

## HTD series – digital differential pressure sensors

### Custom adaptor

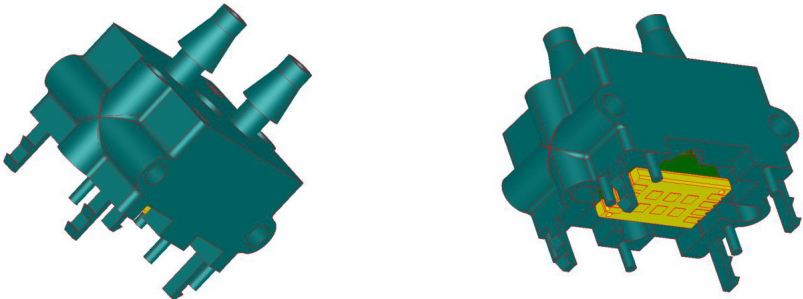

### Tape and reel packaging

13 inch reel, 500 pcs/reel

Measure	Axial port	Horizontal port
P	16	20
T	8.35	5.35

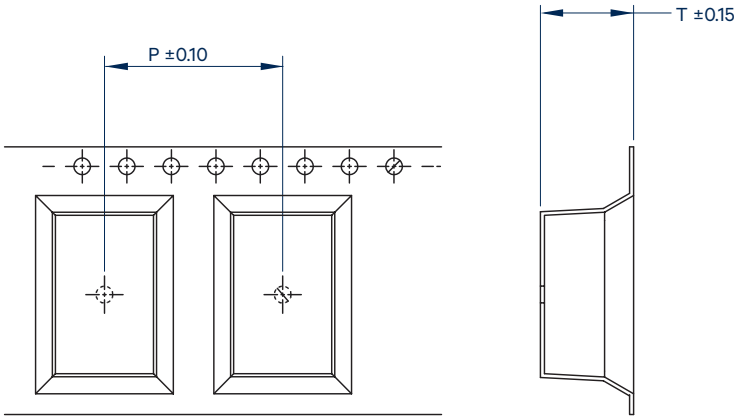
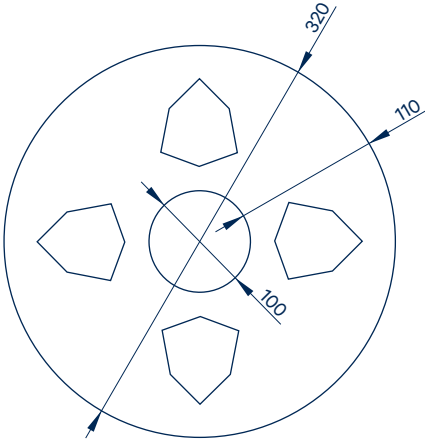

 Feed direction

dimensions in mm