

Low Noise, High Voltage EL Lamp Driver IC

Features

- ▶ Patented audible noise reduction
- ▶ Patented lamp aging compensation
- ▶ 190 V_{pp} output voltage for higher brightness
- ▶ Patented output timing for high efficiency
- ▶ Single cell lithium ion compatible
- ▶ 150nA shutdown current
- ▶ Wide input voltage range 1.8 to 5.0V
- ▶ Separately adjustable lamp and converter frequencies
- ▶ Output voltage regulation
- ▶ Split supply capability
- ▶ Available in 8-Lead MSOP and DFN packages

Applications

- ▶ LCD backlighting
- ▶ Mobile Cellular Phone
- ▶ PDAs
- ▶ Handheld wireless communication products
- ▶ Global Positioning Systems (GPS)

General Description

The Supertex HV857 is a high voltage driver designed for driving Electroluminescent (EL) lamps of up to 5.0 square inches. The input supply voltage range is from 1.8 to 5.0V. The device uses a single inductor and a minimum number of passive components. The nominal regulated output voltage that is applied to the EL lamp is $\pm 95V$. The chip can be enabled/disabled by connecting the resistor on RSW-Osc to VDD/GND.

The HV857 has two internal oscillators, a switching MOSFET, and a high voltage EL lamp driver. The frequency for the switching MOSFET is set by an external resistor connected between the RSW-Osc pin and the supply pin VDD. The EL lamp driver frequency is set by an external resistor connected between the REL-Osc pin and VDD pin. An external inductor is connected between the LX and VDD pins or V_{IN} for split supply applications. A 0.003-0.1 μF capacitor is connected between CS and ground. The EL lamp is connected between VA and VB.

The switching MOSFET charges the external inductor and discharges it into the capacitor at CS. The voltage at CS will start to increase. Once the voltage at CS reaches a nominal value of 95V, the switching MOSFET is turned OFF to conserve power. The outputs VA and VB are configured as an H bridge and are switching in opposite states to achieve $\pm 95V$ across the EL lamp.

Typical Application Circuit

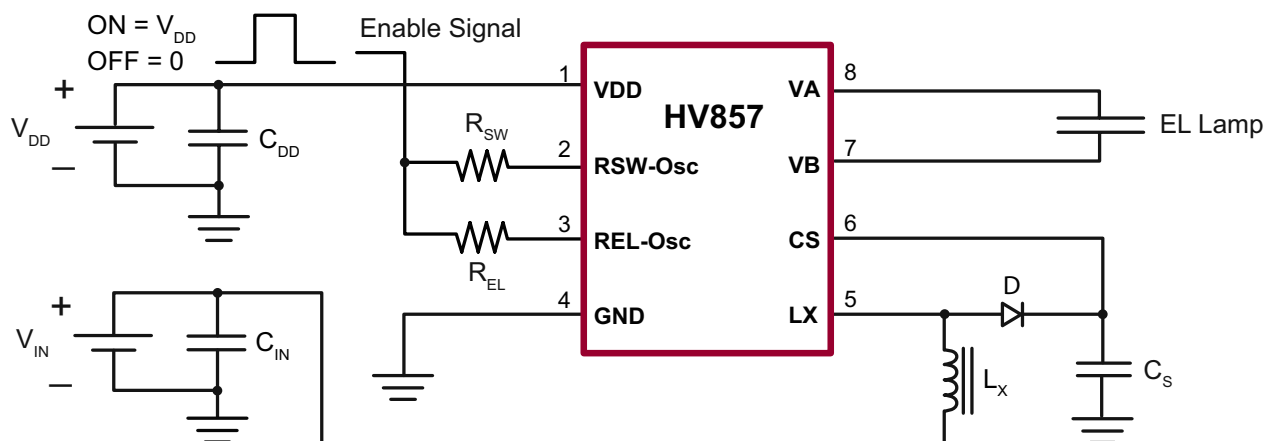

Ordering Information

Part Number	Package	Packing
HV857K7-G	8-Lead DFN	3000/Reel
HV857MG-G	8-Lead MSOP	2500/Reel

-G denotes a lead (Pb)-free / RoHS compliant package

Absolute Maximum Ratings

Parameter	Value
Supply voltage, V_{DD}	-0.5V to 6.5V
Operating temperature	-40°C to +85°C
Storage temperature	-65°C to +150°C
DFN-8 power dissipation	1.6W
MSOP-8 power dissipation	300mW
Output voltage, V_{CS}	-0.5 to +120V

Absolute Maximum Ratings are those values beyond which damage to the device may occur. Functional operation under these conditions is not implied. Continuous operation of the device at the absolute rating level may affect device reliability. All voltages are referenced to device ground.

Typical Thermal Resistance

Package	θ_{ja}
8-Lead DFN	37°C/W
8-Lead MSOP	171°C/W

Mounted on FR4 board, 25mm x 25mm x 1.57mm

Recommended Operating Conditions

Sym	Parameter	Min	Typ	Max	Units	Conditions
V_{DD}	Supply voltage	1.8	-	5.0	V	---
f_{EL}	Operating drive frequency	-	-	1.0	kHz	---
T_A	Operating temperature	-40	-	+85	°C	---

Enable/Disable Function Table

Sym	Parameter	Min	Typ	Max	Units	Conditions
EN-L	Logic input low voltage	0	-	0.2	V	$V_{DD} = 1.8$ to 5.0V
EN-H	Logic input high voltage	$V_{DD} - 0.2$	-	V_{DD}	V	$V_{DD} = 1.8$ to 5.0V

DC Electrical Characteristics (Over recommended operating conditions unless otherwise specified, $T_A = 25^\circ\text{C}$)

Sym	Parameter	Min	Typ	Max	Units	Conditions
$R_{DS(ON)}$	On-resistance of switching transistor	-	-	6.0	Ω	$I = 100\text{mA}$
V_{CS}	Max. output regulation voltage	85	95	105	V	$V_{DD} = 1.8$ to 5.0V

Pin Configuration

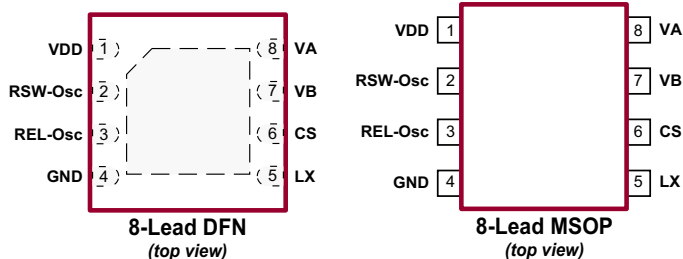

Pads are at the bottom of the package.
Exposed center pad is at ground potential.

Product Marking



Y = Last Digit of Year Sealed
W = Code for Week Sealed
L = Lot Number
— = "Green" Packaging

Package may or may not include the following marks: Si or

8-Lead DFN

Top Marking

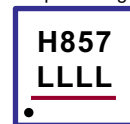

L = Lot Number
YY = Year Sealed
WW = Week Sealed
— = "Green" Packaging

Bottom Marking



Package may or may not include the following marks: Si or

8-Lead MSOP

DC Electrical Characteristics (cont.)

Sym	Parameter	Min	Typ	Max	Units	Conditions
$V_A - V_B$	Peak to Peak output voltage	170	190	210	V	$V_{DD} = 1.8$ to $5.0V$
I_{DDQ}	Quiescent V_{DD} supply current	-	-	150	nA	$R_{SW-Osc} = \text{Low}$
I_{DD}	Input current going into the VDD pin	-	-	150	μA	$V_{DD} = 1.8$ to $5.0V$. See Figure 1
I_{IN}	Input current including inductor current	-	20	25	mA	See Figure 1*
V_{CS}	Output voltage on VCS	-	84	-	V	See Figure 1
f_{EL}	EL lamp frequency	205	240	275	Hz	See Figure 1
f_{SW}	Switching transistor frequency	-	80	-	kHz	See Figure 1
D	Switching transistor duty cycle	-	88	-	%	See Figure 1

* The inductor used is a $220\mu H$ Murata inductor, max DC resistance of 8.4Ω , part # LQH32CN221K21.

Block Diagram

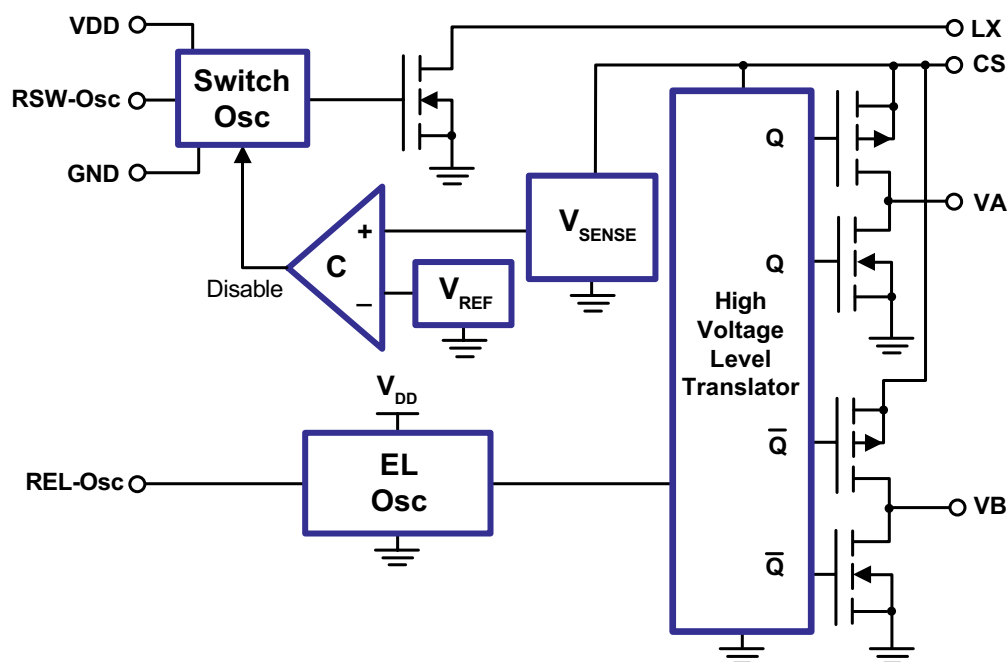
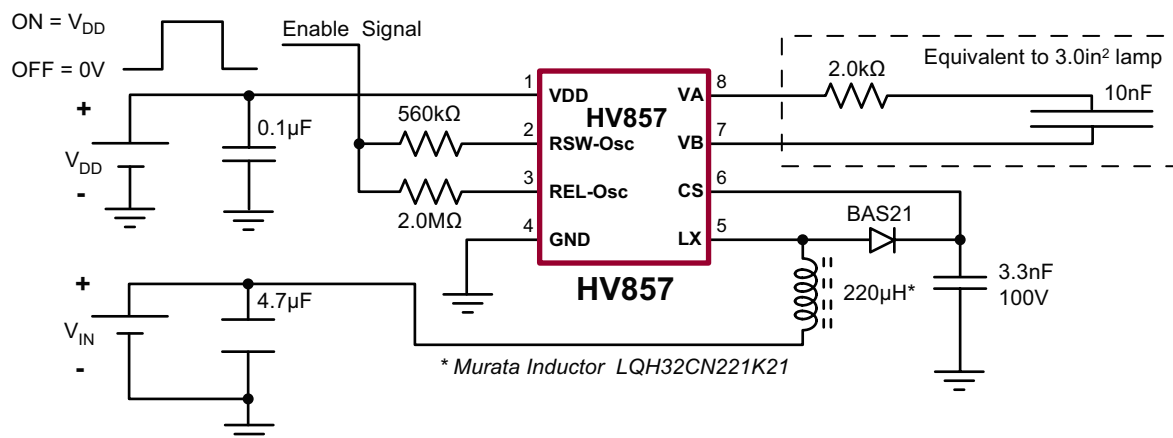

Figure 1: Typical Application/ Test Circuit



Typical Performance

Device	Lamp Size	$V_{DD} = V_{IN}$	I_{IN}	V_{CS}	f_{EL}	Brightness
HV857MG-G	3.0in ²	3.3V	20.0mA	84V	240Hz	6.0ft-Im

Typical Performance Curves for Figure 1 (*EL Lamp = 3.0in², $V_{DD} = 3.0V$*)

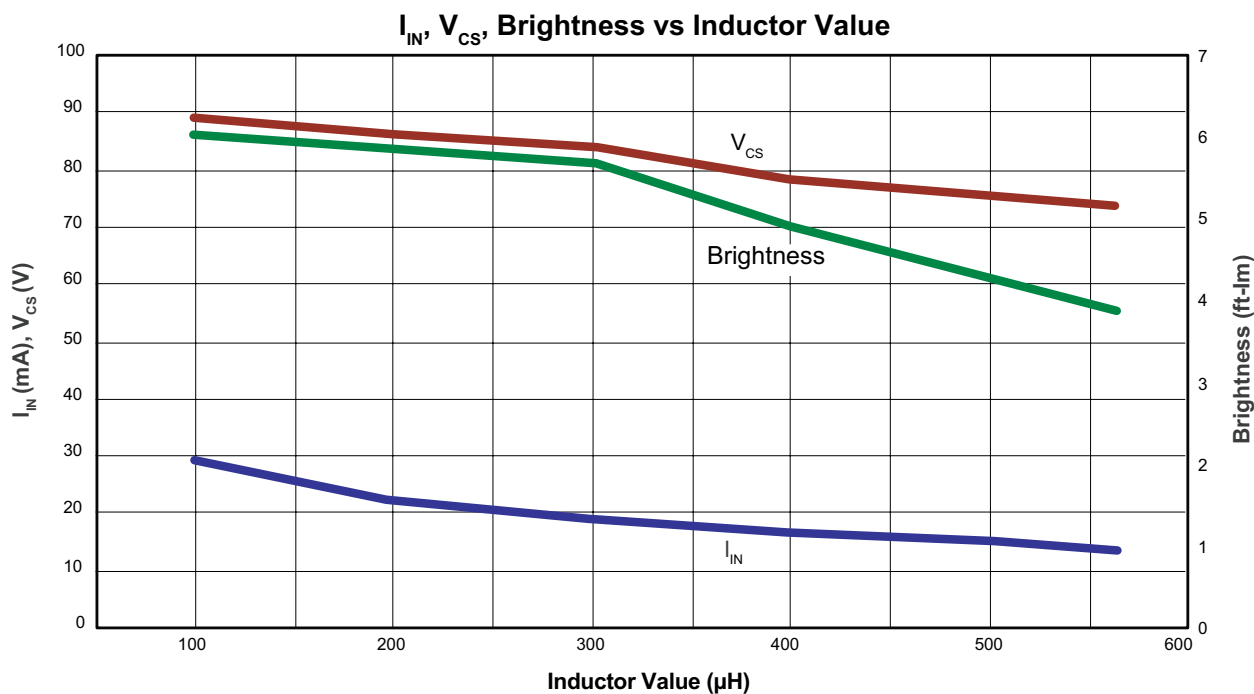
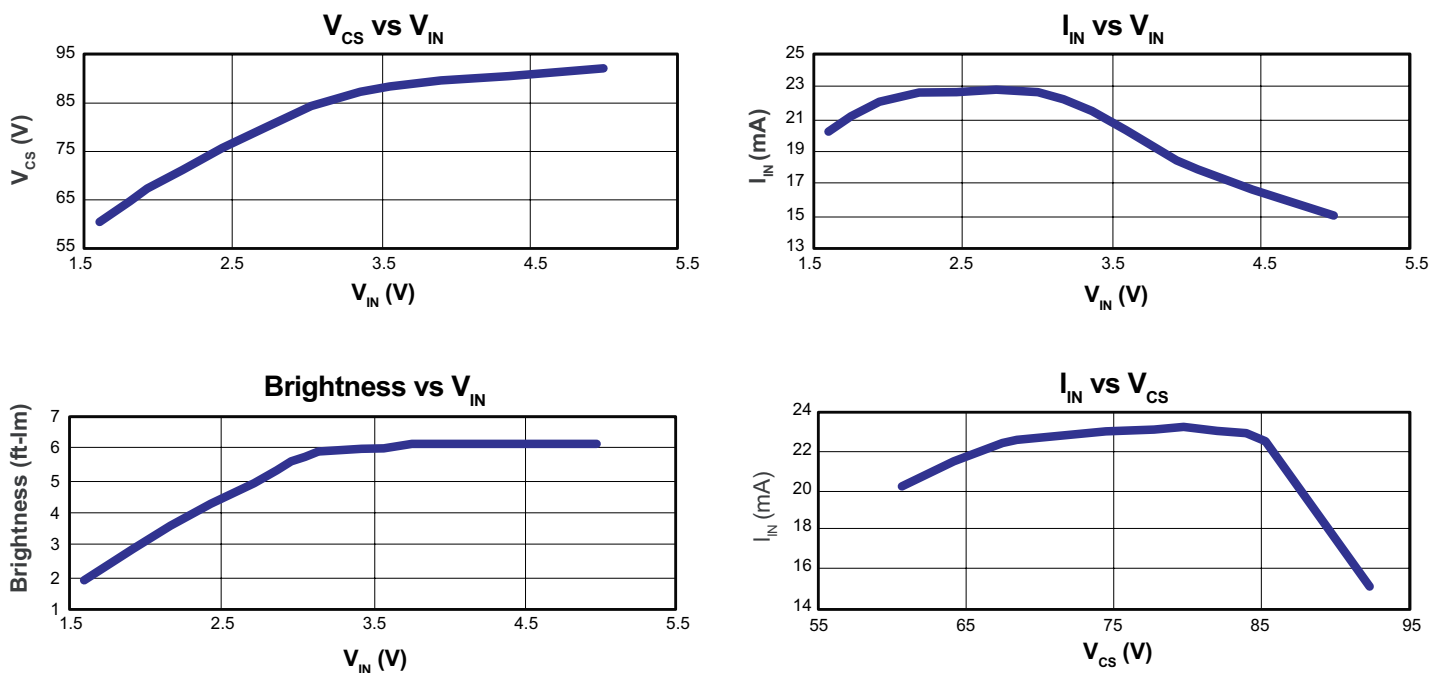

External Component Description

External Component	Description
Diode	Fast reverse recovery diode, BAS21 diode or equivalent.
C _s Capacitor	0.003μF to 0.1μF, 100V capacitor to GND is used to store the energy transferred from the inductor.
R _{EL} Resistor	<p>The EL lamp frequency is controlled via an external R_{EL} resistor connected between REL-Osc and VDD of the device. The lamp frequency increases as R_{EL} decreases. As the EL lamp frequency increases, the amount of current drawn from the battery will increase and the output voltage V_{CS} will decrease. The color of the EL lamp is dependent upon its frequency.</p> <p>A 2MΩ resistor would provide lamp frequency of 205 to 275Hz. Decreasing the R_{EL} resistor by a factor of 2 will increase the lamp frequency by a factor of 2.</p> $f_{EL} = \frac{(2M\Omega)(240Hz)}{R_{EL}}$
R _{SW} Resistor	<p>The switching frequency of the converter is controlled via an external resistor, R_{SW} between RSW-Osc and VDD of the device. The switching frequency increases as R_{SW} decreases. With a given inductor, as the switching frequency increases, the amount of current drawn from the battery will decrease and the output voltage, V_{CS}, will also decrease.</p> $f_{SW} = \frac{(560k\Omega)(80Hz)}{R_{SW}}$
L _x Inductor	<p>The inductor L_x is used to boost the low input voltage by inductive flyback. When the internal switch is on, the inductor is being charged. When the internal switch is off, the charge stored in the inductor will be transferred to the high voltage capacitor C_s. The energy stored in the capacitor is connected to the internal H-bridge, and therefore to the EL lamp. In general, smaller value inductors, which can handle more current, are more suitable to drive larger size lamps. As the inductor value decreases, the switching frequency of the inductor (controlled by R_{SW}) should be increased to avoid saturation.</p> <p>A 220μH Murata (LQH32CN221) inductor with 8.4Ω series DC resistance is typically recommended. For inductors with the same inductance value, but with lower series DC resistance, lower R_{SW} resistor value is needed to prevent high current draw and inductor saturation.</p>
Lamp	As the EL lamp size increases, more current will be drawn from the battery to maintain high voltage across the EL lamp. The input power, (V _{IN} x I _{IN}), will also increase. If the input power is greater than the power dissipation of the package, an external resistor in series with one side of the lamp is recommended to help reduce the package power dissipation.

Split Supply Configuration

The HV857 can also be used for handheld devices operating from a battery where a regulated voltage is available. This is shown in Figure 2. The regulated voltage can be used to run the internal logic of the HV857. The amount of current necessary to run the internal logic is 150µA Max at a V_{DD} of 3.0V. Therefore, the regulated voltage could easily provide the current without being loaded down.

Enable/Disable Configuration

The HV857 can be easily enabled and disabled via a logic control signal on the R_{SW} and R_{EL} resistors as shown in Figure 2 below. The control signal can be from a microprocessor. The control signal has to track the V_{DD} supply. R_{SW} and R_{EL} are typically very high values. Therefore, only 10's of microamperes will be drawn from the logic signal when it is at a logic high (enable) state. When the microprocessor signal is high the device is enabled, and when the signal is low, it is disabled.

Figure 2: Split Supply and Enable/Disable Configuration

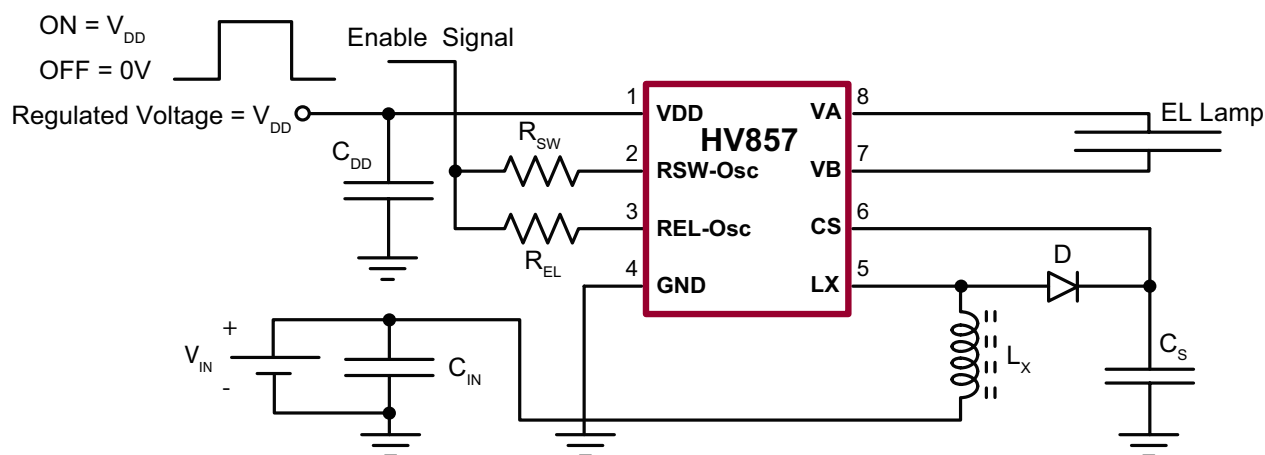

Audible Noise Reduction

This section describes a method (patented) developed at Supertex to reduce the audible noise emitted by the EL lamps used in application sensitive to audible noise. Figure

3 shows a general circuit schematic that uses the resistor, R_{SER} , connected in series with the EL lamp.

Figure 3: Typical Application Circuit for Audible Noise Reduction

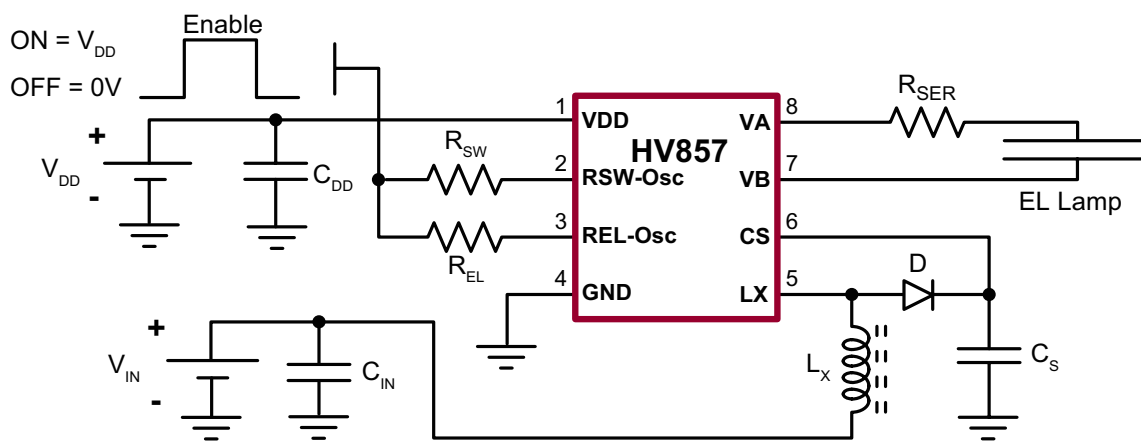

Minimization of EL Lamp Audible Noise

The EL lamp, when lit, emits an audible noise. This is due to EL lamp construction and it creates a major problem for applications where the EL lamp can be close to the ear such as cellular phones. The noisiest waveform is a square wave and the quietest waveform has been assumed to be a sine wave.

After extensive research, Supertex has developed a waveform that is quieter than a sine wave. The waveform takes the shape of approximately $2RC$ time constants for rising and $2RC$ time constants for falling, where C is the capacitance of the EL lamp, and R is the external resistor, R_{SER} , connected in series with the EL lamp. This waveform has been proven to generate less noise than a sine wave.

The audible noise from the EL lamp can be set at a desired level based on the series resistor value used with the lamp. It is important to note that use of this resistor will reduce the voltage across the lamp. Reduction of voltage across the lamp will also have another effect on the overall performance of the Supertex EL drivers, age compensation (patented). This addresses a very important issue, EL lamp life that most mobile phone manufacturers are concerned about.

Effect of Series Resistor on EL Lamp Audible Noise and Brightness

As EL lamp ages, its brightness is reduced and its capacitance is diminished. By using the RC model to reduce the audible noise emitted by the EL lamp, the voltage across the lamp will increase as its capacitance diminishes. Hence the increase in voltage will compensate for the reduction of the brightness. As a result, it will extend the EL lamp's half-life (half the original brightness).

Increasing the value of the series resistor with the lamp will reduce the EL lamp audible noise as well as its brightness. This is due to the fact that the output voltage across the lamp will be reduced and the output waveform will have rounder edges.

8-Lead DFN Package Outline (K7)

3.00x3.00mm body, 0.80mm height (max), 0.65mm pitch

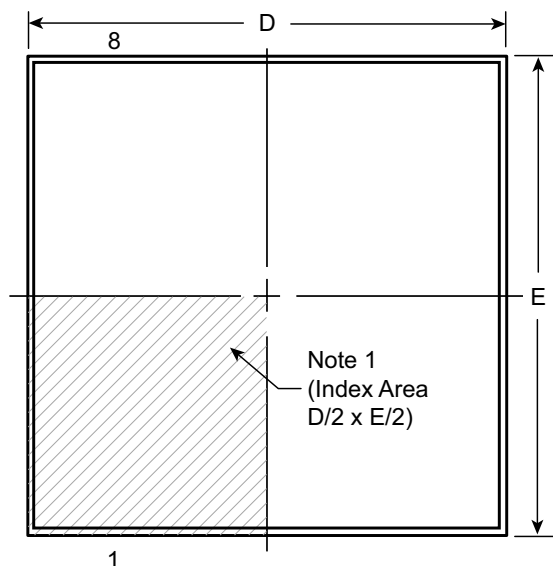

Top View

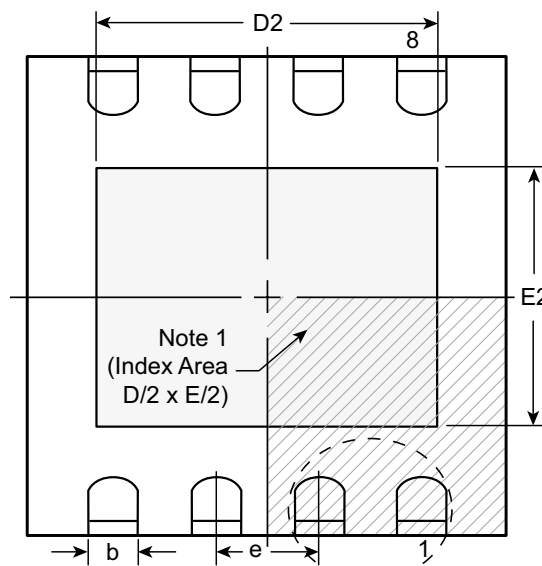

Bottom View

View B

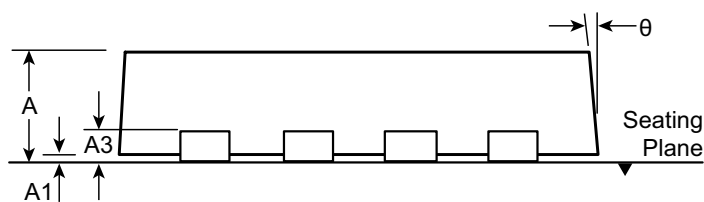

Side View

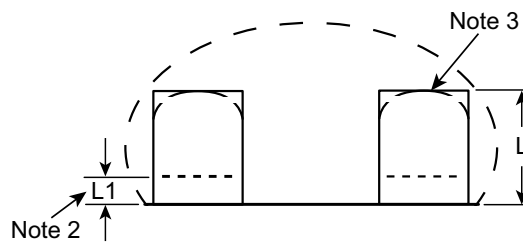

View B

Notes:

1. A Pin 1 identifier must be located in the index area indicated. The Pin 1 identifier can be: a molded mark/identifier; an embedded metal marker; or a printed indicator.
2. Depending on the method of manufacturing, a maximum of 0.15mm pullback (L1) may be present.
3. The inner tip of the lead may be either rounded or square.

Symbol	A	A1	A3	b	D	D2	E	E2	e	L	L1	θ	
Dimension (mm)	MIN	0.70	0.00	0.20 REF	0.25	2.85*	1.60	2.85*	1.35	0.65 BSC	0.30	0.00*	0°
	NOM	0.75	0.02		0.30	3.00	-	3.00	-		0.40	-	-
	MAX	0.80	0.05		0.35	3.15*	2.50	3.15*	1.75		0.50	0.15	14°

JEDEC Registration MO-229, Variation WEEC-2, Issue C, Aug. 2003.

* This dimension is not specified in the JEDEC drawing.

Drawings not to scale.

Supertex Doc. #: DSPD-8DFNK73X3P065, Version C081109.