

AR0144CS IAS Module

Prototype 1/4-inch 1.0Mp Global Shutter Module

Advance Information

IAS1MOD-AR0144CSSM080210

The AR0144 1MP IAS module is part of the ON Semiconductor IAS family of modules offering standardized connectors, layout configuration and OTPM protocol. The modules are compatible with Evaluations systems and reference designs offered by ON Semiconductor. The modules are offered from ON Semiconductor as prototype modules not meant for customer production shipments. Customer can work with On Semiconductor Distribution partners for equivalent mass production versions of these modules.

Applications

- Machine vision
- Robotics
- Smart Building
- Industrial
- Consumer

Table 1. KEY PERFORMANCE PARAMETERS

Parameter	Value
Sensor	
Sensor Part Number	AR0144CSSM28SUD20
FUNCTIONAL	
Output	Raw
CFA	Mono
Max. fps	60 fps @ 1280 x 800
Interface	2-lane MIPI
MECHANICAL	
Module size X*Y*Z(mm)	9.5 x 24.8 x 3.91
OPTICAL	
Optical Format	1/4"
Image active resolution	1280 (H) x 800 (V) = 1.0 Mp
Pixel size	3.0 μm
Focus Range	24 cm~Inf
Hyperfocal Distance	50 cm
Effective Focal Length (EFL)	2.48 mm
Lens F number	2.2
Lens Structure	4P
Diagonal Filed of View (DFOV)	84.1°
Vertical Field of View (VFOV)	51.2°
Horizontal Field of View (HFOV)	75.0°
TV distortion	$\leq 1.0\%$
ELECTRICAL	
Supply voltages	VDDIO: 1.8 V or 2.8 V VDD: 1.2 V VAA: 2.8 V



ON Semiconductor®

www.onsemi.com

EVAL BOARD USER'S MANUAL



This document contains information on a new product. Specifications and information herein are subject to change without notice.

IAS1MOD-AR0144CSSM080210

Table 1. KEY PERFORMANCE PARAMETERS

Parameter	Value
ELECTRICAL	
I2C Pull-up Resistor in Module (Note 1)	2.2k
PROGRAMMABLE STORAGE	
This module has programmable storage.	EEPROM/OTPM is programmed per IAS programming specifications. Please refer to the IAS Module EEPROM and OTPM Application note (AND9865/D) for more information.

1. ON Semiconductor recommends that host sites add a 1.5K pull-up resistor.

Table 2. ORDERING INFORMATION

Part Number	Orderable Product Attribute Description
IAS1MOD-AR0144CSSM080210-GEVB	AR0144 1MP 1/4" Mono 28° CRA Die in IAS module with 84.1° DFOV Lens
IAS1-ADPTR-DM3D1-GEVB	Adapter Board to Demo3, DevWareX Supported

Table 3. MODULE CONNECTOR PINOUT

Pin Number	Pin Name	Pin Number	Pin Name
1	VPP	34	SADDR
2	GND	33	GND
3	GND	32	EXTCLK
4	DATA_1P	31	GND
5	DATA_1N	30	DATA_2P
6	GND	29	DATA_2N
7	CLK_P	28	GND
8	CLK_N	27	NC
9	GND	26	NC
10	NC	25	GND
11	NC	24	VDD
12	GND	23	VDD
13	VDDIO	22	SDATA
14	SCLK	21	RESET
15	FLASH	20	TRIGGER
16	GND	19	GND
17	VAA	18	VAA

IAS1MOD-AR0144CSSM080210

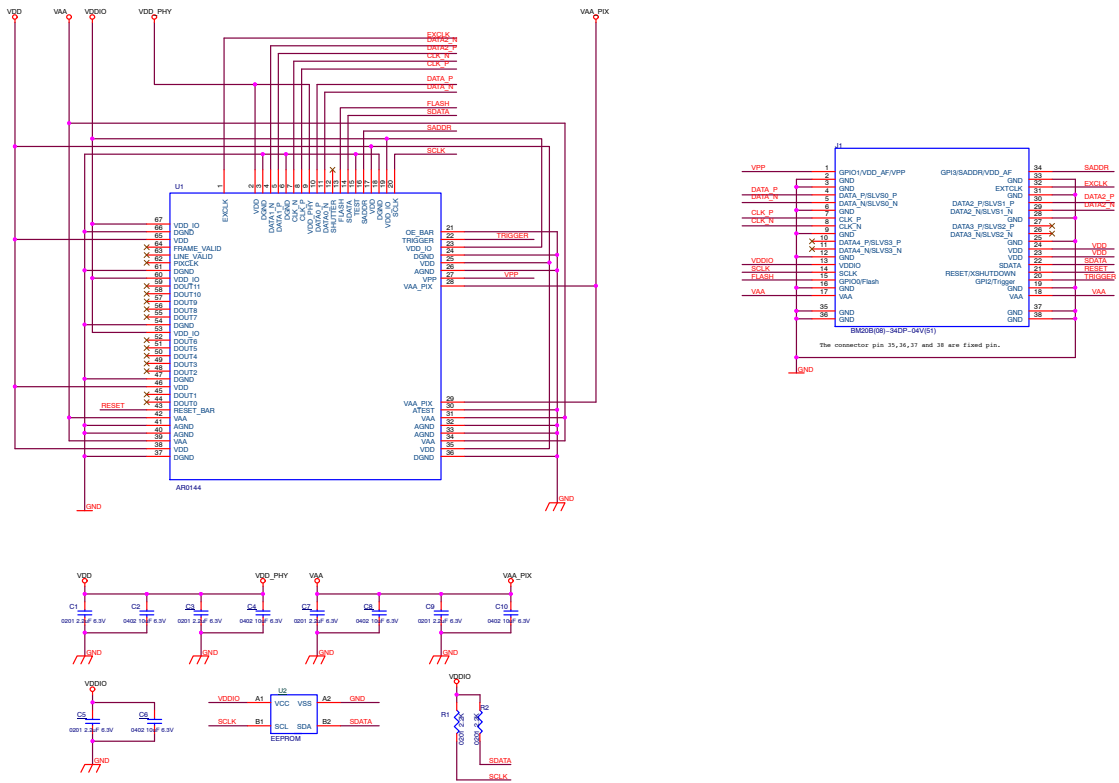

Figure 1. Typical Connections

IAS1MOD-AR0144CSSM080210

MODULE CONNECTOR

Part Number	Number of Pins	A	B	C
BM20B(0.8)-34DP-0.4V(51)	34	9.28	6.4	8.82

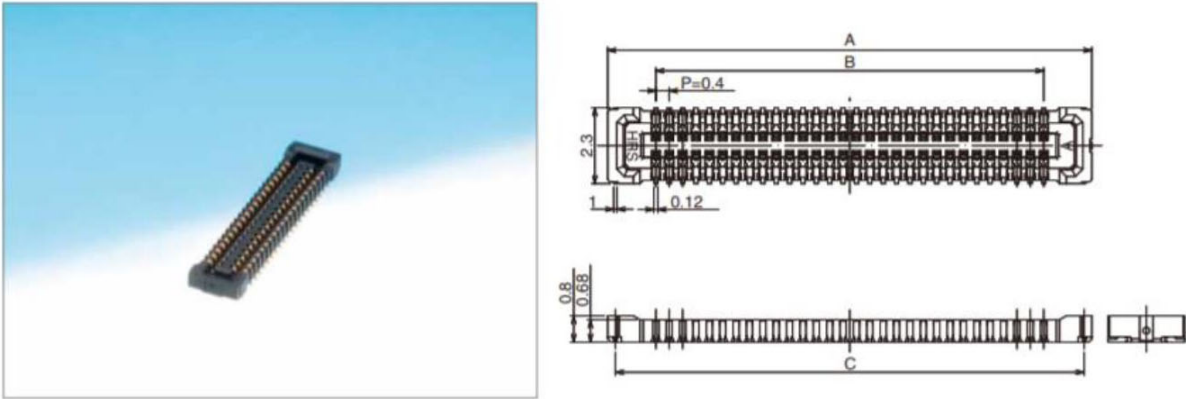
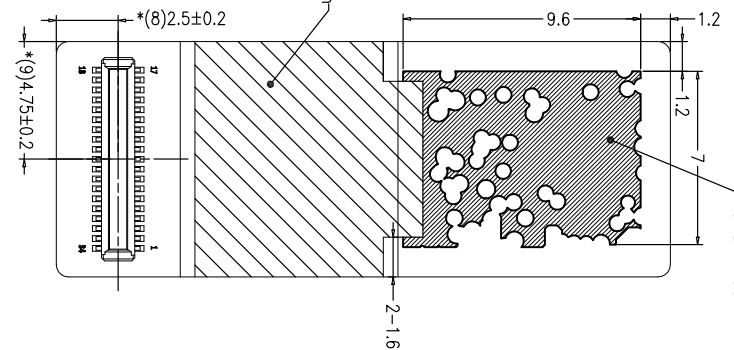
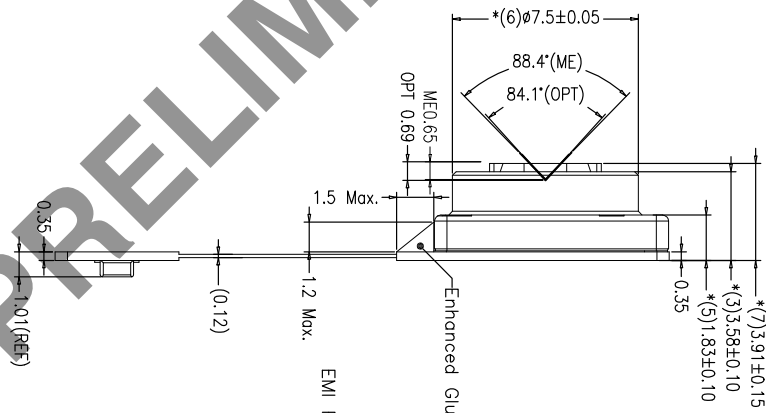
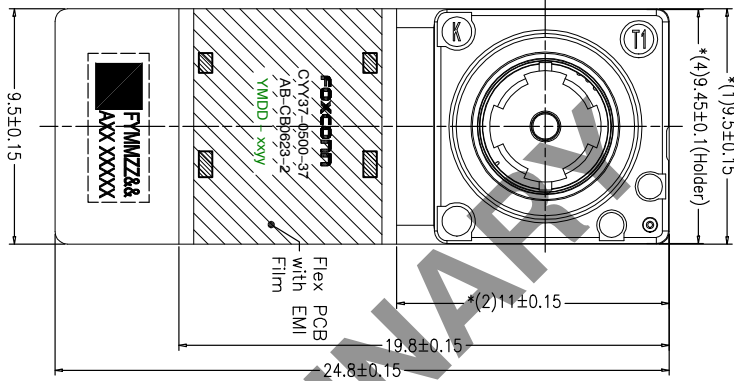
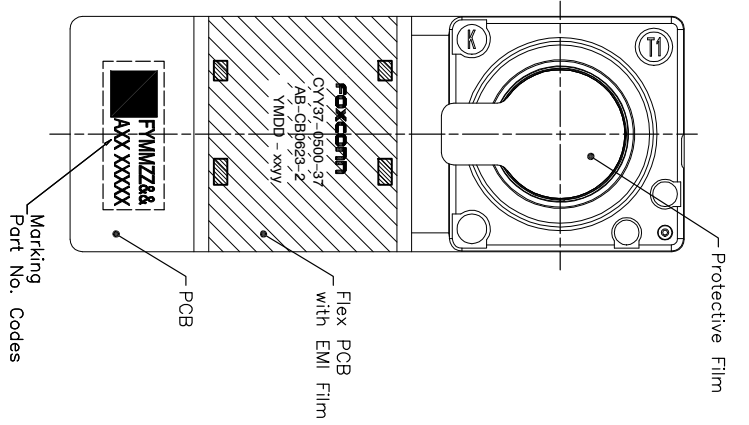

Figure 2.

MECHANICAL DIMENSIONS



NOTES:

1. SYMBOL * () IS THE CRITICAL DIMENSION.
2. THE FPCB FINGER DIMENSIONS FOLLOW CONNECTOR SPECIFICATION.
3. CONNECTOR: HRS BM20B(0.8)-34DP-0.4V(51)
4. SENSOR: ON SEMICONDUCTOR AR-0144CS 1M HD MONO.
5. LENS: EP-D432-F05