

ICL7116/ICL7117

3½ Digit ADCs with Display Hold

General Description

The Maxim ICL7116 and ICL7117 are 3½ digit monolithic analog-to-digital converters. They differ from the Maxim ICL7106 and ICL7107 in that the ICL7116 and ICL7117 have a Hold pin, which makes it possible to hold or “freeze” a reading. These integrating ADCs have very high input impedances and directly drive LCD (ICL7116) and LED (ICL7117) displays.

Versatility and accuracy are inherent features of these converters. The dual-slope conversion technique automatically rejects interference signals common in industrial environments. The true differential input is particularly useful when making ratiometric measurements (ohms or bridge transducers). Maxim has added a zero-integrator phase to the ICL7116 and ICL7117, eliminating overrange hangover and hysteresis effects. Finally, these devices offer high accuracy by lowering rollover error to less than one count and zero reading drift to less than $1\mu\text{V}/^\circ\text{C}$.

Applications

These devices can be used in a wide range of digital panel meter applications. Most applications, however, involve the measurement and display of analog data:

- Pressure
- Voltage
- Resistance
- Temperature
- Conductance
- Current
- Speed
- Material Thickness

Typical Operating Circuit

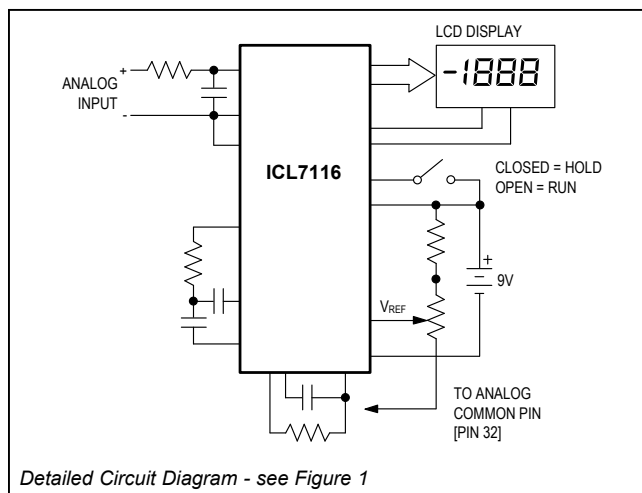

Features

- Improved 2nd Source!
- Hold Pin Allows Indefinite Display Hold
- Guaranteed First Reading Recovery from Overrange
- On-Board Display Drive Capability—No External Circuitry Required: LCD (ICL7116), LED (ICL7117)
- High-Impedance CMOS Differential Inputs
- Low Noise ($< 15\mu\text{V}_{\text{P-P}}$) Without Hysteresis or Overrange Hangover
- Clock and Reference On-Chip
- Zero Input Gives Zero Reading
- True Polarity Indication for Precision Null Applications

Ordering Information appears at end of data sheet.

Pin Configurations

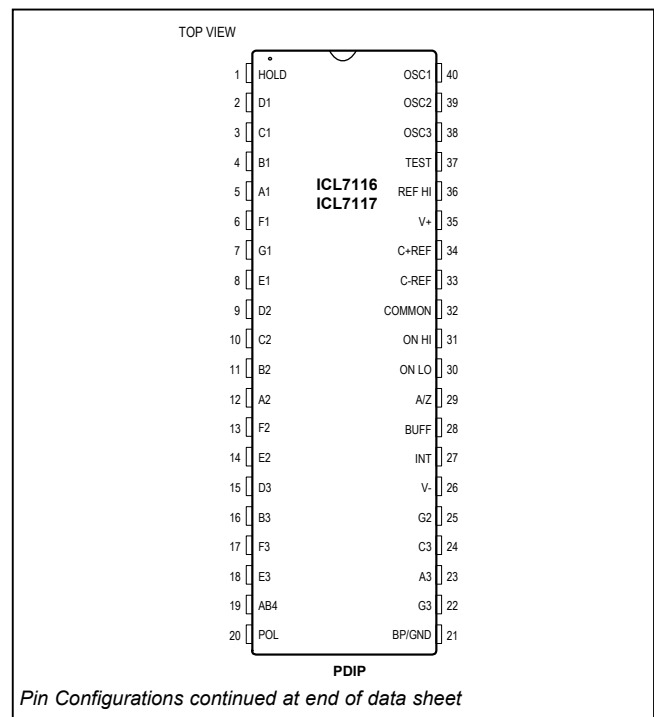

Absolute Maximum Ratings

Supply Voltage		Power Dissipation (Note 2)	
ICL7116, V+ to V-	15V	Ceramic Package	1000mW
ICL7117, V+ to GND	+6V	CERDIP Package	800mW
ICL7117, V- to GND	-9V	Plastic Package	800mW
Analog Input Voltage (either input) (Note 1).....	V+ to V-	Operating Temperature Range.....	0°C to +70°C
Reference Input Voltage (either input).....	V+ to V-	Storage Temperature Range	-65°C to +160°C
Clock Input		Lead Temperature (soldering, 60s)	+300°C
ICL7116	Test to V+		
ICL7117	GND to V+		

Note 1: Input voltage may exceed supply voltages, provided the input current is limited to 100µA.
Note 2: Dissipation rating assumes device is mounted with all leads soldered to the PCB.

Stresses beyond those listed under "Absolute Maximum Ratings" may cause permanent damage to the device. These are stress ratings only, and functional operation of the device at these or any other conditions beyond those indicated in the operational sections of the specifications is not implied. Exposure to absolute maximum rating conditions for extended periods may affect device reliability.

Electrical Characteristics (Note 3)

PARAMETER	CONDITIONS	MIN	TYP	MAX	UNITS
Zero Input Reading	V _{IN} = 0V Full Scale = 200.00mV	-000.0	±000.0	+000.0	Digital Reading
Ratiometric Reading	V _{IN} = V _{REF} = 100mV	999	999/ 1000	1000	Digital Reading
Rollover Error (Difference in Reading for Equal Positive and Negative Reading Near Full Scale)	-V _{IN} = +V _{IN} = 200mV	-1	±0.2	+1	Counts
Linearity (Max. Deviation from Best Straight Line Fit)	Full Scale = 200mV or Full Scale = 2.00mV	-1	±0.2	+1	Counts
Common-Mode Rejection Ratio (Note 4)	V _{CM} = 1V, V _{IN} = 0V Full Scale = 200.00mV	50			µV/V
Noise (Pk-Pk Value Not Exceeded 95% of the Time)	V _{IN} = 0V Full Scale = 200.00mV		15		µV
Leakage Current at Input	V _{IN} = 0V		1	10	pA
Zero Reading Drift	V _{IN} = 0V, 0°C < T _A < 70°C		0.2	1	µV/°C
Scale Factor Temperature Coefficient	V _{IN} = 199.0mV 0°C < T _A < 70°C (Ext. Ref. 0ppm/°C)		1	5	ppm/°C
V+ Supply Current (Does Not Include LED Current for ICL7117)	V _{IN} = 0V		0.8	1.8	mA
V- Supply Current for ICL7117 Only			0.6	1.8	mA
Analog Common Voltage (With Respect to Positive Supply)	25Ω Between Common and Positive Supply	2.4	2.8	3.2	V
Temperature Coefficient of Analog Common (With Respect to Pos. Supply)	25Ω Between Common and Positive Supply		80		ppm/°C
Input Resistance, Pin 1 (Note 6)		30	70		kΩ
V _{IL} , Pin 1 (ICL7116 Only)			TEST – 1.5		V

Electrical Characteristics (continued) (Note 3)

PARAMETER	CONDITIONS	MIN	TYP	MAX	
V _{IL} , Pin 1 (ICL7117 Only)			GND +1.5	V	
V _{IH} , Pin 1 (Both)		V+ - 1.5		V	
ICL7116 Only (Note 5) Pk-Pk Segment Drive Voltage, Pk-Pk Backplane Drive Voltage	V+ to V- = 9V	4	5	6	V
		4	5	6	
ICL7117 Only (Except Pin 19) Segment Sinking Current	V+ = 5.0V Segment Voltage = 3V	5	8.0	mA	
(Pin 19 Only)		10	16		

Note 3: Unless otherwise noted, specifications apply to both the ICL7116 and ICL7117 at T_A = +25°C, f_{CLOCK} = 48kHz. ICL7116 is tested in the circuit of [Figure 1](#). ICL7117 is tested in the circuit of [Figure 2](#).

Note 4: Refer to “Differential input” discussion (see Maxim’s ICL7106/ICL7107 data sheet).

Note 5: Backplane drive is in phase with segment drive for ‘off’ segment, 180° out of phase for on segment. Frequency is 20 times the conversion rate. Average DC component is less than 50mV.

Note 6: The ICL7116 logic input has an internal pulldown resistor connected from HLDR, pin 1, to TEST, pin 37. The ICL7117 logic input has an internal pulldown resistor connected from HLDR, Pin 1, to GROUND, pin 21.

Maxim Advantages

- Guaranteed Overload Recovery Time
- Significantly Improved ESD Protection (Note 8)
- Low Noise
- Key Parameters Guaranteed Over Temperature
- Negligible Hysteresis
- Maxim Quality and Reliability
- Increased Maximum Rating for Input Current (Note 9)

Absolute Maximum Ratings

This device conforms to the Absolute Maximum Ratings on adjacent page.

Electrical Characteristics

(Specifications below satisfy or exceed all ‘tested’ parameters on adjacent page V+ = 9V, T_A = +25°C, f_{CLOCK} = 48kHz; test circuit = [Figure 1](#) (ICL7116), [Figure 2](#) (ICL7117), unless otherwise noted.)

PARAMETER	CONDITIONS	MIN	TYP	MAX	UNITS
Zero Input Reading	V _{IN} = 0V Full Scale = 200.00mV T _A = +25°C (Note 7)	-000.0	±000.0	+000.0	Digital Reading
	0°C ≤ T _A ≤ +70°C (Note 11)	-000.0	±000.0	+000.0	
Ratiometric Reading	V _{IN} = V _{REF} = 100mV T _A = +25°C (Note 7)	999	999/ 1000	1000	Digital Reading
	0°C ≤ T _A ≤ +70°C (Note 11)	999	999/ 1000	1001	
Rollover Error (Difference in Reading for Equal Positive and Negative Reading Near Full Scale)	-V _{IN} = +V _{IN} = 200mV T _A = +25°C (Note 7)	-1	±0.2	+1	Counts
	0°C ≤ T _A ≤ +70°C (Note 11)		±0.2		
Linearity (Max. Deviation from Best Straight Line Fit)	Full Scale = 200mV or Full Scale = 2.00mV	-1	±0.2	+1	Counts

Electrical Characteristics (continued)

Specifications below satisfy or exceed all 'tested' parameters on adjacent page $V^+ = 9V$, $T_A = +25^\circ C$, $f_{CLOCK} = 48kHz$; test circuit = [Figure 1](#) (ICL7116), [Figure 2](#) (ICL7117), unless otherwise noted.)

PARAMETER	CONDITIONS	MIN	TYP	MAX	UNITS
Common-Mode Rejection Ratio (Note 4)	$V_{CM} = \pm 1V$, $V_{IN} = 0V$ Full Scale = 200.00mV		50		$\mu V/V$
Noise (Pk-Pk Value Not Exceeded 95% of the Time)	$V_{IN} = 0V$ Full Scale = 200.00mV		15		μV
Input Leakage Current	$V_{IN} = 0V$, $T_A = +25^\circ C$ (Note 7)		1	10	μA
	$0^\circ C \leq T_A \leq +70^\circ C$		20	200	
Zero Reading Drift	$V_{IN} = 0V$, $0^\circ C \leq T_A \leq +70^\circ C$		0.2	1	$\mu V/^\circ C$
Scale Factor Temperature Coefficient	$V_{IN} = 199.0mV$ $0^\circ C \leq T_A \leq +70^\circ C$ (Ext. Ref. 0ppm/ $^\circ C$)		1	5	ppm/ $^\circ C$
V+ Supply Current (Does Not Include LED Current for ICL7117)	$V_{IN} = 0V$, $T_A = +25^\circ C$		0.8	1.8	mA
	$0^\circ C \leq T_A \leq +70^\circ C$			2	
V- Supply Current for ICL7117 Only			0.6	1.8	mA
Analog Common Voltage (With Respect to Positive Supply)	25 Ω Between Common and Positive Supply	2.4	2.8	3.2	V
Temperature Coefficient of Analog Common (With Respect to Pos. Supply)	25 Ω Between Common and Positive Supply		80		ppm/ $^\circ C$
Input Resistance, Pin 1 (Note 6)		30	70		k Ω
V_{IL} , Pin 1 (ICL7116 Only)			TEST + 1.5		V
V_{IL} , Pin 1 (ICL7117 Only)			GND + 1.5		V
V_{IH} , Pin 1 (Both)		V+ - 1.5			V
ICL7116 Only (Note 5) Pk-Pk Segment Drive Voltage, Pk-Pk Backplane Drive Voltage	V+ to V- = 9V	4	5	6	V
ICL7117 Only (Except Pin 19) Segment Sinking Current (Pin 19 Only)	V+ = 5.0V Segment Voltage = 3V	5	8.0		mA
		10	16		
ICL7116 Only – Test Pin Voltage	With respect to V+	4	5	6	V
Overload Recovery Time (Note 10)	V_{IN} changing from $\pm 10V$ to 0V		0	1	Measurement Cycles

Note 7: Test condition is V_{IN} applied between pins IN HI and IN LO i.e., 1M Ω resistor in [Figure 1](#) and [Figure 2](#).

Note 8: All pins are designed to withstand electrostatic discharge (ESD) levels in excess of 2000V (Test circuit per MIL. Std. 883C. Method 3015 2).

Note 9: Input voltages may exceed the supply voltage provided the input current is limited to $\pm 1mA$ (This revises Note 1 on the adjacent page).

Note 10: Number of measurement cycles for display to give accurate reading.

Note 11: 1M Ω resistor is removed in [Figure 1](#) and [Figure 2](#).

Detailed Description

The Maxim ICL7116 and ICL7117 3½ digit ADCs are similar to the Maxim ICL7106 and ICL7107, except for the addition of a Hold pin. For a detailed product description, package dimensions, and applications information (other than the operation of the Hold pin described below) refer to Maxim’s ICL7106 and ICL7107 data sheet

Hold Input

The Hold input is a digital input with a logic threshold approximately midway between V+ and Test (ICL7116) or V+ and Ground (ICL7117). The ICL7116/ICL7117 continuously performs conversions, independent of the Hold

input. When the Hold input is connected to V+, however, the display latch pulse is inhibited, and the the display latches are not updated. The Hold input has a 70kΩ pull-down resistor to Test (ICL7116) or Ground (ICL7117) and the Hold input will be pulled low if it is left open. When Hold is low the ICL7116/ICL7117 updates the display at the end of each conversion. The Hold input is CMOS compatible and can also be driven by a switch connected to V+ (Figure 1 and Figure 2) or by a PNP transistor.

Unlike the ICL7106 and the ICL7107, the ICL7116 and ICL7117 do not have a Reference Low input. Apply the reference voltage between Reference High (REF HI) and Common.

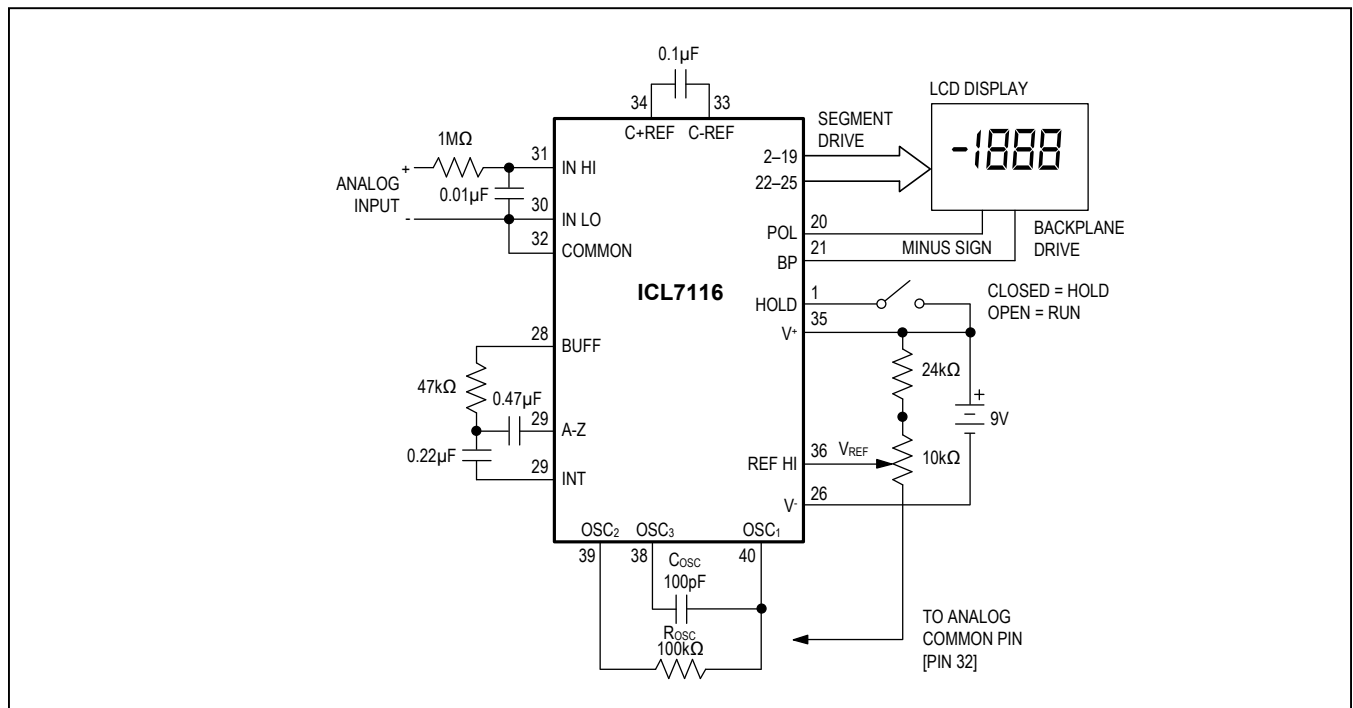

Figure 1. Maxim ICL7116 Typical Operating Circuit, 200mV Reference

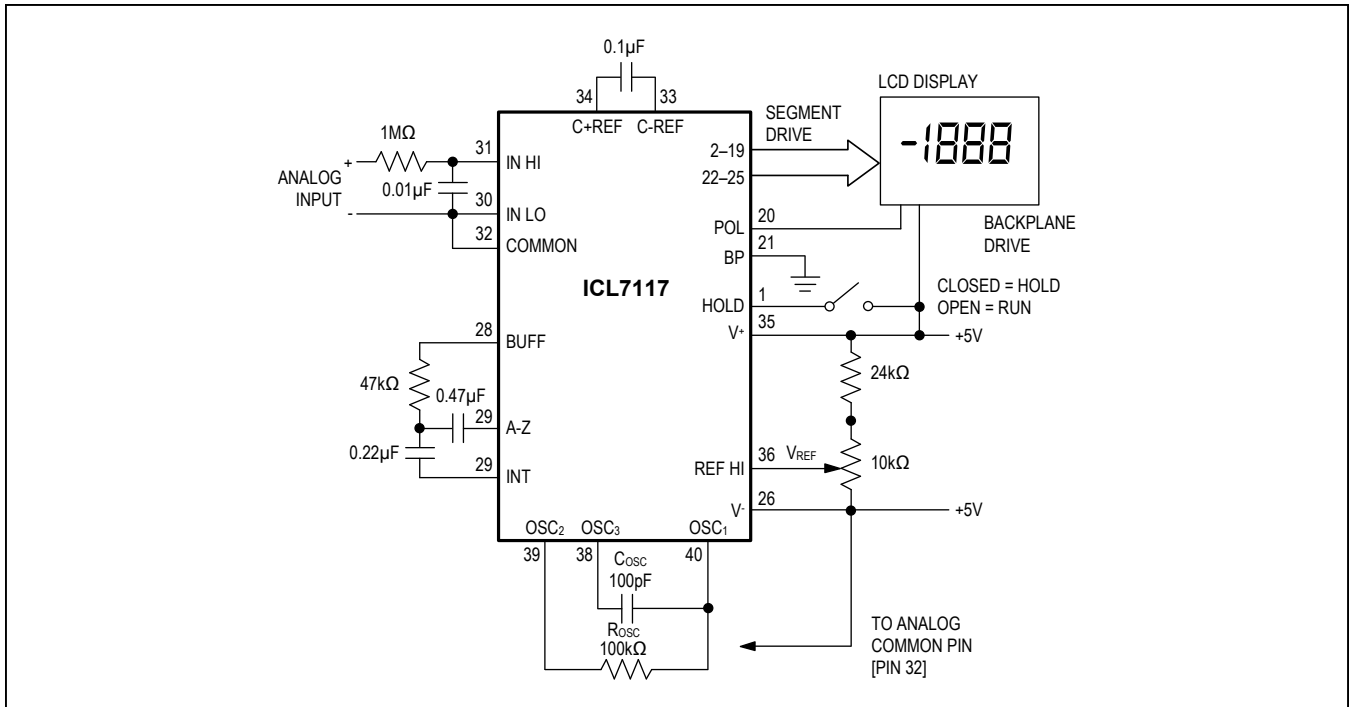
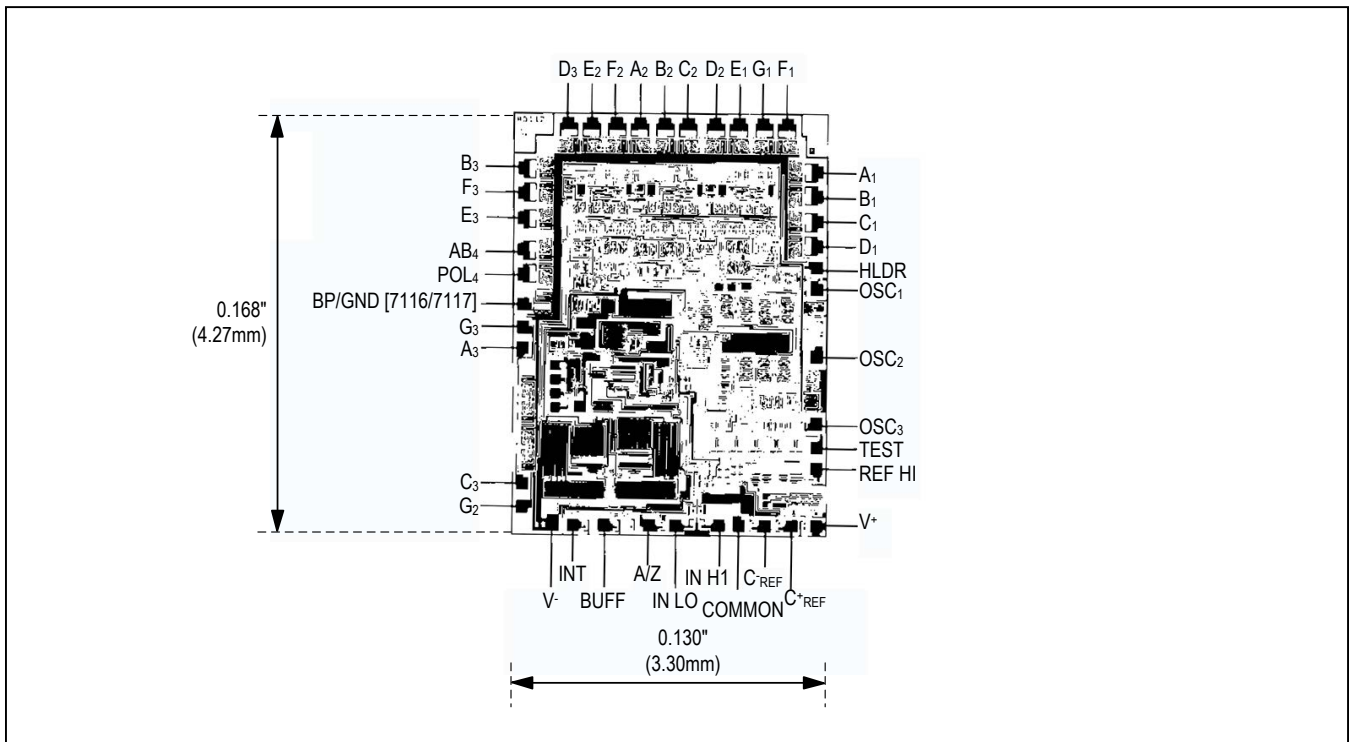
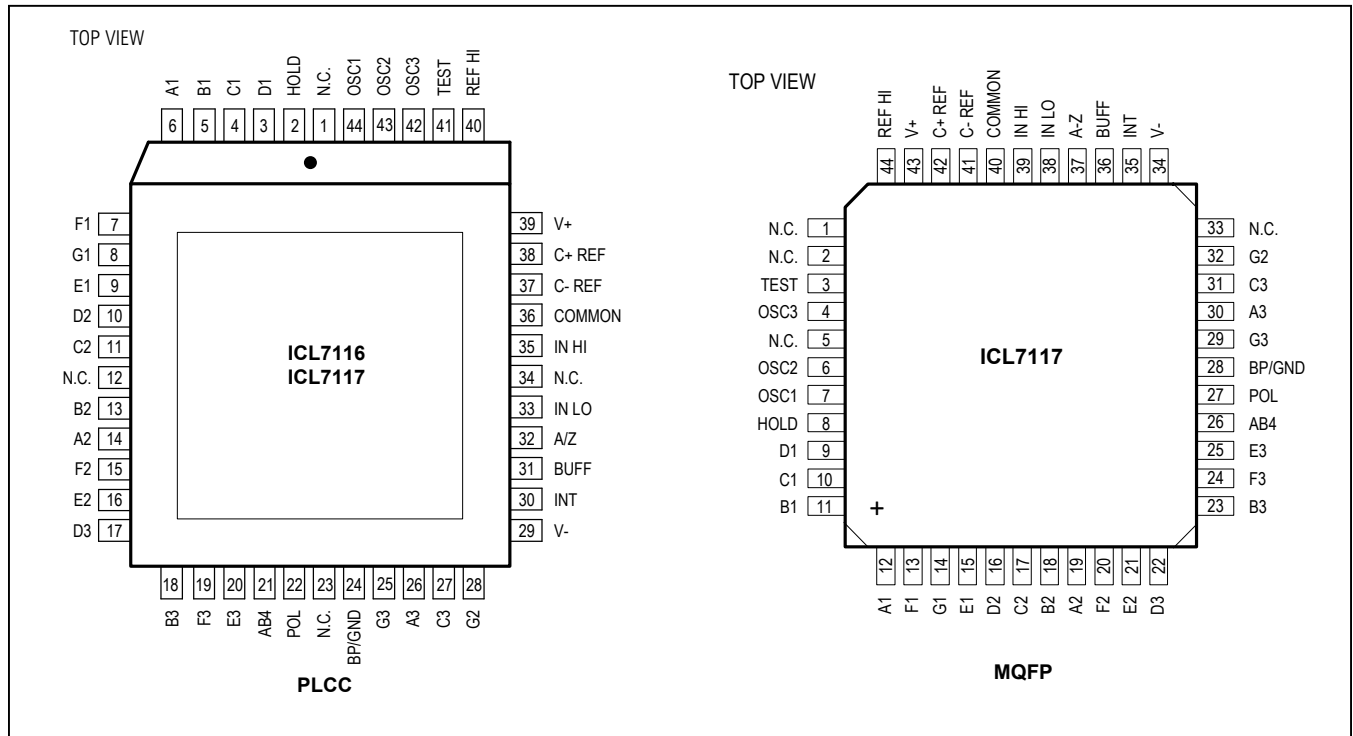

Figure 2. Maxim ICL7117 Typical Operating Circuit, 200mV Reference

Chip Topography



Pin Configurations (continued)



Ordering Information

PART	TEMP RANGE	PIN-PACKAGE
ICL7116CPL	0°C to +70°C	40 PDIP
ICL7116CJL	0°C to +70°C	40 CERDIP
ICL7116CQ	0°C to +70°C	44 LPCC
ICL7116C/D	0°C to +70°C	Dice
ICL7117CPL	0°C to +70°C	40 PDIP
ICL7117CJL	0°C to +70°C	40 CERDIP
ICL7117CMH+	0°C to +70°C	44 MQFP
ICL7117CQ	0°C to +70°C	44 LPCC
ICL7117C/D	0°C to +70°C	Dice

+Denotes lead(Pb)-free/RoHS-compliant package.

Chip Information

PROCESS: CMOS