

Analog MEMS Microphone with Single Ended Output

GENERAL DESCRIPTION

The ICS-40214 is an analog MEMS microphone with very high dynamic range and single ended output. The ICS-40214 includes a MEMS microphone element, an impedance converter, and an output amplifier.

Other high-performance specifications include 128 dB SPL acoustic overload point and tight ± 1 dB sensitivity tolerance.

The ICS-40214 is available in a small 3.50 mm \times 2.65 mm \times 0.98 mm bottom port surface-mount package.

FUNCTIONAL BLOCK DIAGRAM

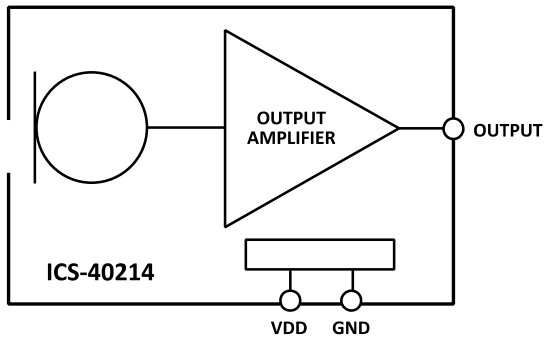

APPLICATIONS

- Smartphones
- Wearable devices
- Still and video cameras
- IoT devices

FEATURES

- Analog output
- -38 dBV sensitivity
- ± 1 dB sensitivity tolerance
- Extended frequency response from 35 Hz to 20 kHz
- -88 dB PSRR
- 3.50 \times 2.65 \times 0.98 mm surface-mount package
- Compatible with Sn/Pb and Pb-free solder processes
- RoHS/WEEE compliant

ORDERING INFORMATION

PART	TEMP RANGE	PACKAGING
ICS-40214	-40°C to $+85^{\circ}\text{C}$	13" Tape and Reel
EV_IC3-40214-FX	—	

1 TABLE OF CONTENTS

General Description 1

Functional Block Diagram 1

Applications 1

Features 1

Ordering Information 1

1 Table of Contents 2

2 Specifications 3

 2.1 Table 1. Electrical Characteristics 3

3 Absolute Maximum Ratings 4

 3.1 Table 2. Absolute Maximum Ratings 4

 3.2 ESD Caution 4

 3.3 Soldering Profile 5

 3.4 Table 3. Recommended Soldering Profile 5

4 Pin Configurations And Function Descriptions 6

 4.1 Table 4. Pin Function Descriptions 6

5 Typical Performance Characteristics 7

6 Applications Information 8

 6.1 Codec Connection 8

7 Supporting Documents 9

 7.1 Evaluation Board User Guide 9

 7.2 Application Notes 9

8 PCB Design And Land Pattern Layout 10

 8.1 PCB Material And Thickness 10

9 Handling Instructions 11

 9.1 Pick And Place Equipment 11

 9.2 Reflow Solder 11

 9.3 Board Wash 11

10 Outline Dimensions 12

 10.1 Ordering Guide 12

 10.2 Revision History 13

11 Compliance Declaration Disclaimer 14

2 SPECIFICATIONS

2.1 TABLE 1. ELECTRICAL CHARACTERISTICS

T_A = 25°C, V_{DD} = 1.65 to 3.63 V, unless otherwise noted. Typical specifications are not guaranteed.

PARAMETER	CONDITIONS	MIN	TYP	MAX	UNITS	NOTES
PERFORMANCE						
Directionality		Omni				
Output Polarity		Inverted				
Sensitivity	1 kHz, 94 dB SPL	-39	-38	-37	dBV	
Signal-to-Noise Ratio (SNR)	20 kHz bandwidth, A-weighted		66		dB	
Equivalent Input Noise (EIN)	20 kHz bandwidth, A-weighted		28		dB	
Dynamic Range	Derived from EIN and acoustic overload point		100		dB	
Total Harmonic Distortion (THD)	105 dB SPL		0.2	1	%	
Power Supply Rejection Ratio (PSRR)	1 kHz, 100 mV p-p sine wave superimposed on V _{DD} = 2.75V		-88		dB	
Power Supply Rejection (PSR)	217 Hz, 100 mVp-p square wave superimposed on V _{DD} = 2.75V		-80		dBV	
Acoustic Overload Point	10% THD		128		dB SPL	
POWER SUPPLY						
Supply Voltage (V _{DD})		1.65		3.63	V	
Supply Current (I _S)	V _{DD} = 2.75V		165	190	μA	
OUTPUT CHARACTERISTICS						
Output Impedance			190		Ω	
Output Common Mode Voltage			1.0		V	
Startup Time	Output to within ±0.5 dB of stable sensitivity		15	20	ms	
Maximum Output Voltage	128 dB SPL input		0.631		V rms	
Noise Floor	20 Hz to 20 kHz, A-weighted, rms		-104		dBV	

3 ABSOLUTE MAXIMUM RATINGS

Stress above those listed as Absolute Maximum Ratings may cause permanent damage to the device. These are stress ratings only and functional operation of the device at these conditions is not implied. Exposure to the absolute maximum ratings conditions for extended periods may affect device reliability.

3.1 TABLE 2. ABSOLUTE MAXIMUM RATINGS

PARAMETER	RATING
Supply Voltage (V _{DD})	-0.3V to +3.63V
Sound Pressure Level	160 dB
Mechanical Shock	10,000g
Vibration	Per MIL-STD-883 Method 2007, Test Condition B
Temperature Range	
Biased	-40°C to +85°C
Storage	-55°C to +150°C

3.2 ESD CAUTION



ESD (electrostatic discharge) sensitive device. Charged devices and circuit boards can discharge without detection. Although this product features patented or proprietary protection circuitry, damage may occur on devices subjected to high energy ESD. Therefore proper ESD precautions should be taken to avoid performance degradation or loss of functionality.

3.3 SOLDERING PROFILE

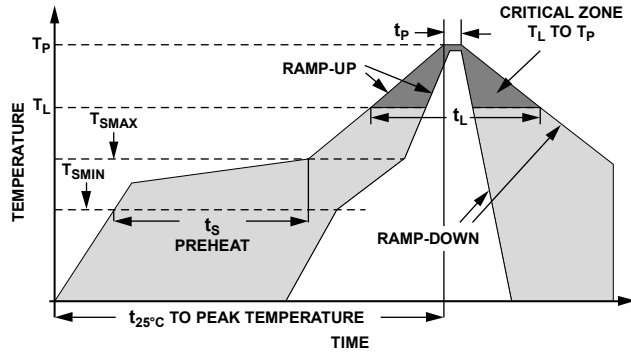

Figure 1. Recommended Soldering Profile Limits

3.4 TABLE 3. RECOMMENDED SOLDERING PROFILE

PROFILE FEATURE		SN63/PB37	PB-FREE
Average Ramp Rate (T_L to T_P)		1.25°C/sec max	1.25°C/sec max
Preheat	Minimum Temperature (T_{SMIN})	100°C	100°C
	Maximum Temperature (T_{SMAX})	150°C	200°C
	Time (T_{SMIN} to T_{SMAX}), t_s	60 sec to 75 sec	60 sec to 75 sec
Ramp-Up Rate (T_{SMAX} to T_L)		1.25°C/sec	1.25°C/sec
Time Maintained Above Liquidous (t_L)		45 sec to 75 sec	~50 sec
Liquidous Temperature (T_L)		183°C	217°C
Peak Temperature (T_P)		215°C +3°C/-3°C	260°C +0°C/-5°C
Time Within +5°C of Actual Peak Temperature (t_p)		20 sec to 30 sec	20 sec to 30 sec
Ramp-Down Rate		3°C/sec max	3°C/sec max
Time +25°C ($t_{25°C}$) to Peak Temperature		5 min max	5 min max

Note: The reflow profile in Table 3 is recommended for board manufacturing with InvenSense MEMS microphones. All microphones are also compatible with the J-STD-020 profile.

4 PIN CONFIGURATIONS AND FUNCTION DESCRIPTIONS

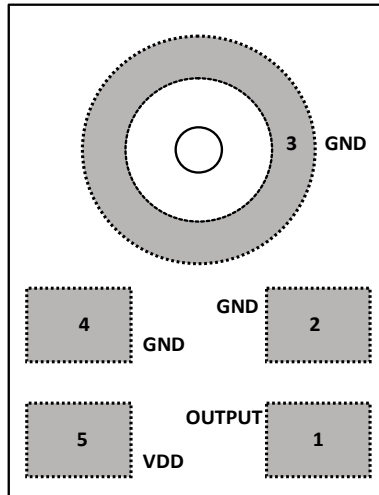

Figure 2. Pin Configuration (Top View, Terminal Side Down)

4.1 TABLE 4. PIN FUNCTION DESCRIPTIONS

PIN	NAME	FUNCTION
1	OUTPUT	Analog Output Signal
2	GND	Ground
3	GND	Ground
4	GND	Ground
5	VDD	Power Supply

5 TYPICAL PERFORMANCE CHARACTERISTICS

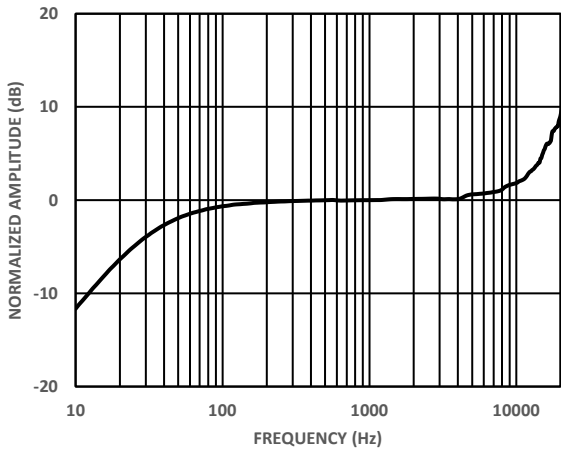

Figure 3. Typical Frequency Response (Measured)

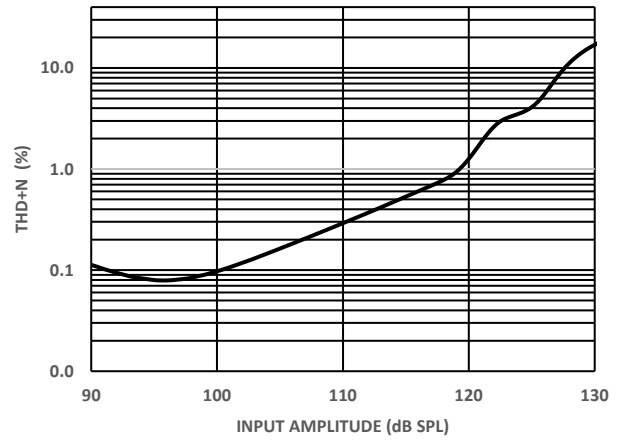

Figure 4. THD + N vs. Input Amplitude

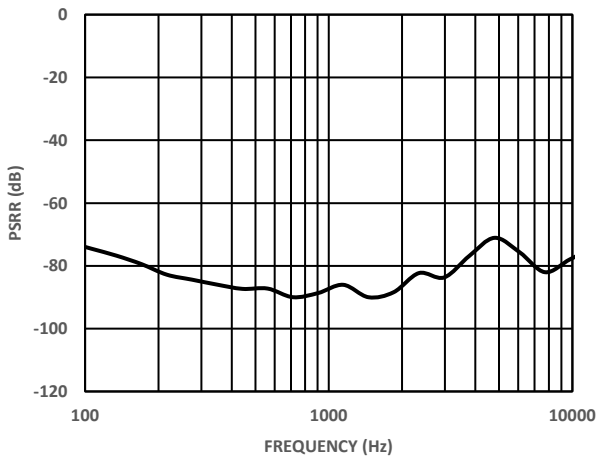

Figure 5. Power-Supply Rejection Ratio (PSRR) vs. Frequency

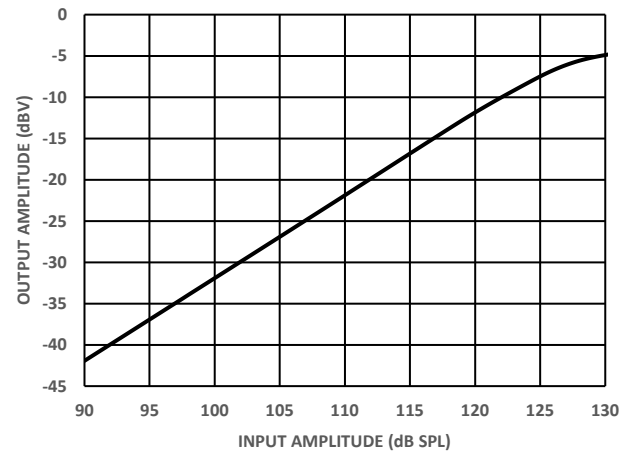

Figure 6. Linearity

6 APPLICATIONS INFORMATION

6.1 CODEC CONNECTION

The ICS-40214 output can be connected to a dedicated codec microphone input (see Figure 7) or to a high input impedance gain stage. A 0.1 μF ceramic capacitor placed close to the ICS-40214 supply pin is used for testing and is recommended to adequately decouple the microphone from noise on the power supply. A dc blocking capacitor is required at the output of the microphone. This capacitor creates a high-pass filter with a corner frequency at

$$f_c = 1/(2\pi \times C \times R)$$

where R is the input impedance of the codec.

A minimum value of 2.2 μF is recommended in Figure 7 for codecs, which may have a very low input impedance at some PGA gain settings.

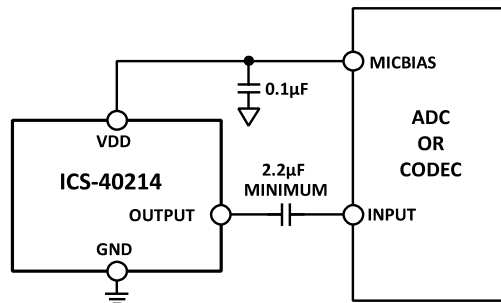

Figure 7. ICS-40214 Connected to a Codec

7 SUPPORTING DOCUMENTS

For additional information, see the following documents.

7.1 EVALUATION BOARD USER GUIDE

AN-000013, Analog Output MEMS Microphone Flex Evaluation Board

7.2 APPLICATION NOTES

AN-100, MEMS Microphone Handling and Assembly Guide

AN-1003, Recommendations for Mounting and Connecting the InvenSense Bottom-Ported MEMS Microphones

AN-1112, Microphone Specifications Explained

AN-1124, Recommendations for Sealing InvenSense Bottom-Port MEMS Microphones from Dust and Liquid Ingress

AN-1140, Microphone Array Beamforming

AN-1165, Op Amps for Microphone Preamp Circuits

AN-1181, Using a MEMS Microphone in a 2-Wire Microphone Circuit

AN-000056, MEMS Microphones for Active Noise Cancellation Applications

8 PCB DESIGN AND LAND PATTERN LAYOUT

Lay out the PCB land pattern for the ICS-40214 at a 1:1 ratio to the solder pads on the microphone package (see Figure 8.) Avoid applying solder paste to the sound hole in the PCB. Figure 9 shows a suggested solder paste stencil pattern layout.

The response of the ICS-40214 is not affected by the PCB hole size, as long as the hole is not smaller than the sound port of the microphone (0.325 mm in diameter). A 0.5 mm to 1 mm diameter for the hole is recommended.

Align the hole in the microphone package with the hole in the PCB. The exact degree of the alignment does not affect the performance of the microphone as long as the holes are not partially or completely blocked.

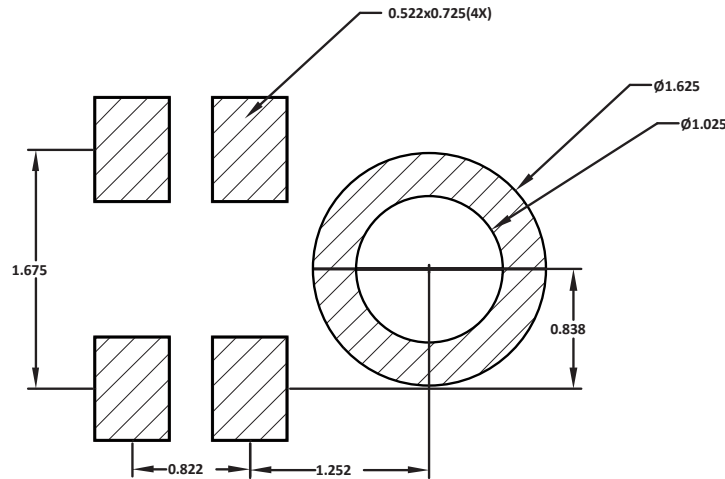

Figure 8. Recommended PCB Land Pattern Layout

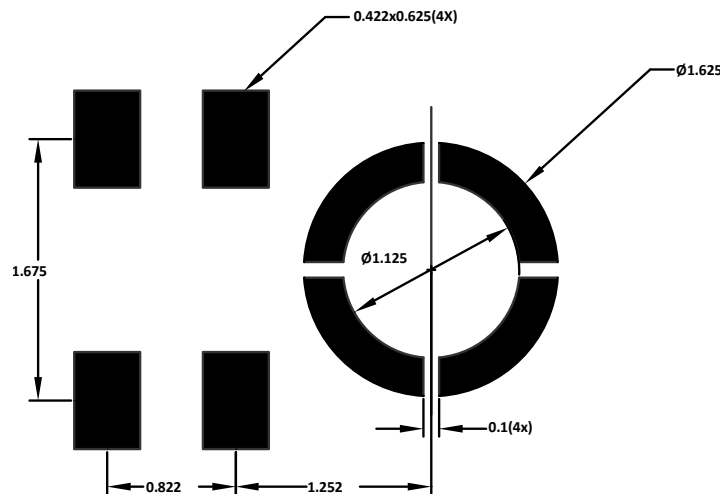

Figure 9. Recommended Solder Paste Stencil Pattern Layout

8.1 PCB MATERIAL AND THICKNESS

The performance of the ICS-40214 is not affected by PCB thickness. The ICS-40214 can be mounted on either a rigid or flexible PCB. A flexible PCB with the microphone can be attached directly to the device housing with an adhesive layer. This mounting method offers a reliable seal around the sound port while providing the shortest acoustic path for good sound quality.

9 HANDLING INSTRUCTIONS

9.1 PICK AND PLACE EQUIPMENT

The MEMS microphone can be handled using standard pick-and-place and chip shooting equipment. Take care to avoid damage to the MEMS microphone structure as follows:

- Use a standard pickup tool to handle the microphone. Because the microphone hole is on the bottom of the package, the pickup tool can make contact with any part of the lid surface.
- Do not pick up the microphone with a vacuum tool that makes contact with the bottom side of the microphone. Do not pull air out of or blow air into the microphone port.
- Do not use excessive force to place the microphone on the PCB.

9.2 REFLOW SOLDER

For best results, the soldering profile must be in accordance with the recommendations of the manufacturer of the solder paste used to attach the MEMS microphone to the PCB. It is recommended that the solder reflow profile not exceed the limit conditions specified in Figure 1 and Table 3.

9.3 BOARD WASH

When washing the PCB, ensure that water does not make contact with the microphone port. Do not use blow-off procedures or ultrasonic cleaning.

10 OUTLINE DIMENSIONS

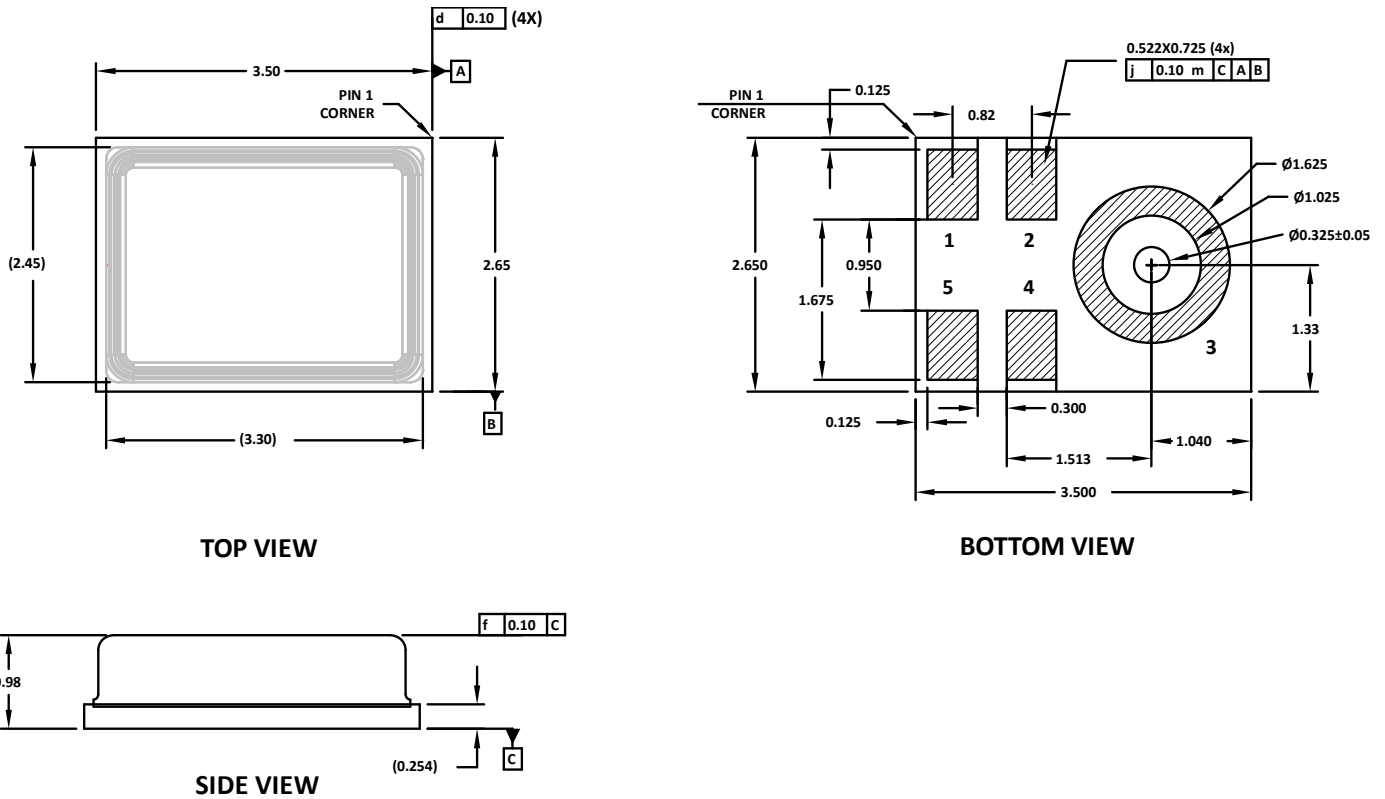

**Figure 10. 5-Terminal Chip Array Small Outline No Lead Cavity
3.50 mm × 2.65 mm × 0.98 mm Body
Dimensions shown in millimeters**

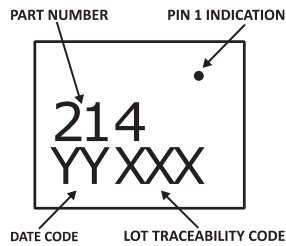

Figure 11. Package Marking Specification (Top View, not to scale)

10.1 ORDERING GUIDE

PART	TEMP RANGE	PACKAGE	QUANTITY	PACKAGING
ICS-40214	-40°C to +85°C	5-Terminal LGA_CAV	10,000	13" Tape and Reel
EV_IC3-40214-FX	—	Flexible Evaluation Board	—	