

## IGBT

High speed IGBT in Trench and Fieldstop technology

## IGW75N60H3

600V high speed switching series third generation

Data sheet

Industrial & Multimarket

## High speed IGBT in Trench and Fieldstop technology

### Features:

TRENCHSTOP™ technology offering

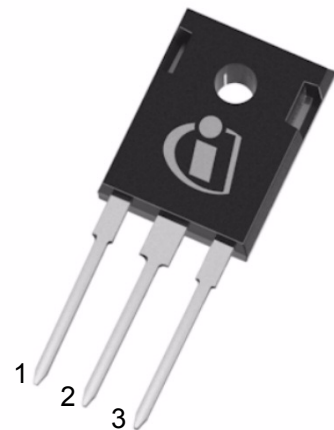
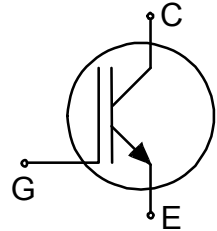
- very low  $V_{CEsat}$
- low EMI
- maximum junction temperature 175°C
- qualified according to JEDEC for target applications
- Pb-free lead plating, halogen-free mould compound, RoHS compliant
- complete product spectrum and PSpice Models:  
<http://www.infineon.com/igbt/>

### Applications:

- uninterruptible power supplies
- welding converters
- converters with high switching frequency

### Package pin definition:

- Pin 1 - gate
- Pin 2 & backside - collector
- Pin 3 - emitter



### Key Performance and Package Parameters

| Type       | $V_{CE}$ | $I_C$ | $V_{CEsat}, T_{vj}=25^{\circ}C$ | $T_{vjmax}$ | Marking | Package    |
|------------|----------|-------|---------------------------------|-------------|---------|------------|
| IGW75N60H3 | 600V     | 75A   | 1.85V                           | 175°C       | G75H603 | PG-TO247-3 |



**Table of Contents**

Description ..... 2

Table of Contents ..... 3

Maximum ratings ..... 4

Thermal Resistance ..... 4

Electrical Characteristics ..... 4

Electrical Characteristics diagrams ..... 6

Package Drawing ..... 12

Testing Conditions ..... 13

Revision History ..... 14

Disclaimer ..... 14

**Maximum ratings**

| Parameter   | Symbol      | Value         | Unit             |
|---|-------------|---------------|------------------|
| Collector-emitter voltage   | $V_{CE}$    | 600           | V                |
| DC collector current, limited by $T_{vjmax}$<br>$T_C = 25^\circ\text{C}$<br>$T_C = 100^\circ\text{C}$   | $I_C$       | 140.0<br>75.0 | A                |
| Pulsed collector current, $t_p$ limited by $T_{vjmax}$  | $I_{Cpuls}$ | 225.0         | A                |
| Turn off safe operating area $V_{CE} \leq 600\text{V}$ , $T_{vj} \leq 175^\circ\text{C}$  | -           | 225.0         | A                |
| Gate-emitter voltage  | $V_{GE}$    | $\pm 20$      | V                |
| Short circuit withstand time<br>$V_{GE} = 15.0\text{V}$ , $V_{CC} \leq 400\text{V}$<br>Allowed number of short circuits < 1000<br>Time between short circuits: $\geq 1.0\text{s}$<br>$T_{vj} = 150^\circ\text{C}$ | $t_{SC}$    | 5             | $\mu\text{s}$    |
| Power dissipation $T_C = 25^\circ\text{C}$  | $P_{tot}$   | 428.0         | W                |
| Operating junction temperature  | $T_{vj}$    | -40...+175    | $^\circ\text{C}$ |
| Storage temperature   | $T_{stg}$   | -55...+150    | $^\circ\text{C}$ |
| Soldering temperature,<br>wave soldering 1.6 mm (0.063 in.) from case for 10s   |             | 260           | $^\circ\text{C}$ |
| Mounting torque, M3 screw<br>Maximum of mounting processes: 3   | $M$         | 0.6           | Nm               |

**Thermal Resistance**

| Parameter                                   | Symbol        | Conditions | Max. Value | Unit |
|---|---------------|------------|------------|------|
| <b>Characteristic</b>                       |               |            |            |      |
| IGBT thermal resistance,<br>junction - case | $R_{th(j-c)}$ |            | 0.35       | K/W  |
| Thermal resistance<br>junction - ambient    | $R_{th(j-a)}$ |            | 40         | K/W  |

**Electrical Characteristic, at  $T_{vj} = 25^\circ\text{C}$ , unless otherwise specified**

| Parameter                            | Symbol        | Conditions  | Value       |                      |                | Unit          |
|--------------------------------------|---------------|---|-------------|----------------------|----------------|---------------|
|                                      |               |   | min.        | typ.                 | max.           |               |
| <b>Static Characteristic</b>         |               |   |             |                      |                |               |
| Collector-emitter breakdown voltage  | $V_{(BR)CES}$ | $V_{GE} = 0\text{V}$ , $I_C = 2.00\text{mA}$  | 600         | -                    | -              | V             |
| Collector-emitter saturation voltage | $V_{CEsat}$   | $V_{GE} = 15.0\text{V}$ , $I_C = 75.0\text{A}$<br>$T_{vj} = 25^\circ\text{C}$<br>$T_{vj} = 125^\circ\text{C}$<br>$T_{vj} = 175^\circ\text{C}$ | -<br>-<br>- | 1.85<br>2.10<br>2.25 | 2.30<br>-<br>- | V             |
| Gate-emitter threshold voltage       | $V_{GE(th)}$  | $I_C = 1.20\text{mA}$ , $V_{CE} = V_{GE}$   | 4.1         | 5.1                  | 5.7            | V             |
| Zero gate voltage collector current  | $I_{CES}$     | $V_{CE} = 600\text{V}$ , $V_{GE} = 0\text{V}$<br>$T_{vj} = 25^\circ\text{C}$<br>$T_{vj} = 175^\circ\text{C}$                                  | -<br>-      | -<br>-               | 40.0<br>5000.0 | $\mu\text{A}$ |
| Gate-emitter leakage current         | $I_{GES}$     | $V_{CE} = 0\text{V}$ , $V_{GE} = 20\text{V}$  | -           | -                    | 100            | nA            |
| Transconductance                     | $g_{fs}$      | $V_{CE} = 20\text{V}$ , $I_C = 75.0\text{A}$  | -           | 41.0                 | -              | S             |

**Electrical Characteristic, at  $T_{vj} = 25^{\circ}\text{C}$ , unless otherwise specified**

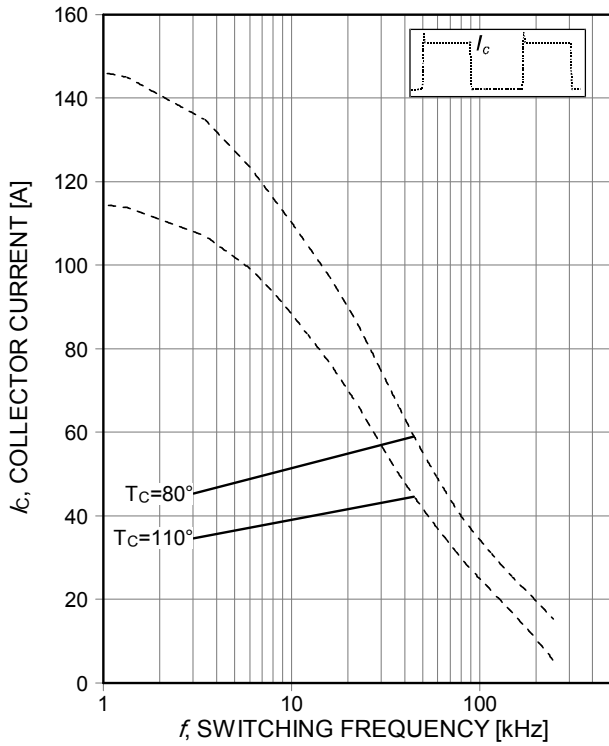
| Parameter  | Symbol      | Conditions   | Value |       |      | Unit |
|--|-------------|--|-------|-------|------|------|
|  |             |  | min.  | typ.  | max. |      |
| <b>Dynamic Characteristic</b>  |             |  |       |       |      |      |
| Input capacitance  | $C_{ies}$   | $V_{CE} = 25\text{V}, V_{GE} = 0\text{V}, f = 1\text{MHz}$   | -     | 4620  | -    | pF   |
| Output capacitance   | $C_{oes}$   |  | -     | 240   | -    |      |
| Reverse transfer capacitance   | $C_{res}$   |  | -     | 138   | -    |      |
| Gate charge  | $Q_G$       | $V_{CC} = 480\text{V}, I_C = 75.0\text{A}, V_{GE} = 15\text{V}$  | -     | 470.0 | -    | nC   |
| Internal emitter inductance measured 5mm (0.197 in.) from case   | $L_E$       |  | -     | 13.0  | -    | nH   |
| Short circuit collector current<br>Max. 1000 short circuits<br>Time between short circuits: $\geq 1.0\text{s}$ | $I_{C(SC)}$ | $V_{GE} = 15.0\text{V}, V_{CC} \leq 400\text{V}, t_{SC} \leq 5\mu\text{s}, T_{vj} = 150^{\circ}\text{C}$ | -     | 685   | -    | A    |

**Switching Characteristic, Inductive Load, at  $T_{vj} = 25^{\circ}\text{C}$** 

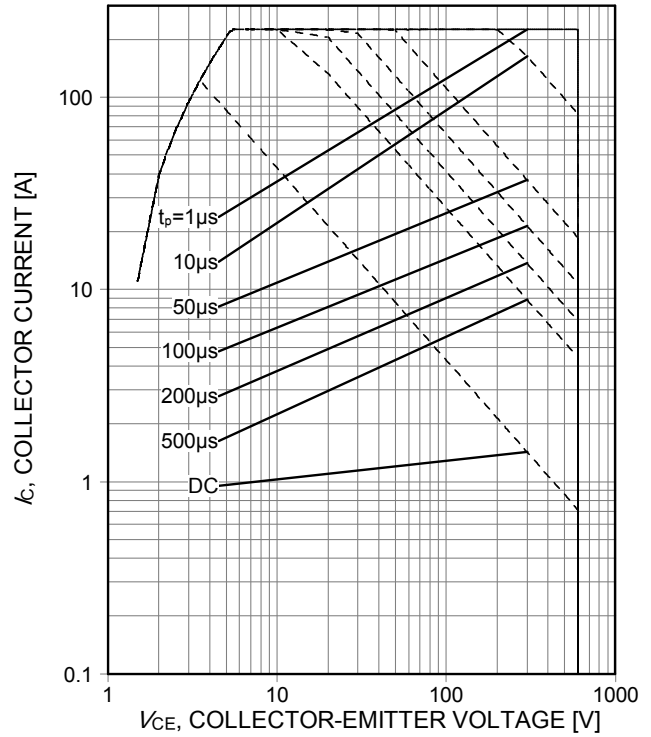
| Parameter                  | Symbol       | Conditions   | Value |      |      | Unit |
|----------------------------|--------------|--|-------|------|------|------|
|                            |              |  | min.  | typ. | max. |      |
| <b>IGBT Characteristic</b> |              |  |       |      |      |      |
| Turn-on delay time         | $t_{d(on)}$  | $T_{vj} = 25^{\circ}\text{C}, V_{CC} = 400\text{V}, I_C = 75.0\text{A}, V_{GE} = 0.0/15.0\text{V}, r_G = 5.2\Omega, L_{\sigma} = 90\text{nH}, C_{\sigma} = 50\text{pF}, L_{\sigma}, C_{\sigma}$ from Fig. E<br>Energy losses include "tail" and diode (IKW75N60H3) reverse recovery. | -     | 31   | -    | ns   |
| Rise time                  | $t_r$        |  | -     | 60   | -    | ns   |
| Turn-off delay time        | $t_{d(off)}$ |  | -     | 265  | -    | ns   |
| Fall time                  | $t_f$        |  | -     | 27   | -    | ns   |
| Turn-on energy             | $E_{on}$     |  | -     | 3.00 | -    | mJ   |
| Turn-off energy            | $E_{off}$    |  | -     | 1.70 | -    | mJ   |
| Total switching energy     | $E_{ts}$     |  | -     | 4.70 | -    | mJ   |

**Switching Characteristic, Inductive Load, at  $T_{vj} = 175^{\circ}\text{C}$** 

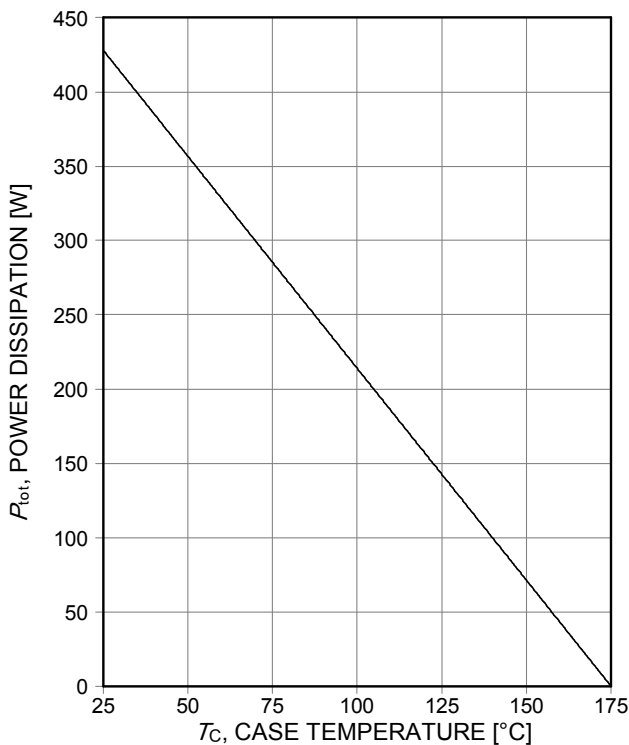
| Parameter                  | Symbol       | Conditions  | Value |      |      | Unit |
|----------------------------|--------------|---|-------|------|------|------|
|                            |              |   | min.  | typ. | max. |      |
| <b>IGBT Characteristic</b> |              |   |       |      |      |      |
| Turn-on delay time         | $t_{d(on)}$  | $T_{vj} = 175^{\circ}\text{C}, V_{CC} = 400\text{V}, I_C = 75.0\text{A}, V_{GE} = 0.0/15.0\text{V}, r_G = 5.2\Omega, L_{\sigma} = 90\text{nH}, C_{\sigma} = 50\text{pF}, L_{\sigma}, C_{\sigma}$ from Fig. E<br>Energy losses include "tail" and diode (IKW75N60H3) reverse recovery. | -     | 30   | -    | ns   |
| Rise time                  | $t_r$        |   | -     | 55   | -    | ns   |
| Turn-off delay time        | $t_{d(off)}$ |   | -     | 305  | -    | ns   |
| Fall time                  | $t_f$        |   | -     | 27   | -    | ns   |
| Turn-on energy             | $E_{on}$     |   | -     | 4.20 | -    | mJ   |
| Turn-off energy            | $E_{off}$    |   | -     | 2.00 | -    | mJ   |
| Total switching energy     | $E_{ts}$     |   | -     | 6.20 | -    | mJ   |



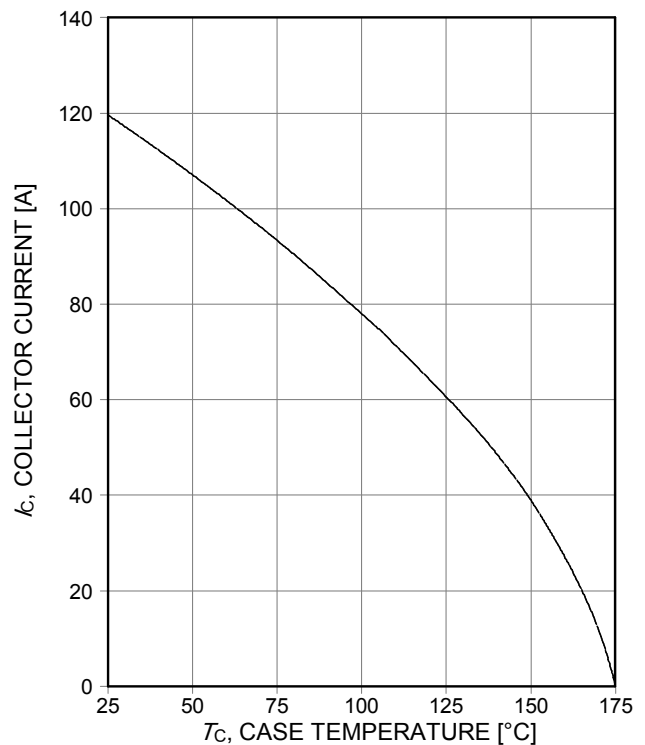
**Figure 1. Collector current as a function of switching frequency**  
 ( $T_j \leq 175^\circ\text{C}$ ,  $D=0.5$ ,  $V_{CE}=400\text{V}$ ,  $V_{GE}=15/0\text{V}$ ,  $R_G=5,2\Omega$ )



**Figure 2. Forward bias safe operating area**  
 ( $D=0$ ,  $T_C=25^\circ\text{C}$ ,  $T_j \leq 175^\circ\text{C}$ ;  $V_{GE}=15\text{V}$ )



**Figure 3. Power dissipation as a function of case temperature**  
 ( $T_j \leq 175^\circ\text{C}$ )



**Figure 4. Collector current as a function of case temperature**  
 ( $V_{GE} \geq 15\text{V}$ ,  $T_j \leq 175^\circ\text{C}$ )

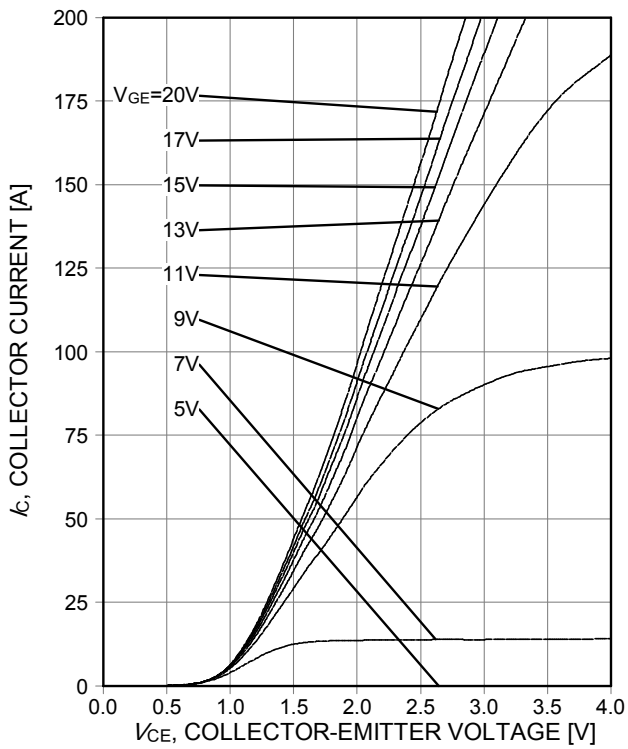


Figure 5. Typical output characteristic ( $T_j=25^\circ\text{C}$ )

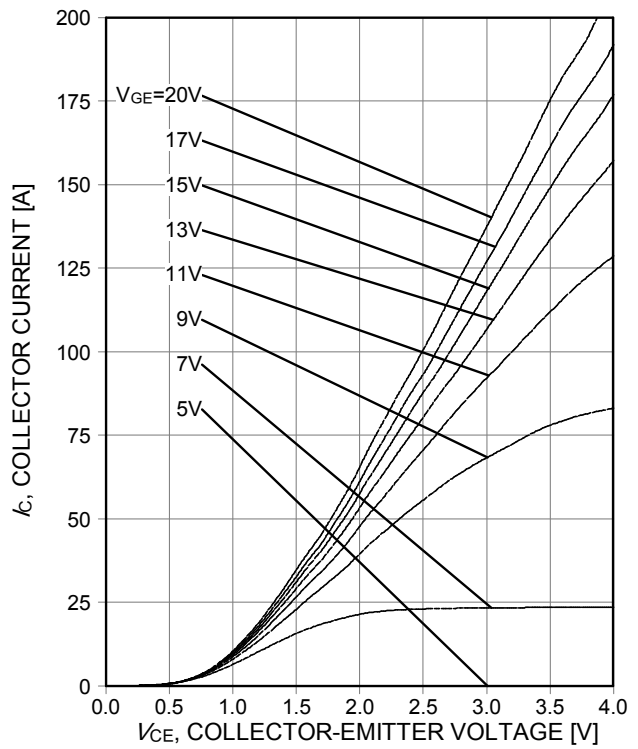


Figure 6. Typical output characteristic ( $T_j=175^\circ\text{C}$ )

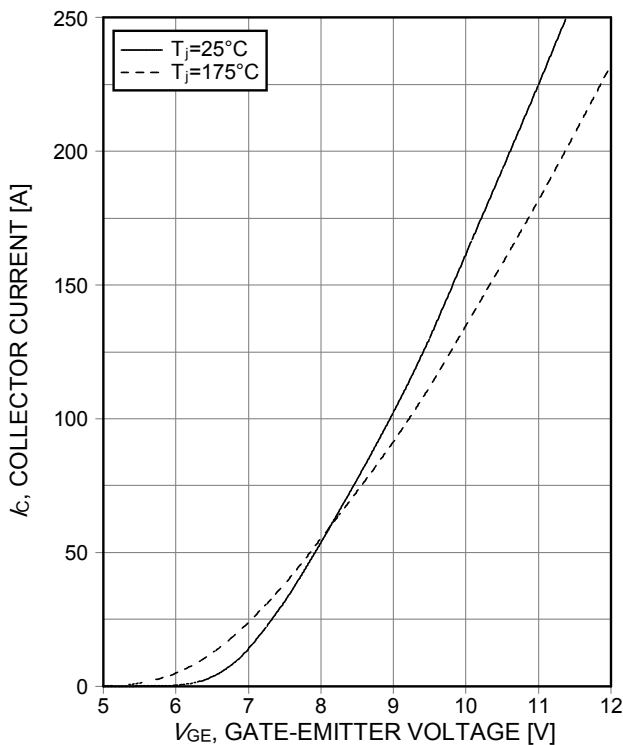


Figure 7. Typical transfer characteristic ( $V_{CE}=20\text{V}$ )

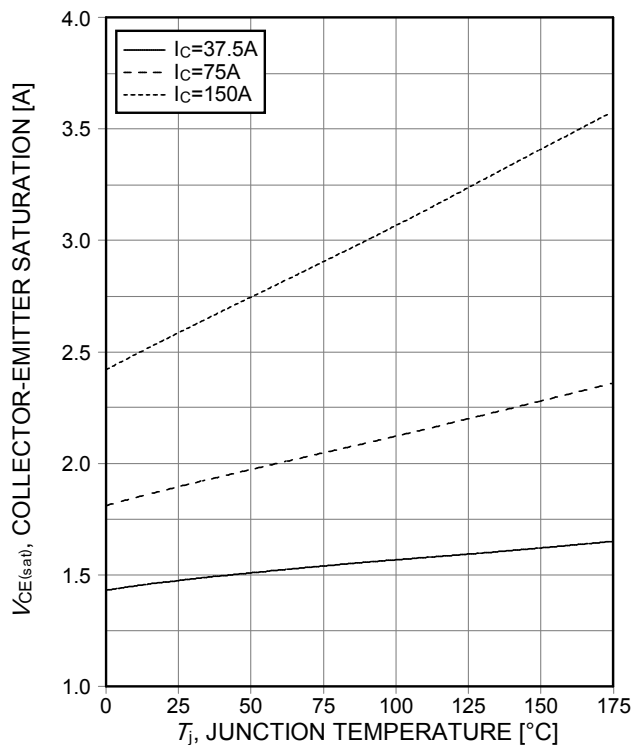
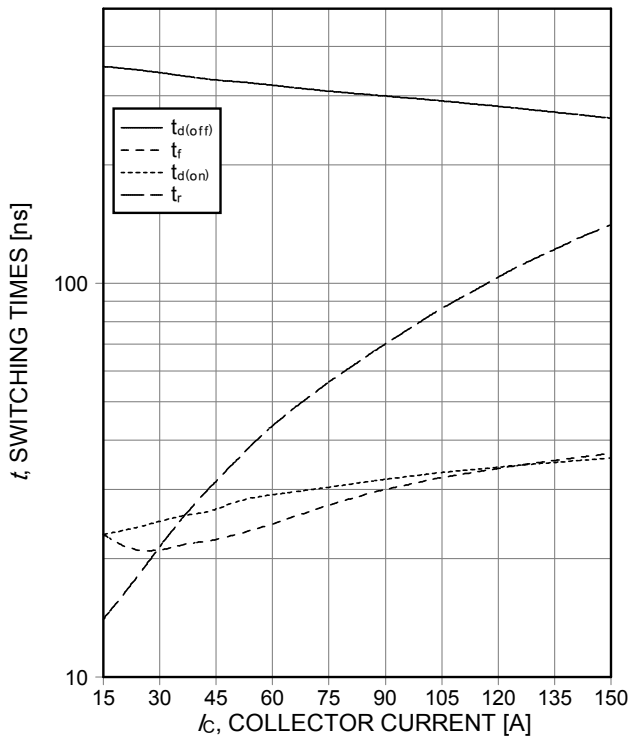
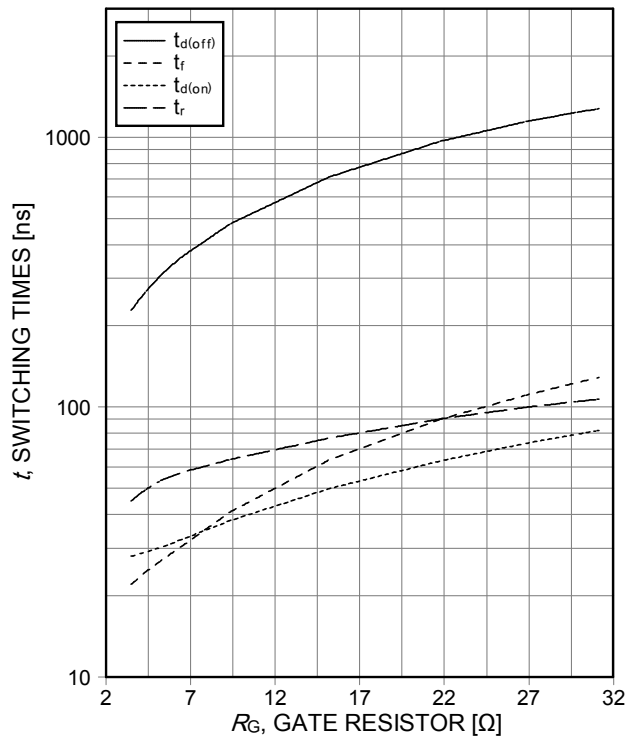


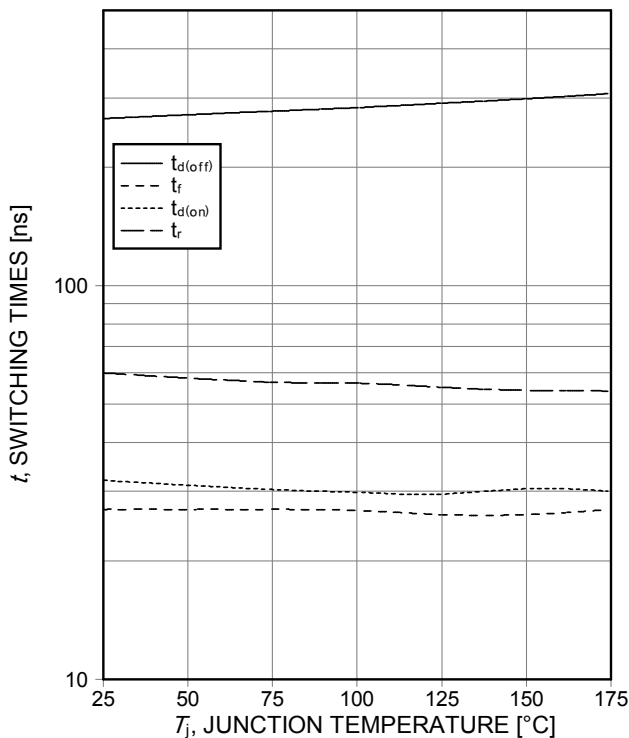
Figure 8. Typical collector-emitter saturation voltage as a function of junction temperature ( $V_{GE}=15\text{V}$ )



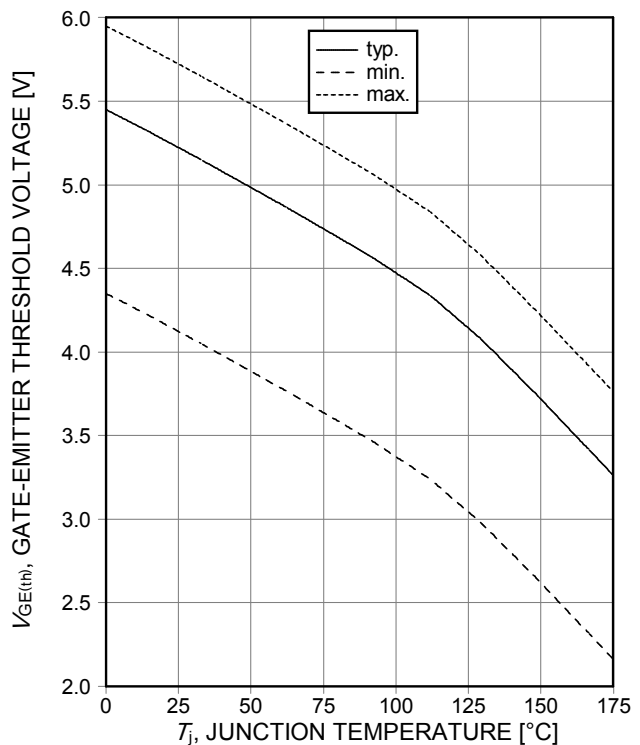
**Figure 9. Typical switching times as a function of collector current**  
 (ind. load,  $T_j=175^\circ\text{C}$ ,  $V_{CE}=400\text{V}$ ,  $V_{GE}=15/0\text{V}$ ,  $R_G=5,2\Omega$ , test circuit in Fig. E)



**Figure 10. Typical switching times as a function of gate resistor**  
 (ind. load,  $T_j=175^\circ\text{C}$ ,  $V_{CE}=400\text{V}$ ,  $V_{GE}=15/0\text{V}$ ,  $I_C=75\text{A}$ , test circuit in Fig. E)

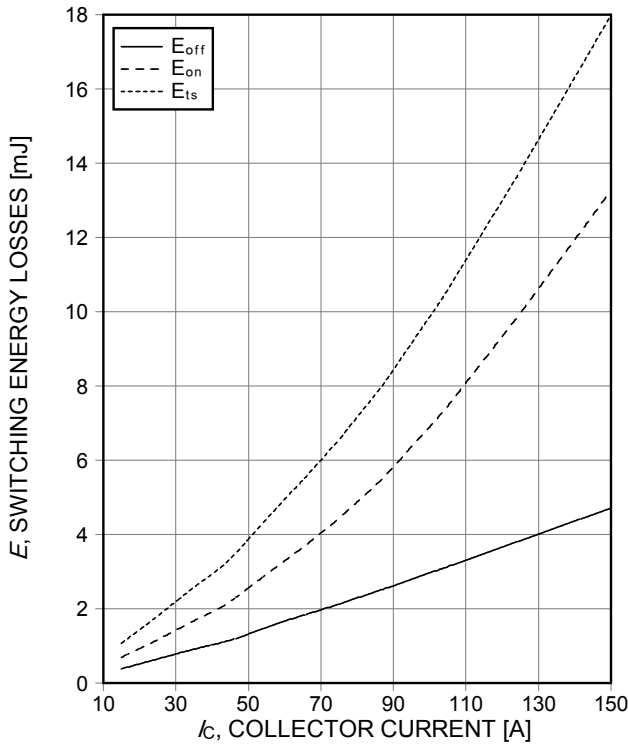


**Figure 11. Typical switching times as a function of junction temperature**  
 (ind. load,  $V_{CE}=400\text{V}$ ,  $V_{GE}=15/0\text{V}$ ,  $I_C=75\text{A}$ ,  $R_G=5,2\Omega$ , test circuit in Fig. E)

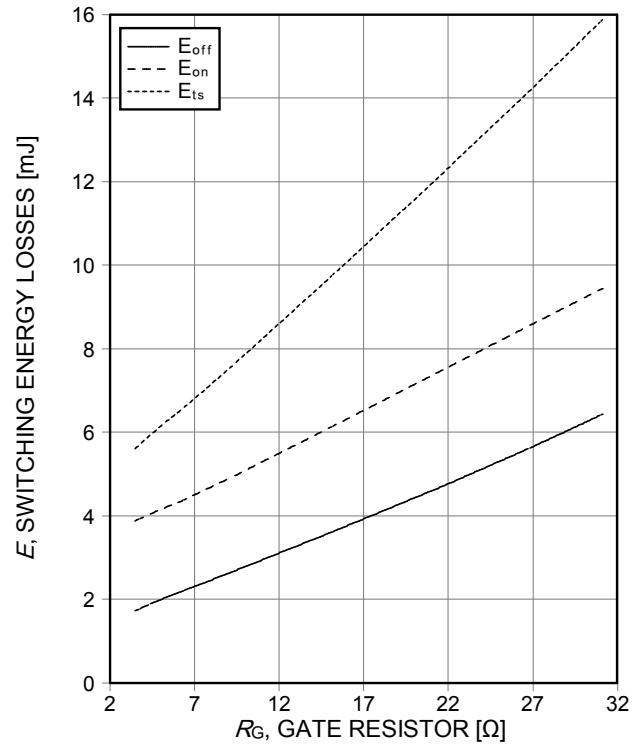


**Figure 12. Gate-emitter threshold voltage as a function of junction temperature**  
 ( $I_C=1,2\text{mA}$ )

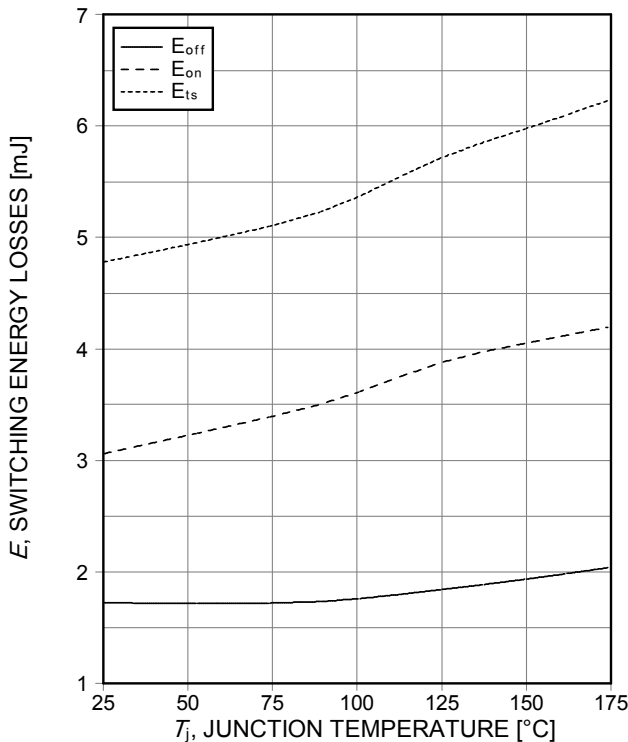




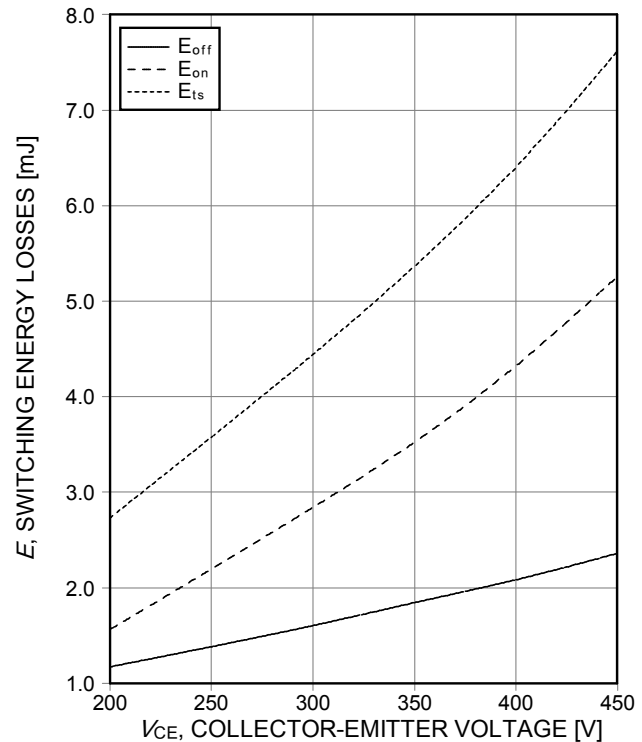
**Figure 13. Typical switching energy losses as a function of collector current**  
 (ind. load,  $T_j=175^\circ\text{C}$ ,  $V_{CE}=400\text{V}$ ,  $V_{GE}=15/0\text{V}$ ,  $R_G=5,2\Omega$ , test circuit in Fig. E)



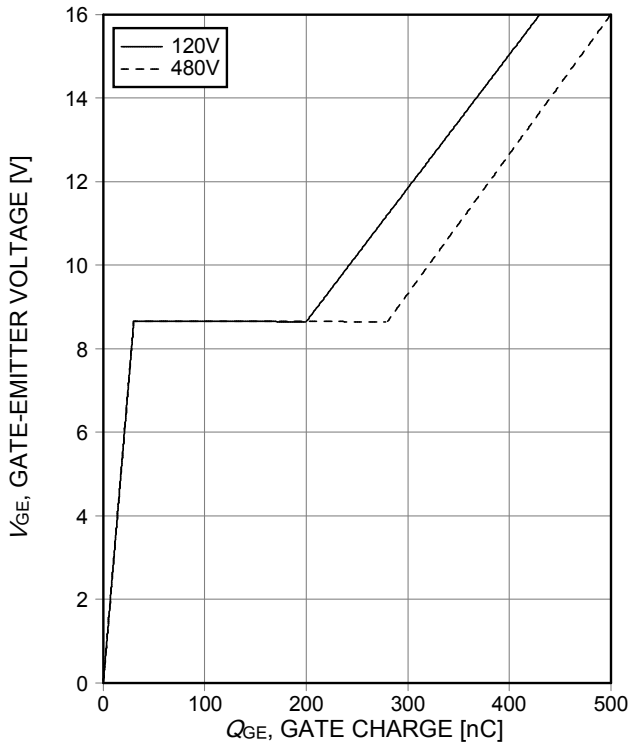
**Figure 14. Typical switching energy losses as a function of gate resistor**  
 (ind. load,  $T_j=175^\circ\text{C}$ ,  $V_{CE}=400\text{V}$ ,  $V_{GE}=15/0\text{V}$ ,  $I_C=75\text{A}$ , test circuit in Fig. E)



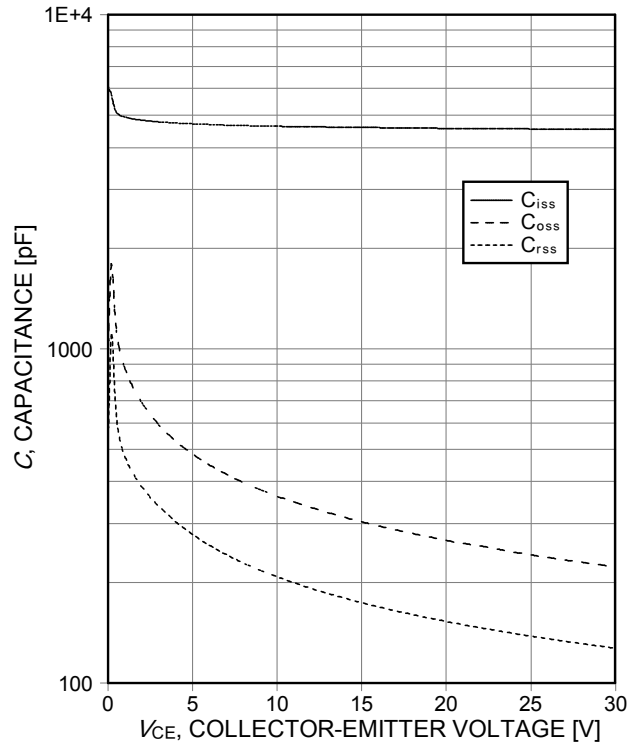
**Figure 15. Typical switching energy losses as a function of junction temperature**  
 (ind. load,  $V_{CE}=400\text{V}$ ,  $V_{GE}=15/0\text{V}$ ,  $I_C=75\text{A}$ ,  $R_G=5,2\Omega$ , test circuit in Fig. E)



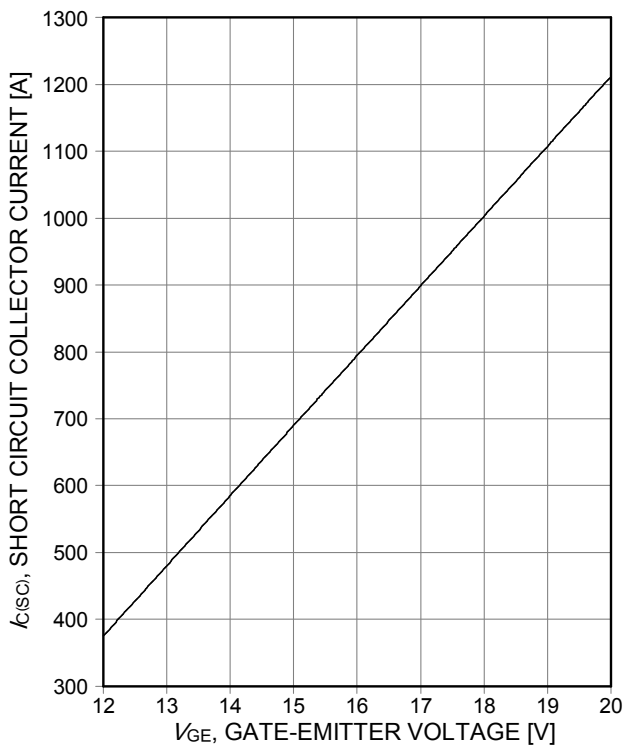
**Figure 16. Typical switching energy losses as a function of collector emitter voltage**  
 (ind. load,  $T_j=175^\circ\text{C}$ ,  $V_{GE}=15/0\text{V}$ ,  $I_C=75\text{A}$ ,  $R_G=5,2\Omega$ , test circuit in Fig. E)



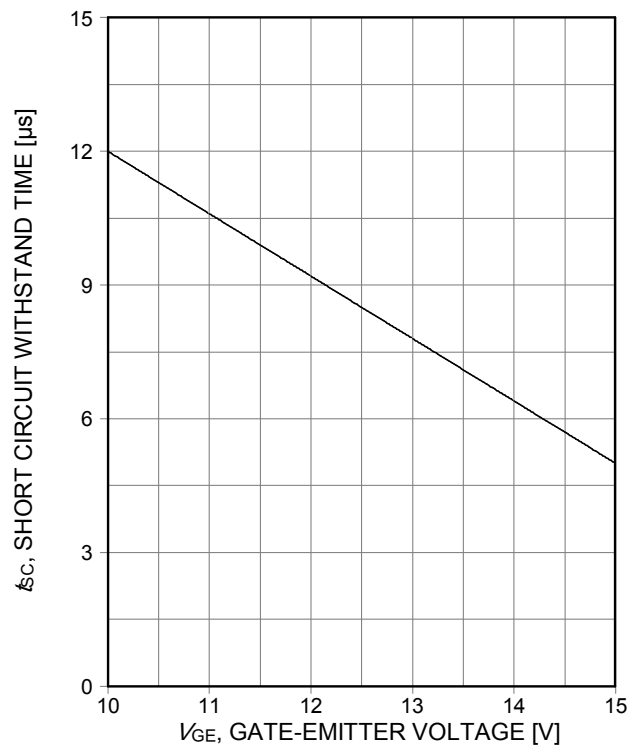
**Figure 17. Typical gate charge**  
( $I_C=75A$ )



**Figure 18. Typical capacitance as a function of collector-emitter voltage**  
( $V_{GE}=0V, f=1MHz$ )



**Figure 19. Typical short circuit collector current as a function of gate-emitter voltage**  
( $V_{CE}\leq 400V, \text{ start at } T_j=25^\circ C$ )



**Figure 20. Short circuit withstand time as a function of gate-emitter voltage**  
( $V_{CE}\leq 400V, \text{ start at } T_j\leq 150^\circ C$ )

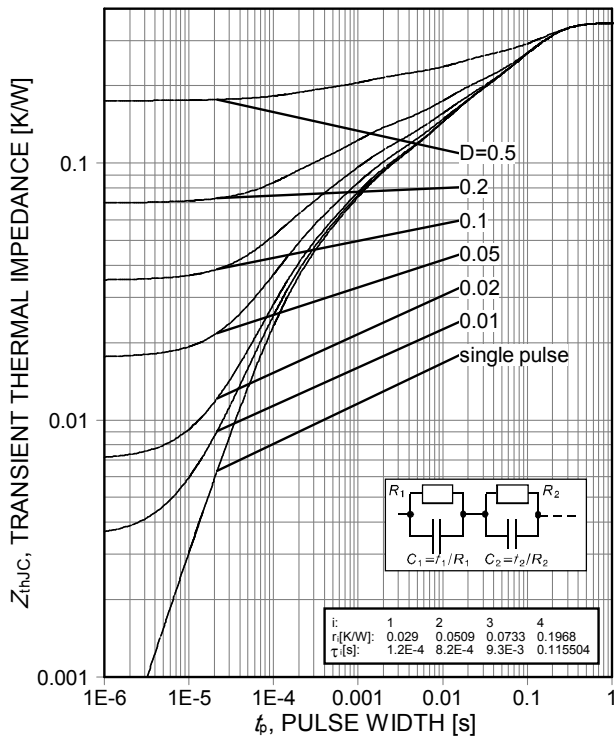
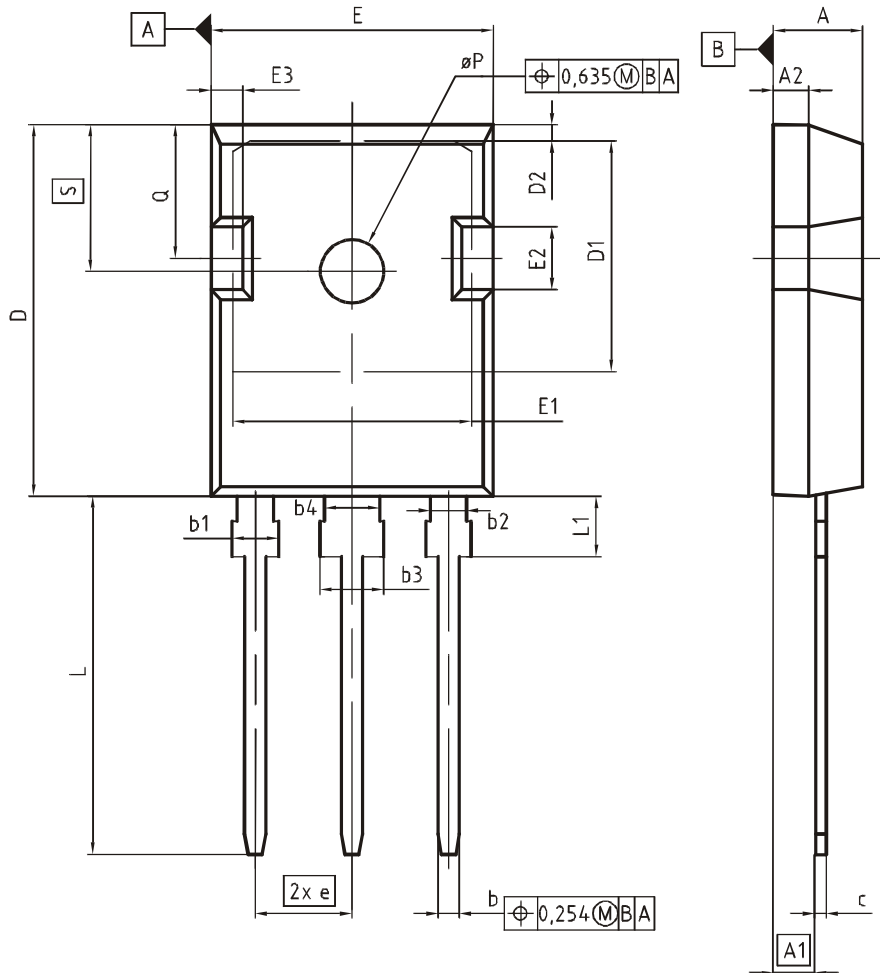


Figure 21. IGBT transient thermal impedance ( $D = t_p/T$ )

PG-TO247-3



| DIM      | MILLIMETERS |       | INCHES      |       |
|----------|-------------|-------|-------------|-------|
|          | MIN         | MAX   | MIN         | MAX   |
| A        | 4.83        | 5.21  | 0.190       | 0.205 |
| A1       | 2.27        | 2.54  | 0.089       | 0.100 |
| A2       | 1.85        | 2.16  | 0.073       | 0.085 |
| b        | 1.07        | 1.33  | 0.042       | 0.052 |
| b1       | 1.90        | 2.41  | 0.075       | 0.095 |
| b2       | 1.90        | 2.16  | 0.075       | 0.085 |
| b3       | 2.87        | 3.38  | 0.113       | 0.133 |
| b4       | 2.87        | 3.13  | 0.113       | 0.123 |
| c        | 0.55        | 0.68  | 0.022       | 0.027 |
| D        | 20.80       | 21.10 | 0.819       | 0.831 |
| D1       | 16.25       | 17.65 | 0.640       | 0.695 |
| D2       | 0.95        | 1.35  | 0.037       | 0.053 |
| E        | 15.70       | 16.13 | 0.618       | 0.635 |
| E1       | 13.10       | 14.15 | 0.516       | 0.557 |
| E2       | 3.68        | 5.10  | 0.145       | 0.201 |
| E3       | 1.00        | 2.60  | 0.039       | 0.102 |
| e        | 5.44 (BSC)  |       | 0.214 (BSC) |       |
| N        | 3           |       | 3           |       |
| L        | 19.80       | 20.32 | 0.780       | 0.800 |
| L1       | 4.10        | 4.47  | 0.161       | 0.176 |
| $\phi P$ | 3.50        | 3.70  | 0.138       | 0.146 |
| Q        | 5.49        | 6.00  | 0.216       | 0.236 |
| S        | 6.04        | 6.30  | 0.238       | 0.248 |

DOCUMENT NO.  
Z8B00003327

SCALE

EUROPEAN PROJECTION

ISSUE DATE  
09-07-2010

REVISION  
05

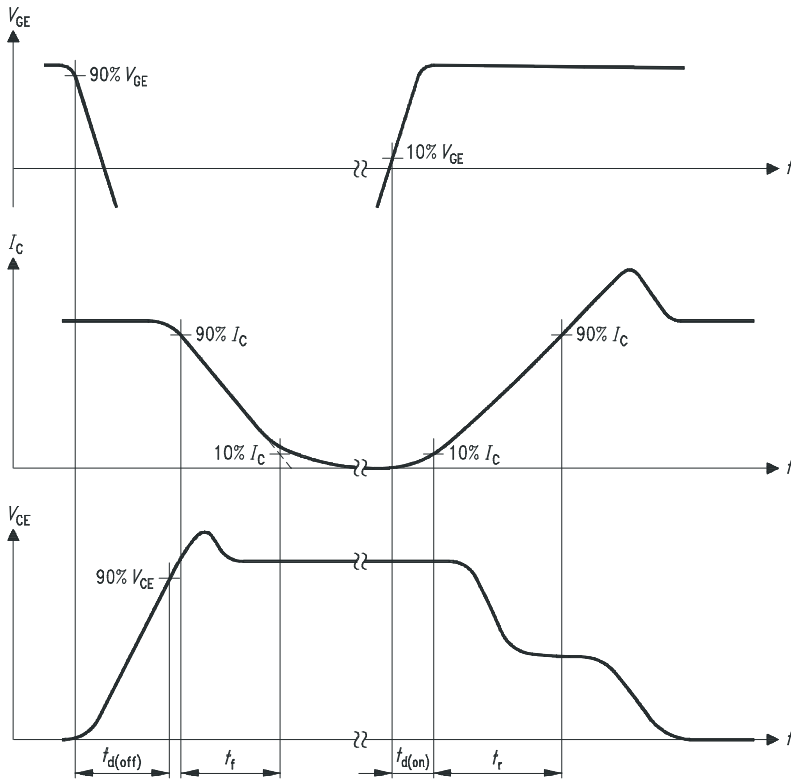


Figure A. Definition of switching times

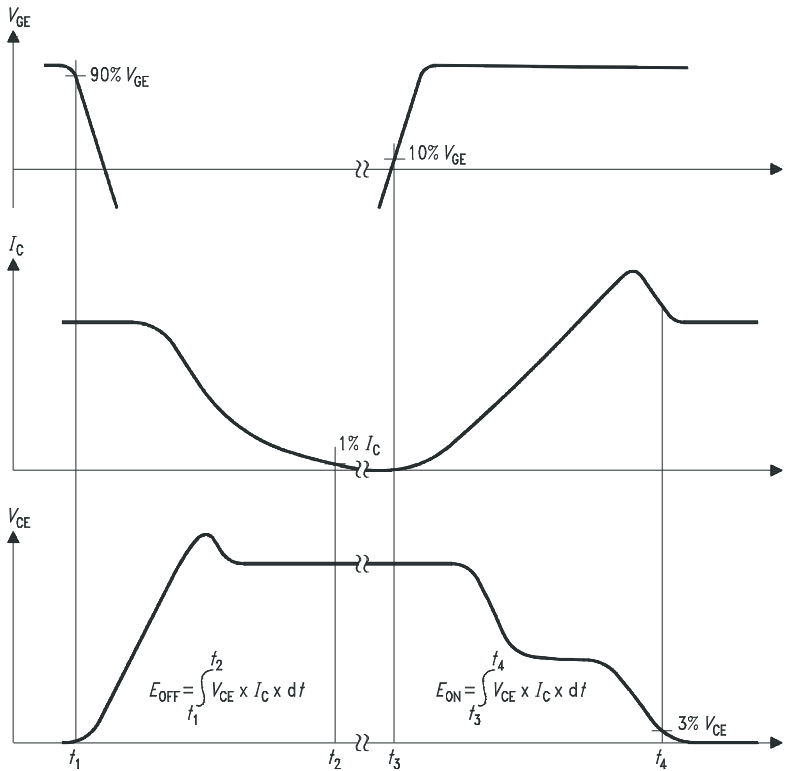


Figure B. Definition of switching losses

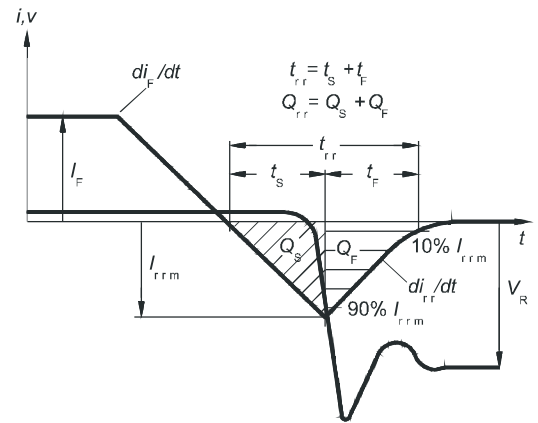


Figure C. Definition of diodes switching characteristics

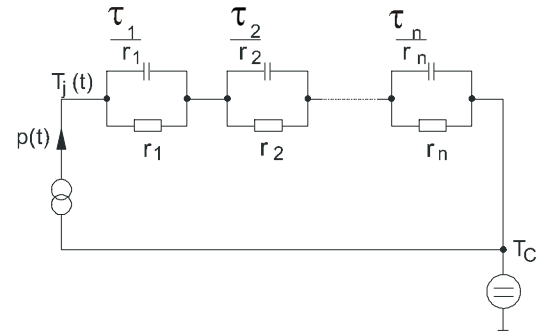


Figure D. Thermal equivalent circuit

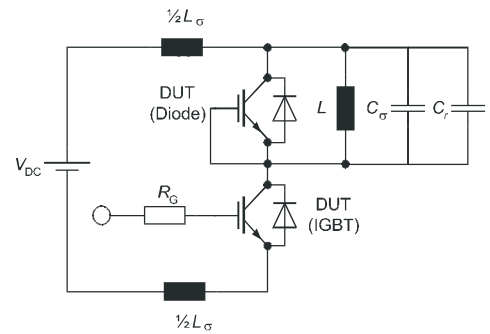


Figure E. Dynamic test circuit  
Parasitic inductance  $L_\sigma$ ,  
Parasitic capacitor  $C_\sigma$ ,  
Relief capacitor  $C_r$   
(only for ZVT switching)