

### Short circuit rugged 1200 V TRENCHSTOP™ IGBT 7 technology copacked with soft, fast recovery Emitter Controlled 7 diode

#### Features

- $V_{CE} = 1200\text{ V}$
- $I_C = 40\text{ A}$
- IGBT co-packed with full current, soft and low  $Q_{rr}$  diode
- Low saturation voltage  $V_{CEsat} = 2.0\text{ V}$  at  $T_{vj} = 175^\circ\text{C}$
- Optimized for hard switching topologies (2-L inverter, 3-L NPC T-type, ...)
- Short circuit ruggedness  $8\ \mu\text{s}$
- Wide range of  $dv/dt$  controllability
- Complete product spectrum and PSpice Models: <http://www.infineon.com/igbt/>

#### Potential applications

- Industrial drives
- Industrial power supplies
- Solar inverters

#### Product validation

- Qualified for industrial applications according to the relevant tests of JEDEC47/20/22

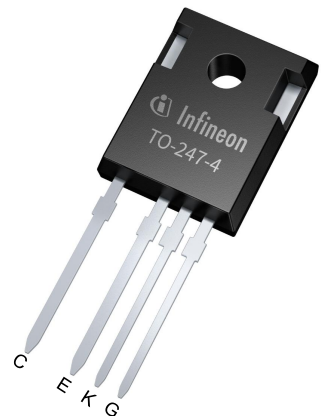

- Halogen-free
- Lead-free
- Green
- RoHS

#### Description

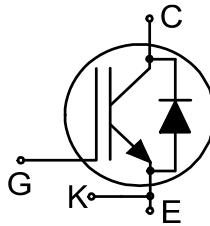

Type	Package	Marking
IKZA40N120CS7	PG-TO247-4-STD-NT3.7	K40MCS7

## Table of contents

	<b>Description</b> .....	1
	<b>Features</b> .....	1
	<b>Potential applications</b> .....	1
	<b>Product validation</b> .....	1
	<b>Table of contents</b> .....	2
<b>1</b>	<b>Package</b> .....	3
<b>2</b>	<b>IGBT</b> .....	3
<b>3</b>	<b>Diode</b> .....	5
<b>4</b>	<b>Characteristics diagrams</b> .....	7
<b>5</b>	<b>Package outlines</b> .....	14
<b>6</b>	<b>Testing conditions</b> .....	15
	<b>Revision history</b> .....	16
	<b>Disclaimer</b> .....	17

## 1 Package

**Table 1** Characteristic values

Parameter	Symbol	Note or test condition	Values			Unit
			Min.	Typ.	Max.	
Internal emitter inductance measured 5 mm (0.197 in.) from case	$L_E$			13		nH
Storage temperature	$T_{stg}$		-55		150	°C
Soldering temperature	$T_{sold}$	wave soldering 1.6 mm (0.063 in.) from case for 10 s			260	°C
Mounting torque	$M$	M3 screw, Maximum of mounting process: 3			0.6	Nm
Thermal resistance, junction-ambient	$R_{th(j-a)}$				40	K/W
IGBT thermal resistance, junction-case	$R_{th(j-c)}$			0.3	0.42	K/W
Diode thermal resistance, junction-case	$R_{th(j-c)}$			0.55	0.75	K/W

## 2 IGBT

**Table 2** Maximum rated values

Parameter	Symbol	Note or test condition	Values	Unit
Collector-emitter voltage	$V_{CE}$	$T_{vj} \geq 25\text{ °C}$	1200	V
DC collector current, limited by $T_{vjmax}$	$I_C$	$T_c = 25\text{ °C}$	82	A
		$T_c = 100\text{ °C}$	56	
Pulsed collector current, $t_p$ limited by $T_{vjmax}$	$I_{Cpulse}$		120	A
Turn-off safe operating area		$V_{CE} \leq 1200\text{ V}, T_{vj} \leq 175\text{ °C}$	120	A
Gate-emitter voltage	$V_{GE}$		$\pm 20$	V
Transient gate-emitter voltage	$V_{GE}$	$t_p \leq 0.5\text{ }\mu\text{s}, D < 0.001$	$\pm 25$	V
Short-circuit withstand time	$t_{SC}$	$V_{CC} \leq 600\text{ V}, V_{GE} = 15\text{ V}$ , Allowed number of short circuits < 1000, Time between short circuits $\geq 1.0\text{ s}, T_{vj} = 150\text{ °C}$	8	$\mu\text{s}$
Power dissipation	$P_{tot}$	$T_{vj} \leq 175\text{ °C}$	$T_c = 25\text{ °C}$	W
			$T_c = 100\text{ °C}$	

**Table 3 Characteristic values**

Parameter	Symbol	Note or test condition		Values			Unit
				Min.	Typ.	Max.	
Collector-emitter saturation voltage	$V_{CEsat}$	$I_C = 40\text{ A}, V_{GE} = 15\text{ V}$	$T_{vj} = 25\text{ °C}$		1.65	2	V
			$T_{vj} = 175\text{ °C}$		2		
Gate-emitter threshold voltage	$V_{GETh}$	$I_C = 0.78\text{ mA}, V_{CE} = V_{GE}$		5.1	5.7	6.5	V
Zero gate-voltage collector current	$I_{CES}$	$V_{CE} = 1200\text{ V}, V_{GE} = 0\text{ V}$	$T_{vj} = 25\text{ °C}$			40	$\mu\text{A}$
			$T_{vj} = 175\text{ °C}$		3500		
Gate-emitter leakage current	$I_{GES}$	$V_{CE} = 0\text{ V}, V_{GE} = 20\text{ V}$				100	nA
Transconductance	$g_{fs}$	$I_C = 40\text{ A}, V_{CE} = 20\text{ V}, T_{vj} = 175\text{ °C}$			17		S
Short-circuit collector current	$I_{SC}$	$V_{CC} \leq 600\text{ V}, V_{GE} = 15\text{ V}, t_{SC} \leq 8\text{ }\mu\text{s}$ , Allowed number of short circuits < 1000, Time between short circuits $\geq 1.0\text{ s}$ , $T_{vj} = 150\text{ °C}$			240		A
Input capacitance	$C_{ies}$	$V_{CE} = 25\text{ V}, V_{GE} = 0\text{ V}, f = 100\text{ kHz}$			5.5		nF
Output capacitance	$C_{oes}$	$V_{CE} = 25\text{ V}, V_{GE} = 0\text{ V}, f = 100\text{ kHz}$			120		pF
Reverse transfer capacitance	$C_{res}$	$V_{CE} = 25\text{ V}, V_{GE} = 0\text{ V}, f = 100\text{ kHz}$			27		pF
Gate charge	$Q_G$	$I_C = 40\text{ A}, V_{GE} = 15\text{ V}, V_{CC} = 960\text{ V}$			230		nC
Turn-on delay time	$t_{d(on)}$	$V_{CC} = 600\text{ V}, V_{GE} = 0/15\text{ V}, R_{G(on)} = 4\text{ }\Omega, R_{G(off)} = 4\text{ }\Omega$	$T_{vj} = 25\text{ °C}, I_C = 40\text{ A}$		28		ns
			$T_{vj} = 175\text{ °C}, I_C = 40\text{ A}$		29		
Rise time (inductive load)	$t_r$	$V_{CC} = 600\text{ V}, V_{GE} = 0/15\text{ V}, R_{G(on)} = 4\text{ }\Omega, R_{G(off)} = 4\text{ }\Omega$	$T_{vj} = 25\text{ °C}, I_C = 40\text{ A}$		15		ns
			$T_{vj} = 175\text{ °C}, I_C = 40\text{ A}$		19		
Turn-off delay time	$t_{d(off)}$	$V_{CC} = 600\text{ V}, V_{GE} = 0/15\text{ V}, R_{G(on)} = 4\text{ }\Omega, R_{G(off)} = 4\text{ }\Omega$	$T_{vj} = 25\text{ °C}, I_C = 40\text{ A}$		176		ns
			$T_{vj} = 175\text{ °C}, I_C = 40\text{ A}$		258		
Fall time (inductive load)	$t_f$	$V_{CC} = 600\text{ V}, V_{GE} = 0/15\text{ V}, R_{G(on)} = 4\text{ }\Omega, R_{G(off)} = 4\text{ }\Omega$	$T_{vj} = 25\text{ °C}, I_C = 40\text{ A}$		110		ns
			$T_{vj} = 175\text{ °C}, I_C = 40\text{ A}$		260		
Turn-on energy	$E_{on}$	$V_{CC} = 600\text{ V}, V_{GE} = 0/15\text{ V}, R_{G(on)} = 4\text{ }\Omega, R_{G(off)} = 4\text{ }\Omega$	$T_{vj} = 25\text{ °C}, I_C = 40\text{ A}$		1.23		mJ
			$T_{vj} = 175\text{ °C}, I_C = 40\text{ A}$		2.1		

(table continues...)

**Table 3 (continued) Characteristic values**

Parameter	Symbol	Note or test condition	Values			Unit
			Min.	Typ.	Max.	
Turn-off energy	$E_{off}$	$V_{CC} = 600\text{ V}, V_{GE} = 0/15\text{ V},$ $R_{G(on)} = 4\ \Omega, R_{G(off)} = 4\ \Omega$	$T_{vj} = 25\text{ }^\circ\text{C},$ $I_C = 40\text{ A}$	1.78		mJ
Total switching energy	$E_{ts}$	$V_{CC} = 600\text{ V}, V_{GE} = 0/15\text{ V},$ $R_{G(on)} = 4\ \Omega, R_{G(off)} = 4\ \Omega$	$T_{vj} = 25\text{ }^\circ\text{C},$ $I_C = 40\text{ A}$	3.01		mJ
			$T_{vj} = 175\text{ }^\circ\text{C},$ $I_C = 40\text{ A}$	5.8		
Operating junction temperature	$T_{vj}$		-40		175	$^\circ\text{C}$

Note: Electrical Characteristic, at  $T_{vj} = 25^\circ\text{C}$ , unless otherwise specified.

### 3 Diode

**Table 4 Maximum rated values**

Parameter	Symbol	Note or test condition	Values	Unit	
Diode forward current, limited by $T_{vjmax}$	$I_F$		$T_c = 25\text{ }^\circ\text{C}$	69	A
			$T_c = 100\text{ }^\circ\text{C}$	46	
Diode pulsed current, $t_p$ limited by $T_{vjmax}$	$I_{Fpulse}$		120	A	
Power dissipation	$P_{tot}$		$T_c = 25\text{ }^\circ\text{C}$	208	W
			$T_c = 100\text{ }^\circ\text{C}$	104	

**Table 5 Characteristic values**

Parameter	Symbol	Note or test condition	Values			Unit
			Min.	Typ.	Max.	
Diode forward voltage	$V_F$	$I_F = 40\text{ A}$	$T_{vj} = 25\text{ }^\circ\text{C}$	1.65	2.15	V
			$T_{vj} = 175\text{ }^\circ\text{C}$	1.6		
Diode reverse recovery time	$t_{rr}$	$V_R = 600\text{ V}, R_{G(on)} = 4\ \Omega$	$T_{vj} = 25\text{ }^\circ\text{C},$ $I_F = 40\text{ A}$	110		ns
			$T_{vj} = 175\text{ }^\circ\text{C},$ $I_F = 40\text{ A}$	220		
Diode reverse recovery charge	$Q_{rr}$	$V_R = 600\text{ V}, R_{G(on)} = 4\ \Omega$	$T_{vj} = 25\text{ }^\circ\text{C},$ $I_F = 40\text{ A}$	2.5		$\mu\text{C}$
			$T_{vj} = 175\text{ }^\circ\text{C},$ $I_F = 40\text{ A}$	6.3		

(table continues...)

Table 5 (continued) Characteristic values

Parameter	Symbol	Note or test condition	Values			Unit	
			Min.	Typ.	Max.		
Diode peak reverse recovery current	$I_{rrm}$	$V_R = 600 \text{ V}, R_{G(on)} = 4 \text{ } \Omega$	$T_{vj} = 25 \text{ } ^\circ\text{C},$ $I_F = 40 \text{ A}$		63	A	
			$T_{vj} = 175 \text{ } ^\circ\text{C},$ $I_F = 40 \text{ A}$		88		
Diode peak rate of fall of reverse recovery current	$di_{rr}/dt$	$V_R = 600 \text{ V}, R_{G(on)} = 4 \text{ } \Omega$	$T_{vj} = 25 \text{ } ^\circ\text{C},$ $I_F = 40 \text{ A}$		-1020	A/ $\mu\text{s}$	
			$T_{vj} = 175 \text{ } ^\circ\text{C},$ $I_F = 40 \text{ A}$		-1430		
Reverse recovery energy	$E_{rec}$	$V_R = 600 \text{ V}, R_{G(on)} = 4 \text{ } \Omega$	$T_{vj} = 25 \text{ } ^\circ\text{C},$ $I_F = 40 \text{ A}$		0.89	mJ	
			$T_{vj} = 175 \text{ } ^\circ\text{C},$ $I_F = 40 \text{ A}$		2.54		
Operating junction temperature	$T_{vj}$			-40		175	$^\circ\text{C}$

Note: For optimum lifetime and reliability, Infineon recommends operating conditions that do not exceed 80% of the maximum ratings stated in this datasheet.

Dynamic test circuit, parasitic inductance  $L_\sigma = 30 \text{ nH}$ ,  $C_\sigma = 18 \text{ pF}$ .

## 4 Characteristics diagrams

### Reverse bias safe operating area

$$I_C = f(V_{CE})$$

$$T_{vj} \leq 175^\circ\text{C}, V_{CE} \leq 1200\text{ V}$$

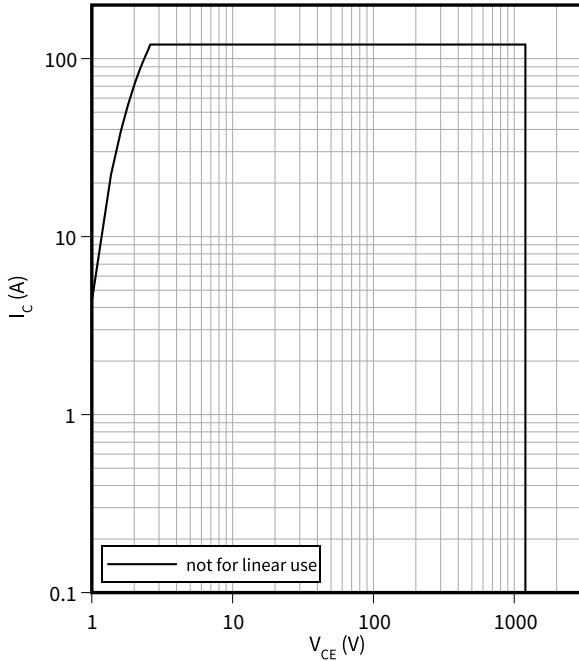

### Typical output characteristic

$$I_C = f(V_{CE})$$

$$T_{vj} = 25^\circ\text{C}$$

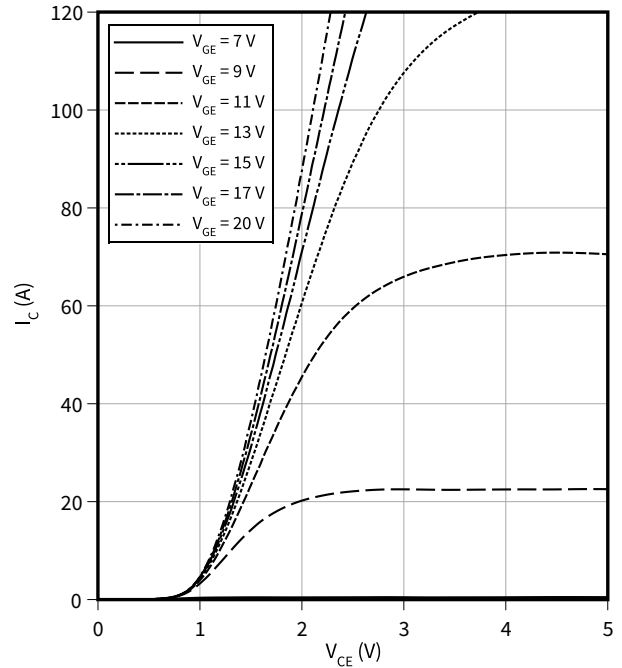

### Typical output characteristic

$$I_C = f(V_{CE})$$

$$T_{vj} = 175^\circ\text{C}$$

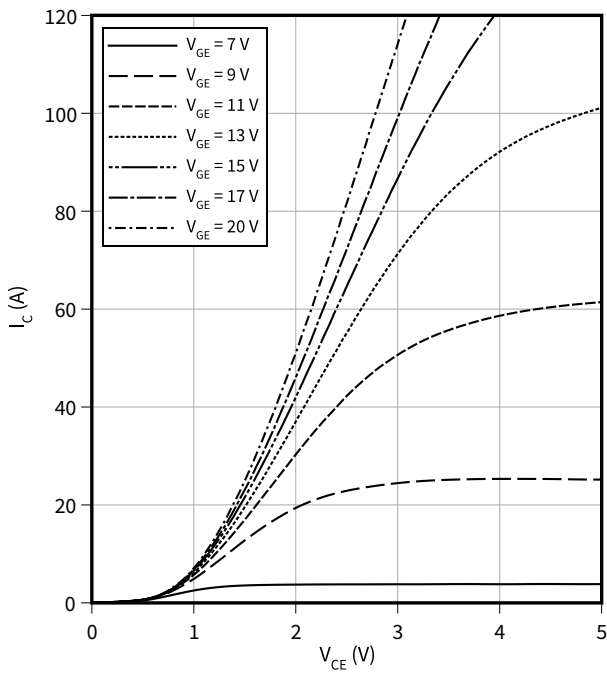

### Typical transfer characteristic

$$I_C = f(V_{GE})$$

$$V_{CE} = 20\text{ V}$$

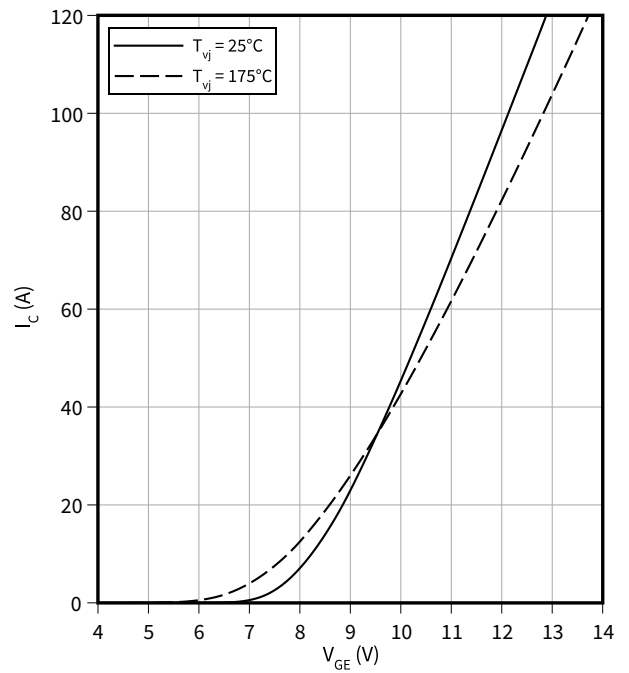

4 Characteristics diagrams

**Typical collector-emitter saturation voltage as a function of junction temperature**

$V_{CEsat} = f(T_{vj})$

$V_{GE} = 15 \text{ V}$

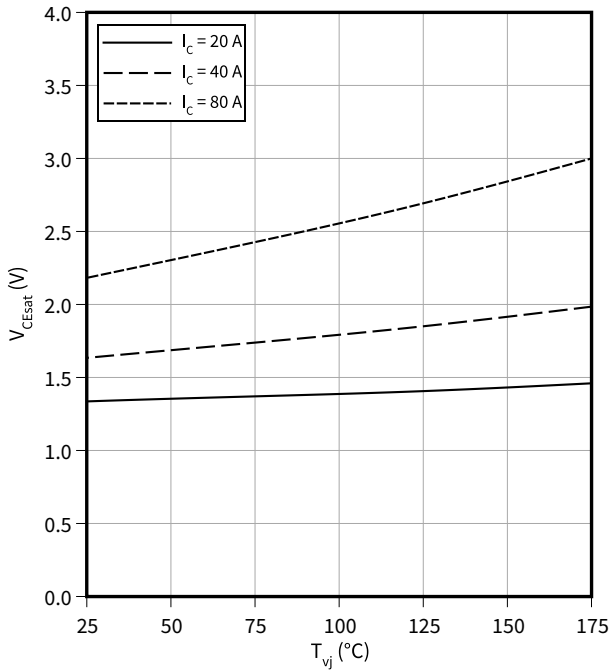

**Gate-emitter threshold voltage as a function of junction temperature**

$V_{GEth} = f(T_{vj})$

$I_C = 0.78 \text{ mA}$

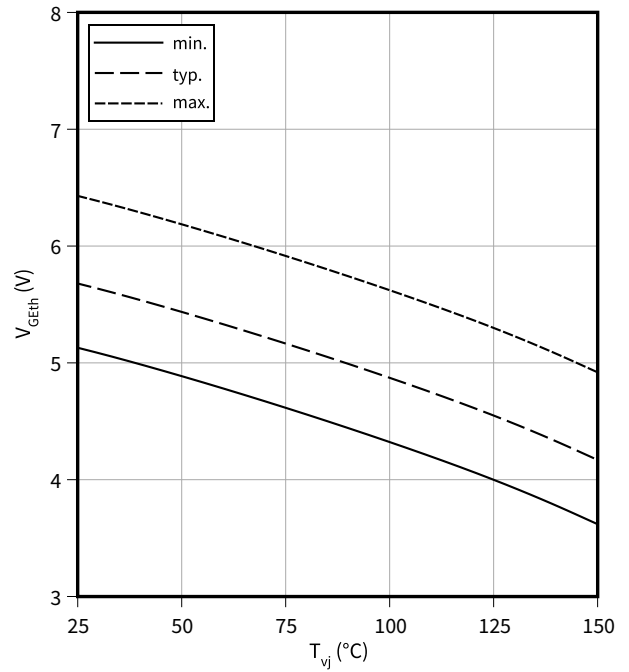

**Typical switching times as a function of collector current**

$t = f(I_C)$

$V_{CC} = 600 \text{ V}, T_{vj} = 175 \text{ °C}, V_{GE} = 0/15 \text{ V}, R_G = 4 \text{ } \Omega$

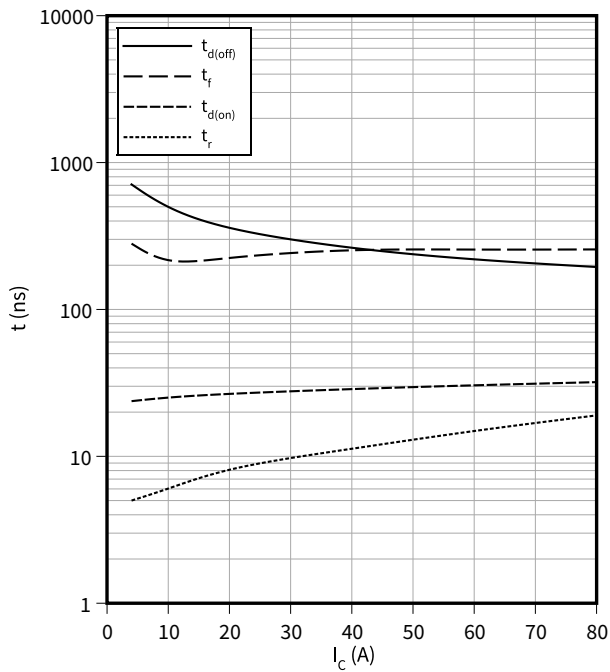

**Typical switching times as a function of gate resistor**

$t = f(R_G)$

$I_C = 40 \text{ A}, V_{CC} = 600 \text{ V}, T_{vj} = 175 \text{ °C}, V_{GE} = 0/15 \text{ V}$

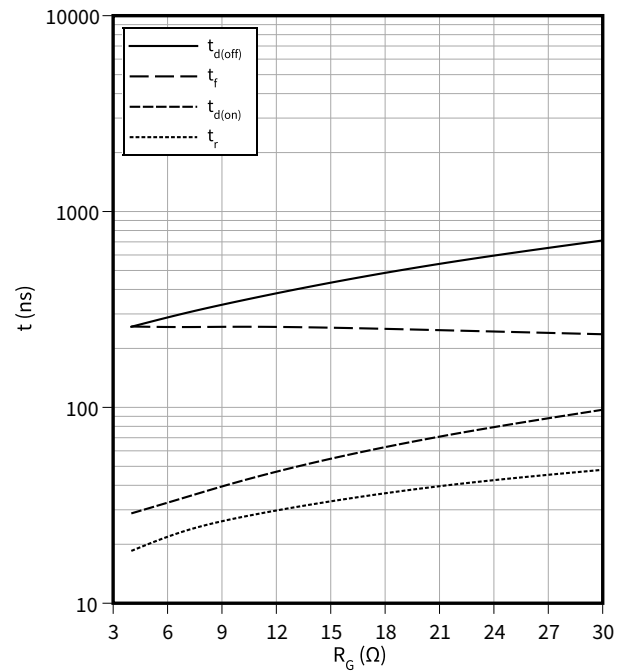



4 Characteristics diagrams

**Typical switching times as a function of junction temperature**

$t = f(T_{vj})$

$I_C = 40\text{ A}, V_{CC} = 600\text{ V}, V_{GE} = 0/15\text{ V}, R_G = 4\ \Omega$

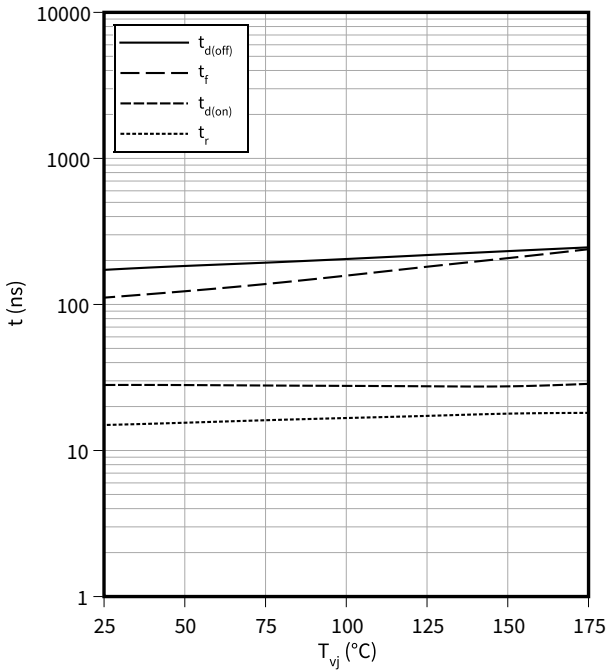

**Typical switching energy losses as a function of collector current**

$E = f(I_C)$

$V_{CC} = 600\text{ V}, T_{vj} = 175\text{ }^\circ\text{C}, V_{GE} = 0/15\text{ V}, R_G = 4\ \Omega$

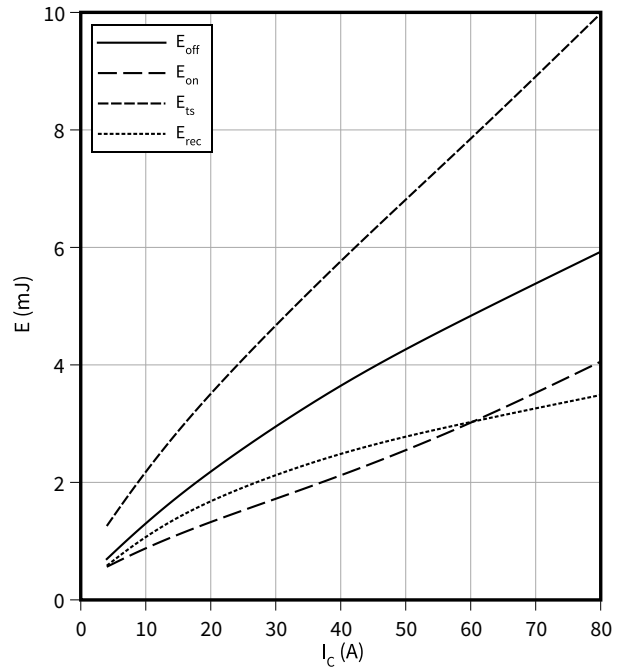

**Typical switching energy losses as a function of gate resistor**

$E = f(R_G)$

$I_C = 40\text{ A}, V_{CC} = 600\text{ V}, T_{vj} = 175\text{ }^\circ\text{C}, V_{GE} = 0/15\text{ V}$

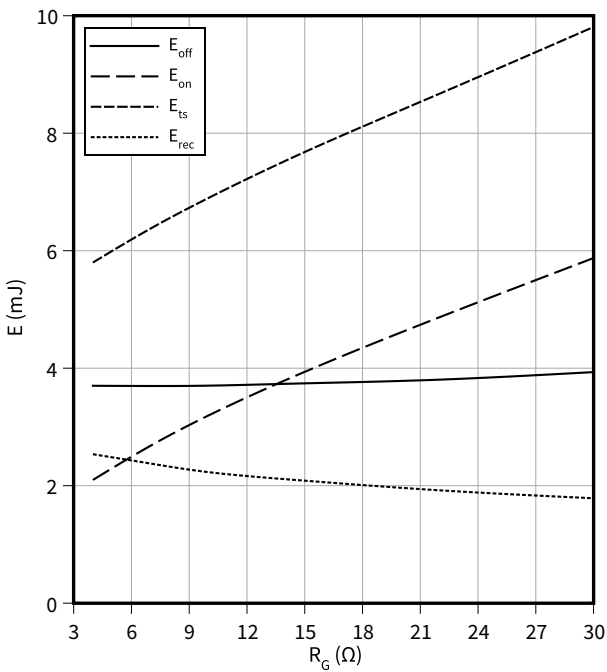

**Typical switching energy losses as a function of junction temperature**

$E = f(T_{vj})$

$I_C = 40\text{ A}, V_{CC} = 600\text{ V}, V_{GE} = 0/15\text{ V}, R_G = 4\ \Omega$

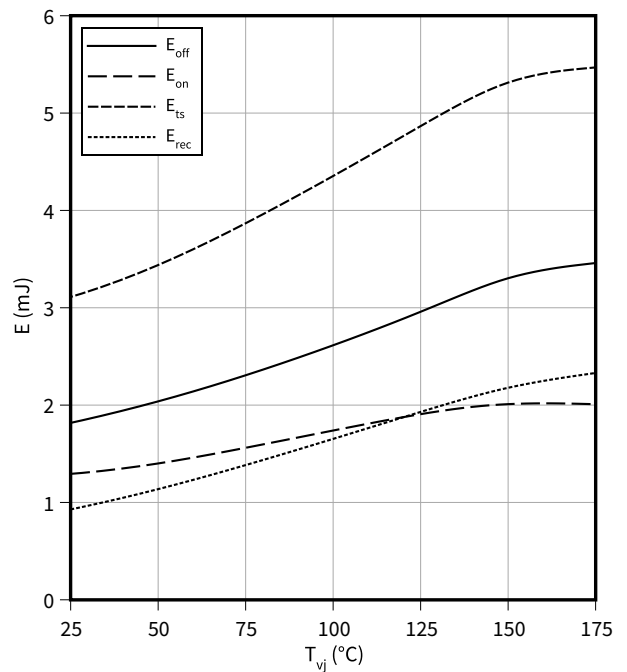

4 Characteristics diagrams

**Typical switching energy losses as a function of collector emitter voltage**

$E = f(V_{CE})$

$I_C = 40 \text{ A}, V_{GE} = 0/15 \text{ V}, T_{vj} = 175 \text{ }^\circ\text{C}, R_G = 4 \text{ } \Omega$

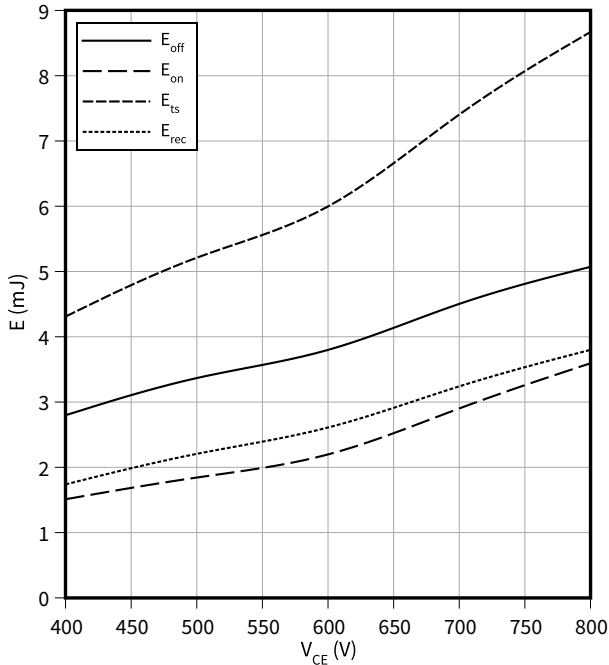

**Typical gate charge**

$V_{GE} = f(Q_G)$

$I_C = 40 \text{ A}$

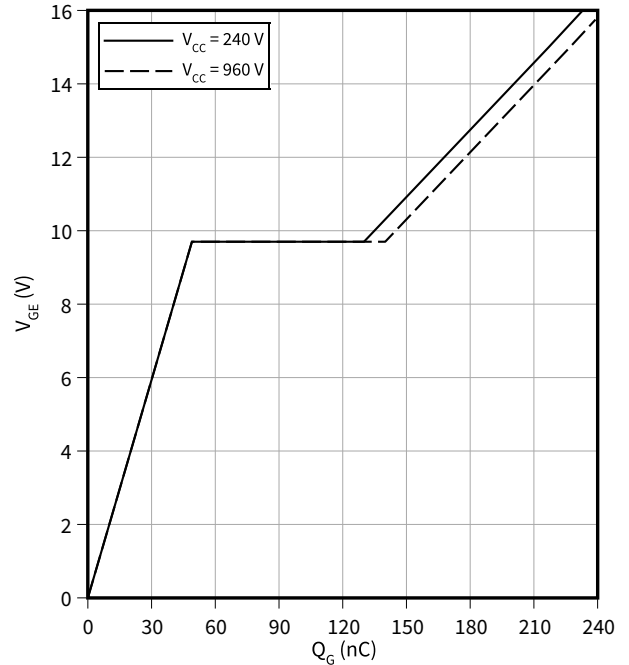

**Typical capacitance as a function of collector-emitter voltage**

$C = f(V_{CE})$

$f = 100 \text{ kHz}, V_{GE} = 0 \text{ V}$

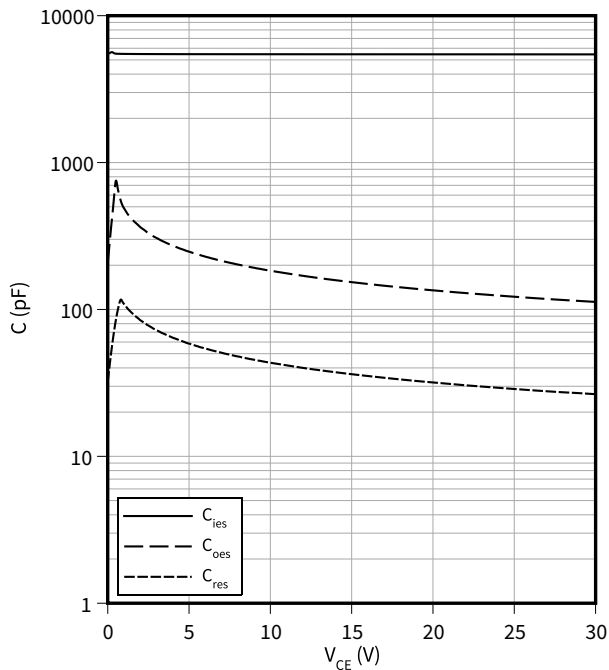

**Typical short circuit collector current as a function of gate-emitter voltage**

$I_{C(SC)} = f(V_{GE})$

$T_{vj} = 150 \text{ }^\circ\text{C}, V_{CC} \leq 600 \text{ V}$

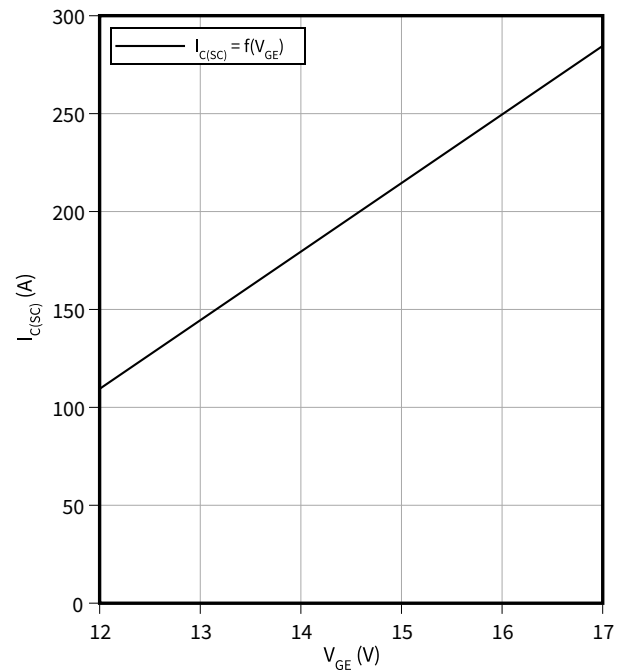

4 Characteristics diagrams

**Short circuit withstand time as a function of gate-emitter voltage**

$$t_{SC} = f(V_{GE})$$

$T_{vj} \leq 150\text{ °C}, V_{CC} \leq 600\text{ V}$

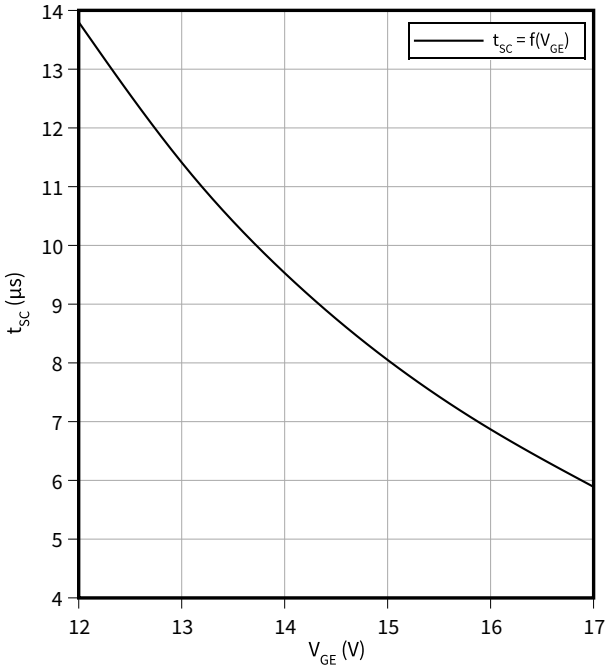

**IGBT transient thermal impedance as a function of pulse width**

$$Z_{th(j-c)} = f(t_p)$$

$$D = t_p/T$$

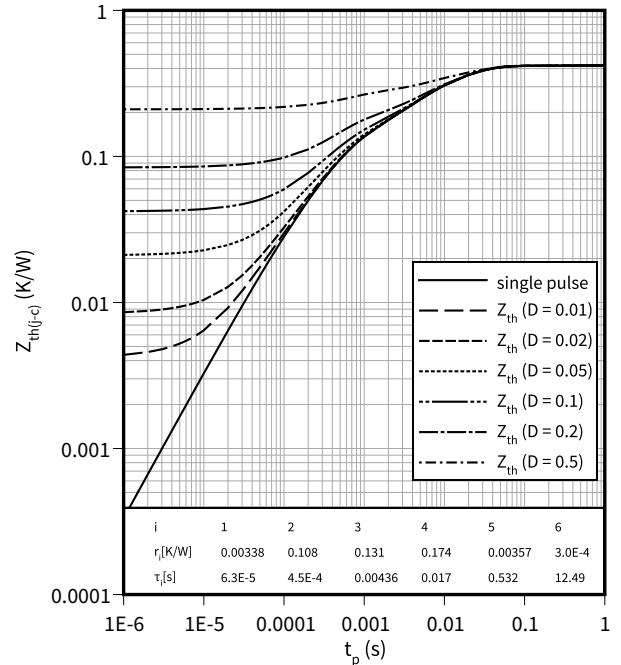

**Diode transient thermal impedance as a function of pulse width**

$$Z_{th(j-c)} = f(t_p)$$

$$D = t_p/T$$

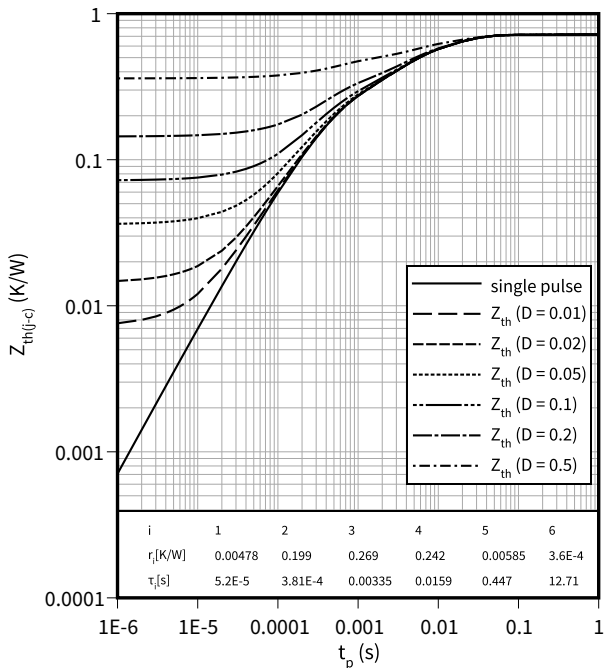

**Typical diode forward current as a function of forward voltage**

$$I_F = f(V_F)$$

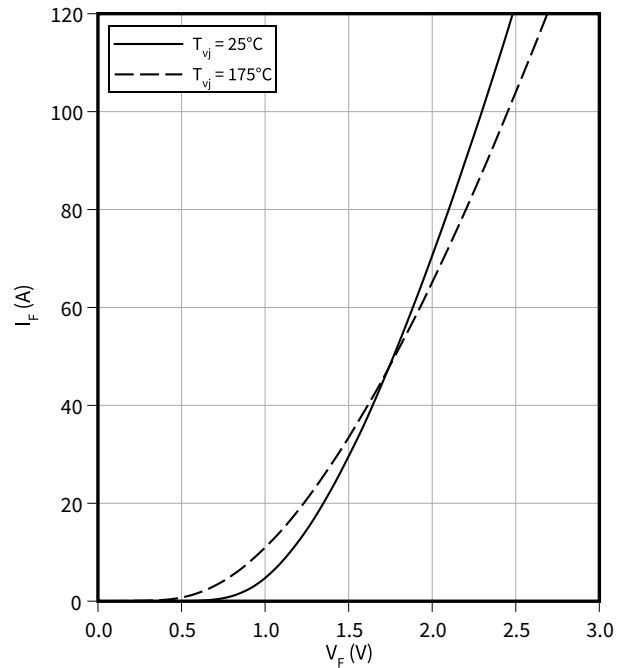

4 Characteristics diagrams

**Typical diode forward voltage as a function of junction temperature**

$V_F = f(T_{vj})$

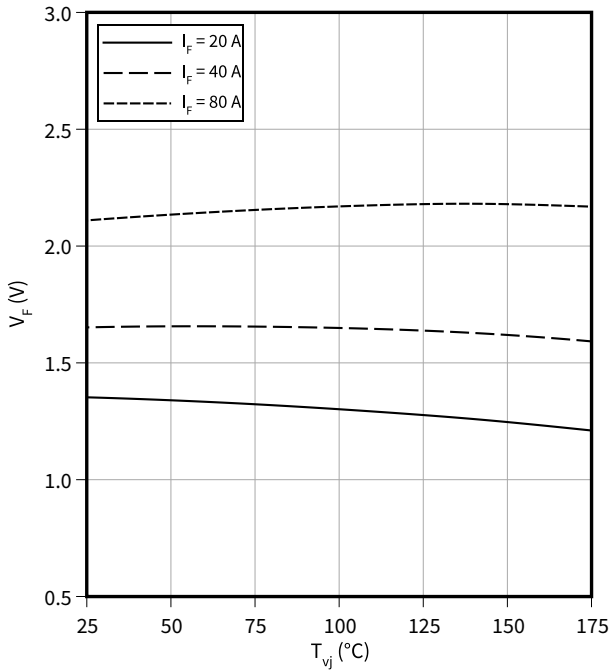

**Typical diode current slope as a function of gate resistor**

$di_F/dt = f(R_G)$

$V_R = 600$  V,  $I_F = 40$  A

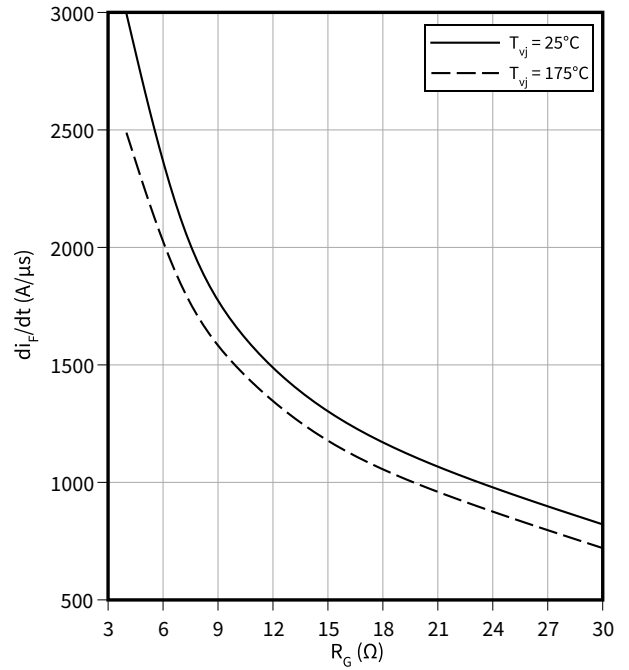

**Typical reverse recovery time as a function of diode current slope**

$t_{rr} = f(di_F/dt)$

$V_R = 600$  V,  $I_F = 40$  A

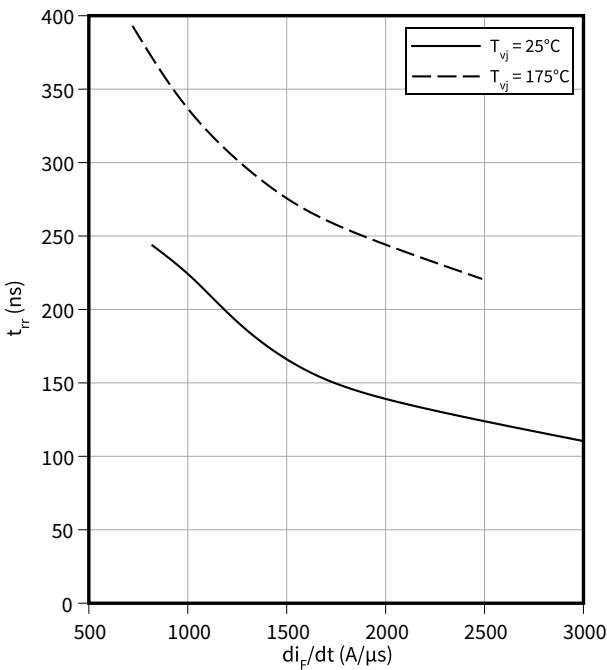

**Typical reverse recovery charge as a function of diode current slope**

$Q_{rr} = f(di_F/dt)$

$V_R = 600$  V,  $I_F = 40$  A

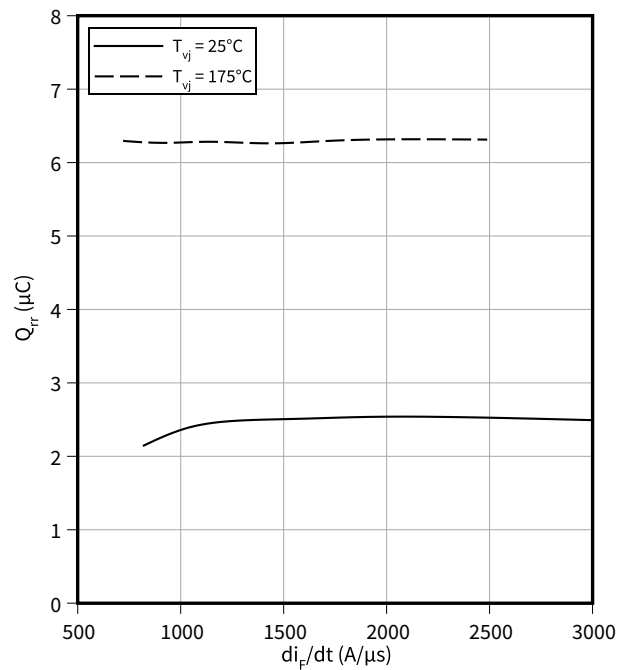

4 Characteristics diagrams

**Typical reverse recovery current as a function of diode current slope**

$$I_{rrm} = f(di_F/dt)$$

$V_R = 600\text{ V}, I_F = 40\text{ A}$

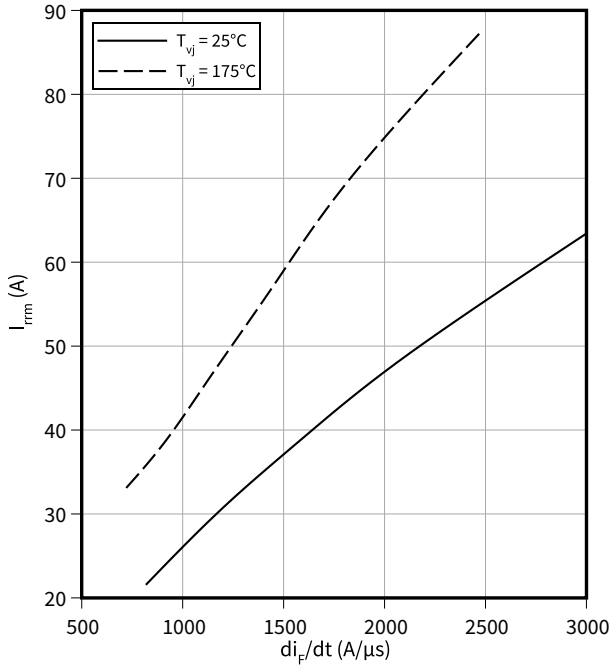

**Typical diode peak rate of fall of reverse recovery current as a function of diode current slope**

$$di_{rr}/dt = f(di_F/dt)$$

$V_R = 600\text{ V}, I_F = 40\text{ A}$

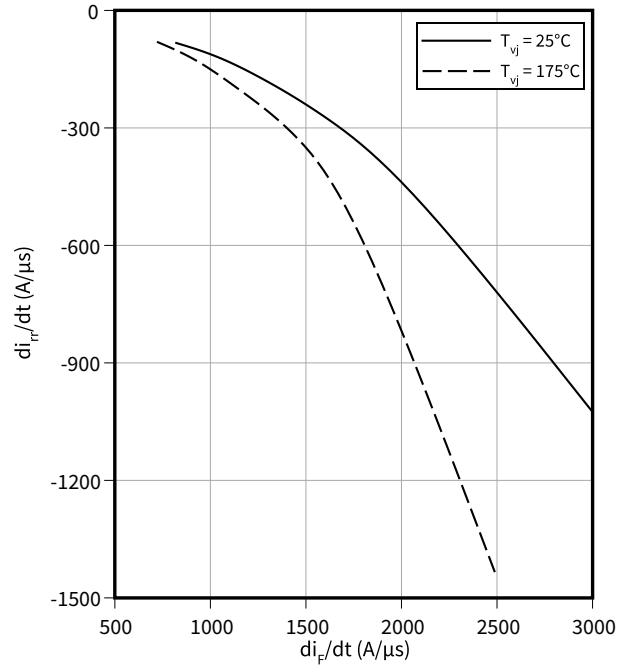

**Typical reverse energy losses as a function of diode current slope**

$$E_{rec} = f(di_F/dt)$$

$V_R = 600\text{ V}, I_F = 40\text{ A}$

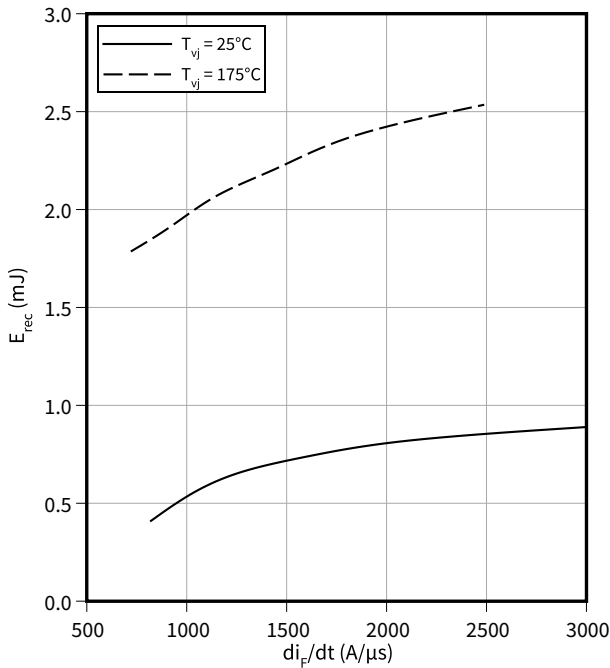

5 Package outlines

PG-TO247-4-STD-NT3.7

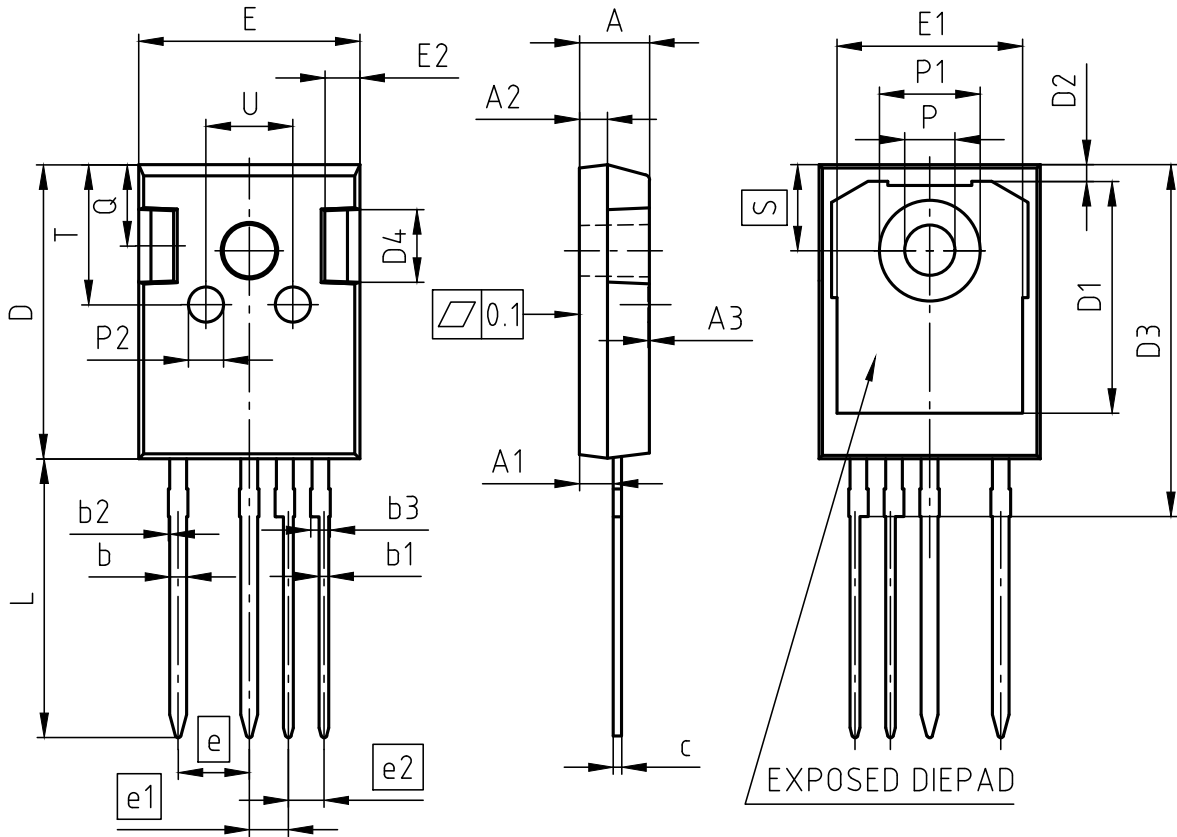

NOTES:  
ALL DIMENSIONS DO NOT INCLUDE MOLD FLASH OR PROTRUSIONS.

PACKAGE - GROUP NUMBER:		PG-TO247-4-U02			
DIMENSIONS	MILLIMETERS		DIMENSIONS	MILLIMETERS	
	MIN.	MAX.		MIN.	MAX.
A	4.90	5.10	E	15.70	15.90
A1	2.31	2.51	E1	13.10	13.50
A2	1.90	2.10	E2	2.40	2.60
A3	0.05	0.25	e	5.08	
b	1.10	1.30	e1	2.79	
b1	0.65	0.79	e2	2.54	
b2	---	0.20	N	4	
b3	1.34	1.44	L	19.80	20.10
c	0.58	0.66	øP	3.50	3.70
D	20.90	21.10	øP1	7.00	7.40
D1	16.25	16.85	øP2	2.40	2.60
D2	1.05	1.35	Q	5.60	6.00
D3	24.97	25.27	S	6.15	
D4	4.90	5.10	T	9.80	10.20
			U	6.00	6.40

Figure 1

6 Testing conditions

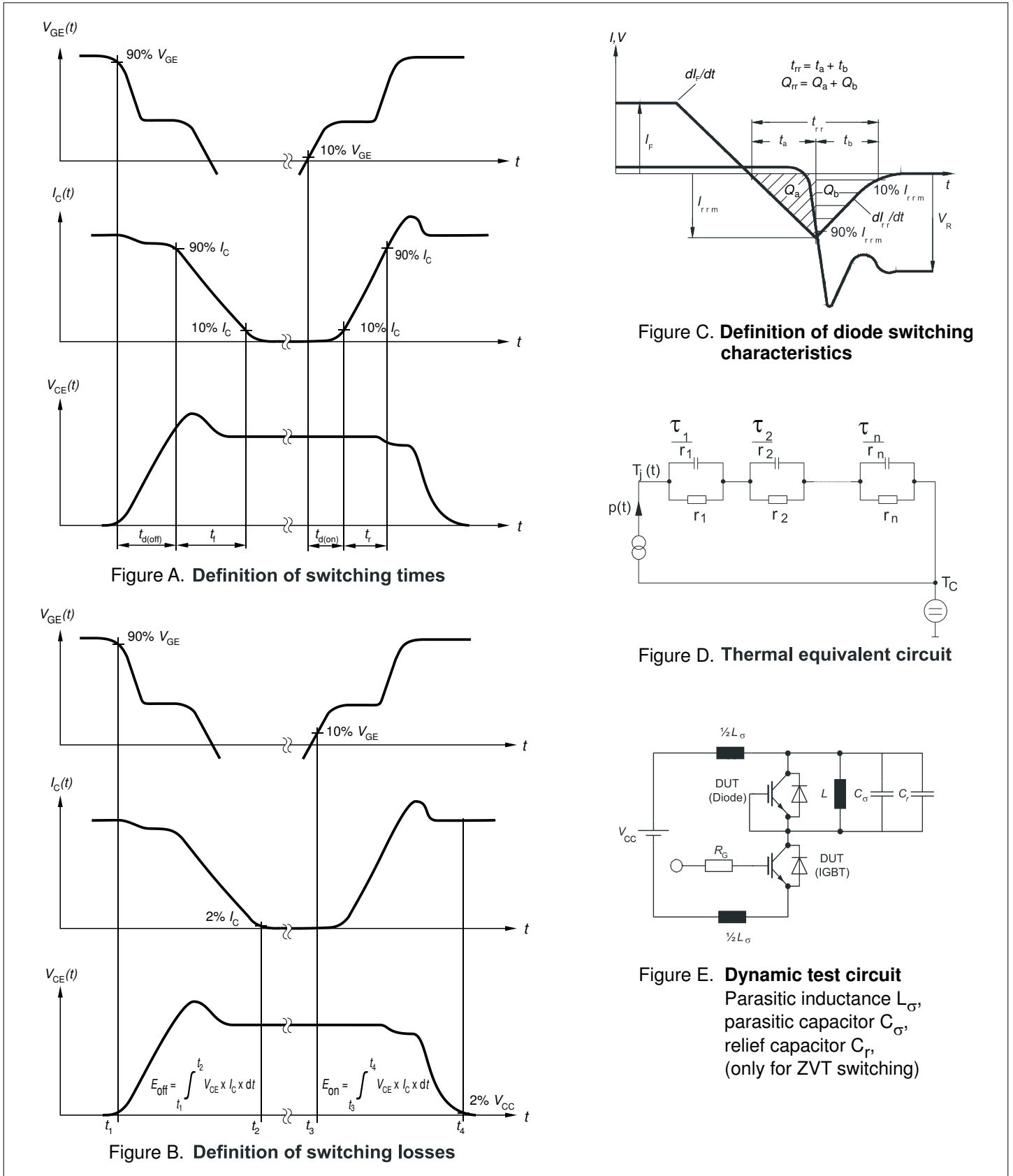

Figure 2

**Revision history**

<b>Document revision</b>	<b>Date of release</b>	<b>Description of changes</b>
0.10	2022-05-04	Target datasheet
1.00	2022-12-05	Final datasheet
1.10	2023-01-23	Correction of boundary condition of diagrams $I_{C(SC)} = f(V_{GE})$ and $t_{SC} = f(V_{GE})$