

IM70A135V01

[Technical documents](#)
[Kits and boards](#)
[Support](#)

High performance analog XENSIV™ MEMS microphone

Features

- Ultra-low 170µA current consumption in high performance mode
- Low current consumption 70µA in low power mode
- Signal-to-noise ratio of 70dB(A) SNR
- Acoustic overload point at 135dB SPL
- Flat frequency response with a low-frequency roll-off at 37 Hz
- Package dimensions: 3.50mm x 2.65mm x 1.00mm

 RoHS

 Green

 Halogen-free

Potential applications

- Active Noise Cancellation (ANC) headphones and wireless earbuds (TWS)
- Devices with Voice User Interface (VUI)
 - Smart speakers
 - Home automation
 - IoT devices
- High quality audio capturing
 - Conference systems
 - Cameras and camcorders
- Industrial or home monitoring with audio pattern detection

Product validation

Technology qualified for industrial applications.

Ready for validation in industrial applications according to the relevant tests of IEC 60747 and 60749 or alternatively JEDEC47/20/22.

Description

Infineon's XENSIV™ MEMS analog differential microphone IM70A135V01 is a compact size and high-performance microphone with a very high acoustic overload point of 135 dB SPL. This microphone is based on Infineon's new Sealed Dual Membrane MEMS technology which delivers high ingress protection (IP57) at a microphone level. The small size makes this microphone especially suited for TWS earbud applications.

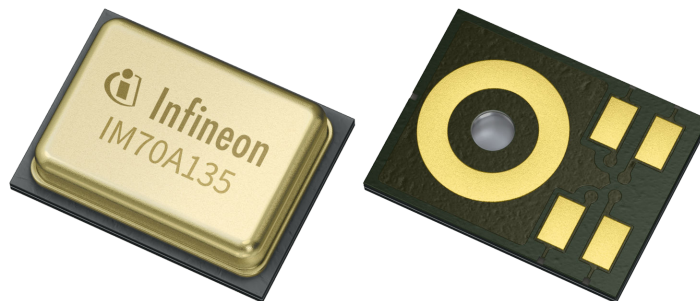

Type	Package	Marking
IM70A135V01	PG-TLGA-5-5	I70A13

Table of contents

	Features	1
	Potential applications	1
	Product validation	1
	Description	1
	Table of contents	2
1	Block diagram	3
2	Typical microphone interface	3
3	Typical performance characteristics	4
4	Acoustic characteristics	6
4.1	Free field frequency response	7
5	Electrical characteristics and parameters	8
5.1	Absolute maximum ratings	8
5.2	Electrical characteristics	8
5.3	Electrical parameters	9
6	Package information	10
7	Footprint and stencil recommendation	11
8	Packing information	12
9	Reflow soldering and board assembly	13
10	Reliability specifications	15
10.1	Environmental robustness	16
	Revision history	17
	Disclaimer	18

1 Block diagram

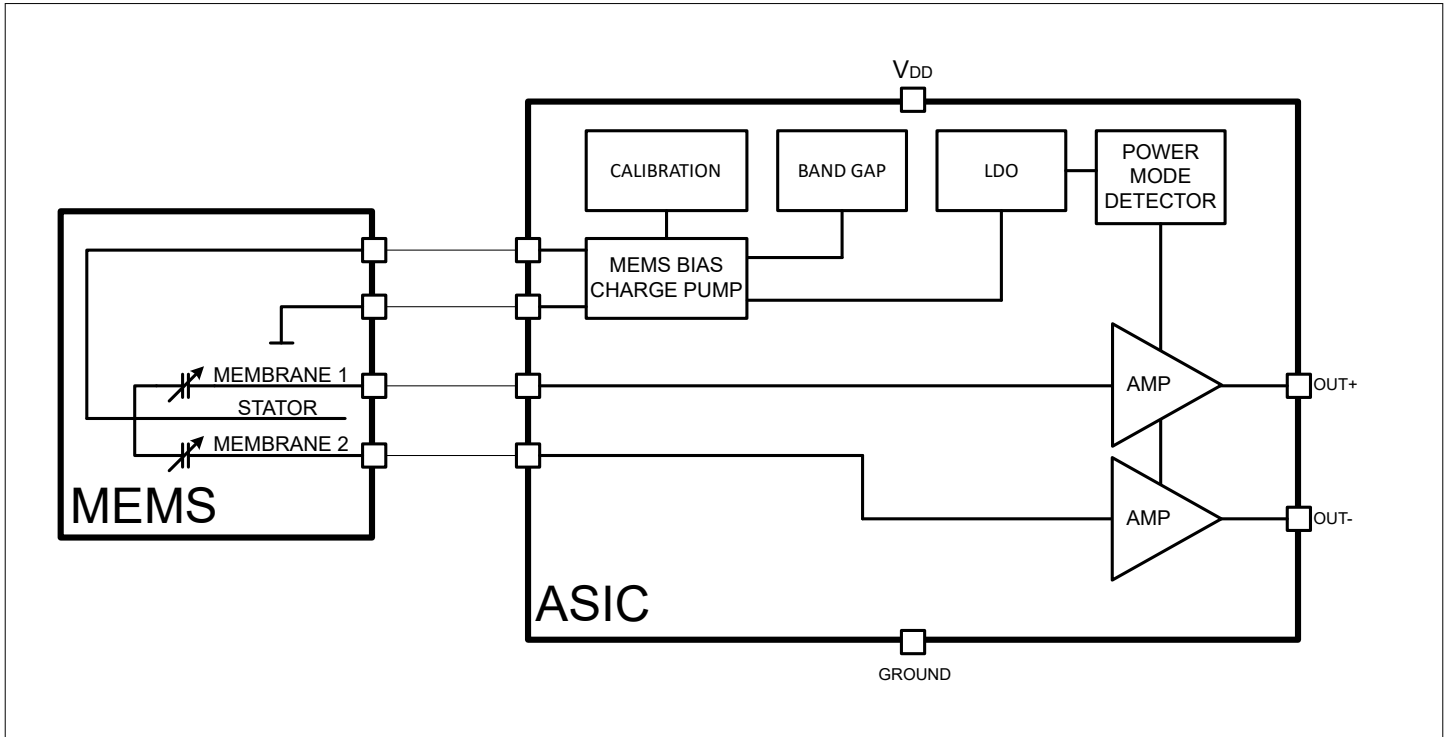

Figure 1 IM70A135V01 block diagram

2 Typical microphone interface

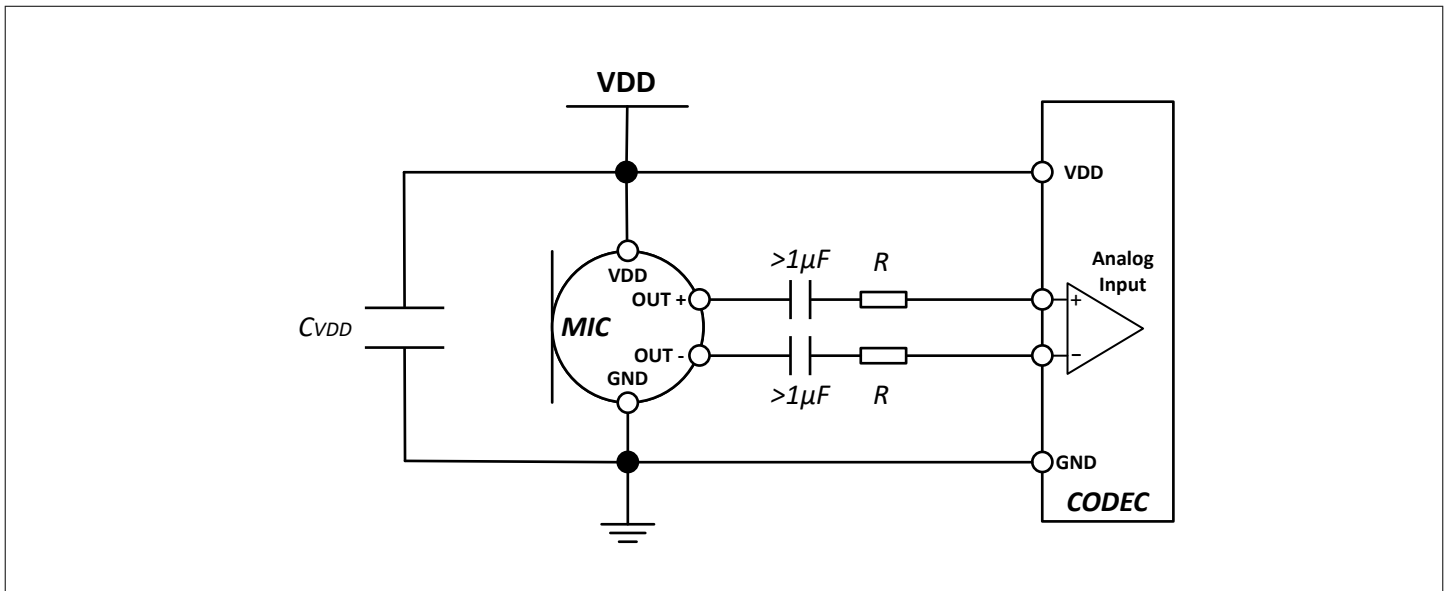

Figure 2 Differential analog microphone interface example

Note: Power supply filtering capacitors should be placed physically as close to the microphone as possible. Detailed information on electrical, acoustical, and mechanical implementation can be found in the application note on XENSIV™ MEMS microphone [web page](#)

3 Typical performance characteristics

Test conditions (unless otherwise specified): $V_{DD} = 2.75V$, $T_A = 25^\circ C$, output unloaded

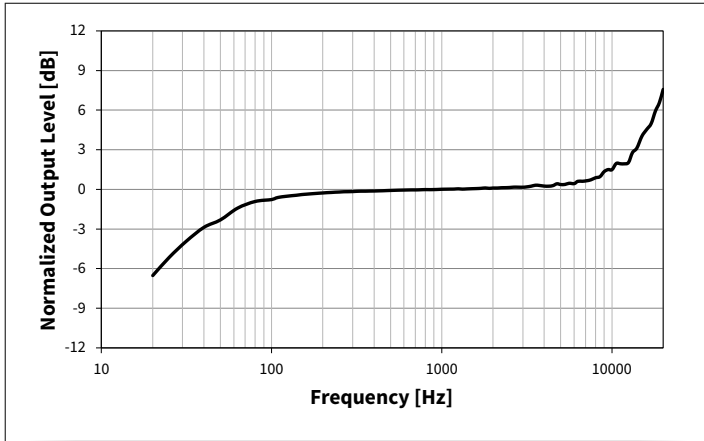

Figure 3 Typical amplitude response

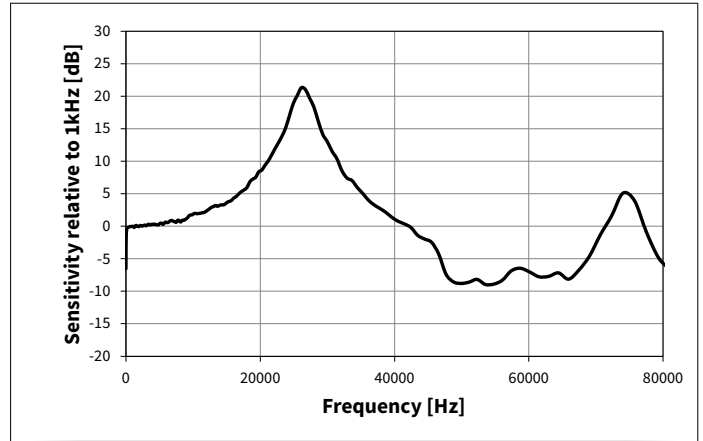

Figure 4 Typical ultrasonic response

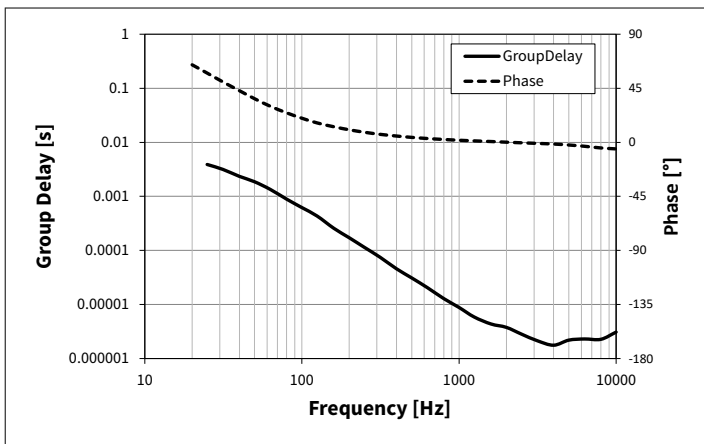

Figure 5 Typical group delay and phase response

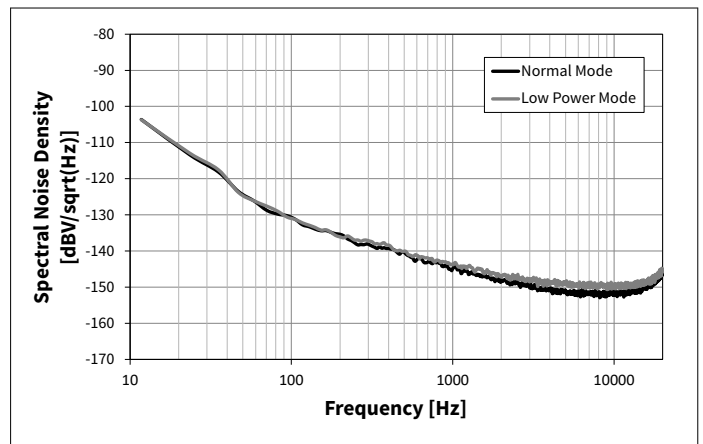

Figure 6 Typical noise floor (unweighted)

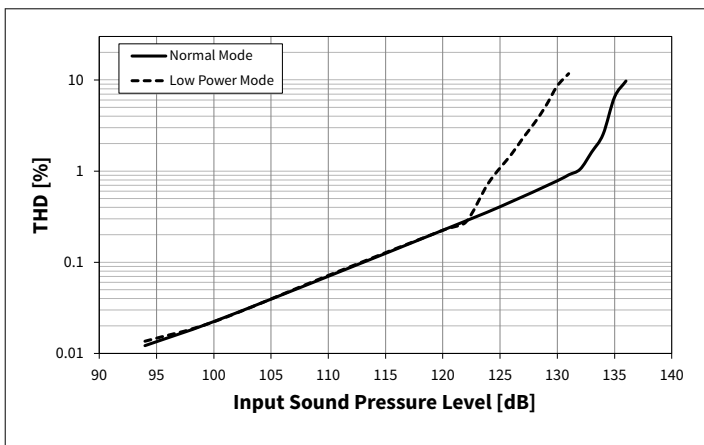

Figure 7 Typical THD vs SPL

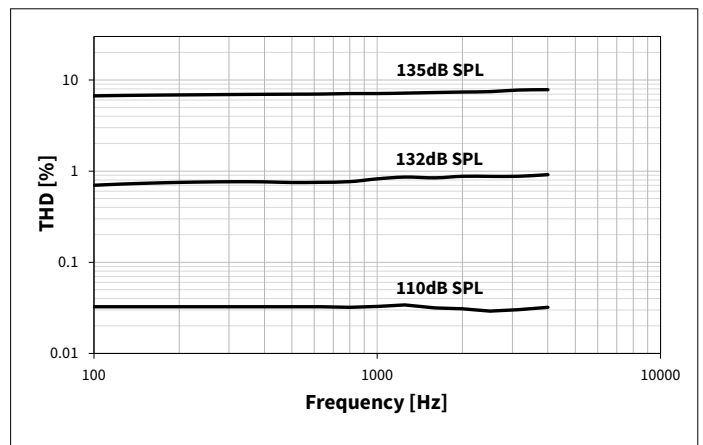

Figure 8 Typical THD vs frequency

3 Typical performance characteristics

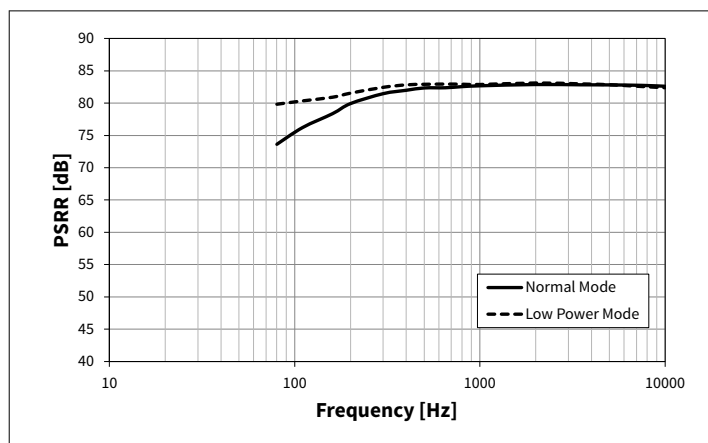

Figure 9 Typical PSRR

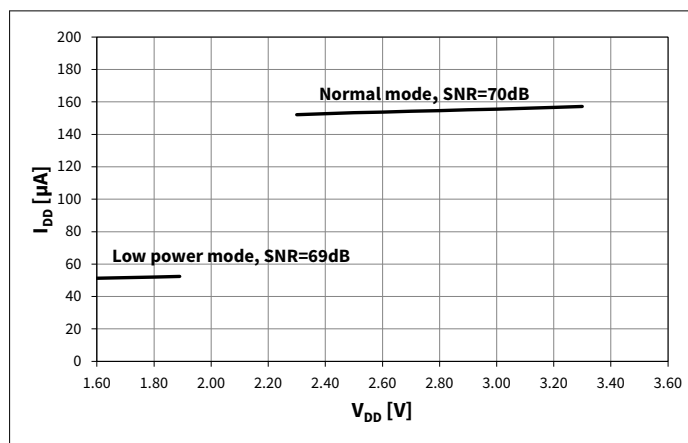

Figure 10 Typical I_{DD} vs V_{DD}

4 Acoustic characteristics

Test conditions (unless otherwise specified in the table): $V_{DD} = 2.75V$, $T_A = 25^\circ C$, 55% R.H., audio bandwidth 20Hz to 20kHz, output unloaded

Table 1 IM70A135V01 acoustic specifications

Parameter		Symbol	Values			Unit	Note or test condition
			Min.	Typ.	Max.		
Sensitivity		S	-39	-38	-37	dBV	1kHz, 94 dB SPL, all operating modes
Low Frequency Roll-off		f_{CLP}		37		Hz	-3dB point relative to 1kHz
Signal to Noise Ratio	Normal mode	SNR_{NP}		70		dB(A)	A-Weighted
	Low power mode	SNR_{LP}		69			
Total Harmonic Distortion	Normal mode	THD_{NP}	94dB SPL		0.3	%	Measuring 2nd to 5th harmonics, 1kHz, Sensitivity=typical
			132dB SPL		1.0		
	Low power mode	THD_{LP}	94dB SPL		0.3		
			124dB SPL		1.0		
Acoustic Overload Point (Typical THD = 10%)	Normal mode	AOP_{NP}		135		dB SPL	
	Low power mode	AOP_{LP}		130			
Phase Response	75Hz			25		°	
	1kHz			2			
	4kHz			-2			
Group Delay	250Hz			125		μs	
	600Hz			22			
	1kHz			8			
	4kHz			1			
Directivity			Omnidirectional				Pickup pattern
Polarity			Increasing V_{out}				Increasing SPL

4.1 Free field frequency response

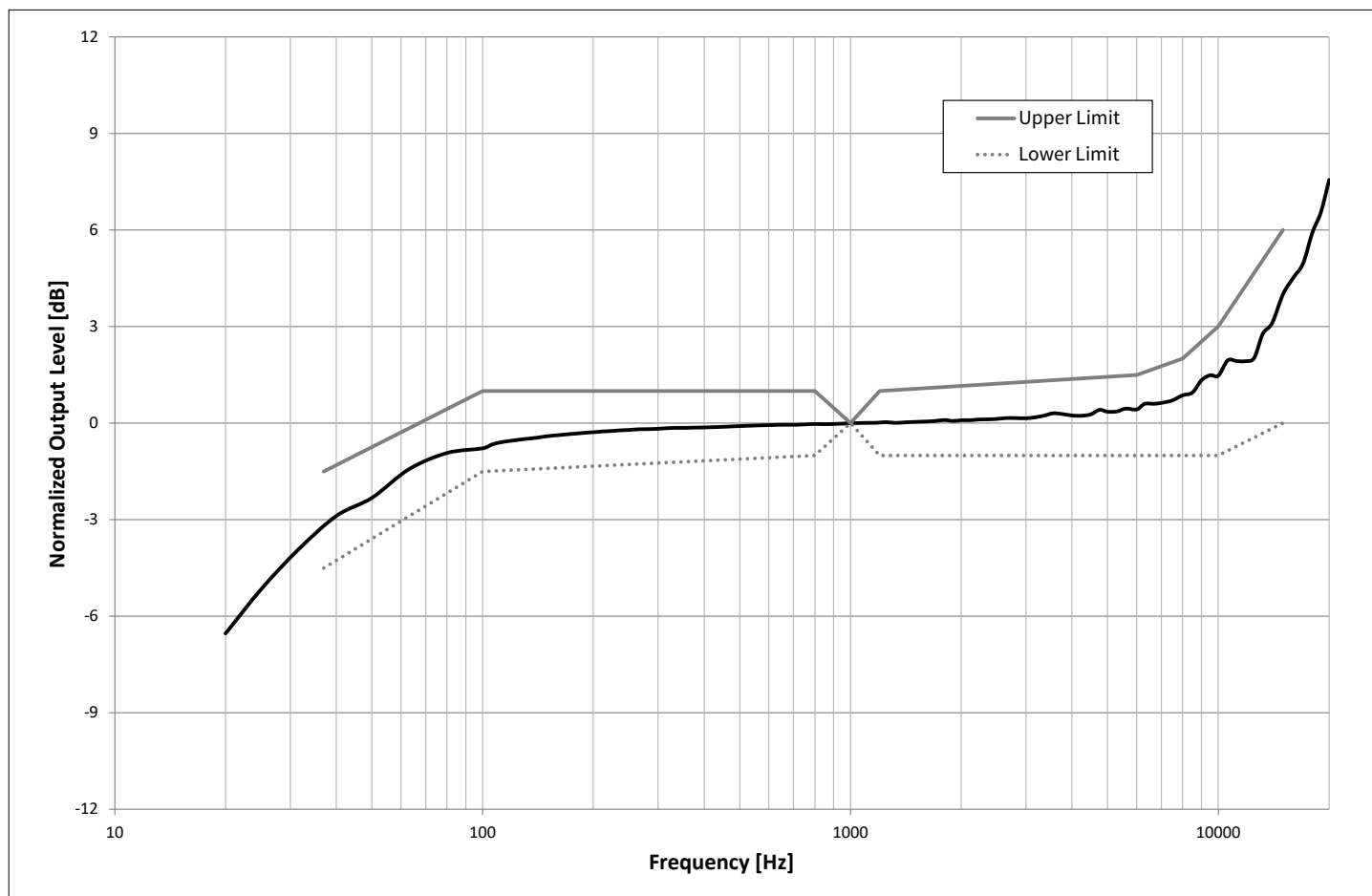

Figure 11 IM70A135V01 free field frequency response

Table 2 IM70A135V01 free field frequency response, normalized to 1kHz sensitivity value

Frequency [Hz]	Upper limit [dB]	Lower limit [dB]
37	-1.5	-4.5
100	1	-1.5
300	1	-1
1000	0	0
6000	1.5	-1
8000	2	-1
10000	3	-1
15000	6	0

5 Electrical characteristics and parameters

5.1 Absolute maximum ratings

Stresses at or above the listed maximum ratings may affect device reliability or cause permanent device damage. Functional device operation at these conditions is not guaranteed.

Table 3 Absolute maximum ratings

Parameter	Symbol	Values		Unit	Note / Test Condition
		Min.	Max.		
Supply voltage	V_{DDmax}		3.0	V	
Storage temperature	T_S	-40	100	°C	
Operating temperature	T_A	-40	85	°C	

5.2 Electrical characteristics

Test conditions (unless otherwise specified in the table): $V_{DD} = 2.75V$, $T_A = 25^\circ C$, 55% R.H.

Table 4 IM70A135V01 electrical characteristics

Parameter		Symbol	Values			Unit	Note / Test Condition
			Min.	Typ.	Max.		
Current consumption	Normal mode	I_{DDNP}		170	230	μA	Input ≤ 94 dB SPL
	Low power mode	$I_{DDL P}$		70	80		
Start-up time		$t_{startup}$		10	30	ms	Start-up time in all operating modes after V_{DDmin} is applied
Mode switching time		$t_{ModeChange}$		10		ms	Time of undefined output after mode change detected
Brown out voltage		$V_{BrownOut}$		1.2		V	Brown out is triggered for voltage below $V_{BrownOut}$
Vout DC-voltage	Normal mode	$V_{OUT_DC_NP}$		1.35		V	
	Low power mode	$V_{OUT_DC_LP}$		0.9			
Power supply rejection ratio in band (differential)	Normal mode	$PSRR_{InBand_N P}$		80		dB	$V_{DD}=2.75V + 100mV_{pp}$ sinewave
	Low power mode	$PSRR_{InBand_L P}$		80			$V_{DD}=1.6V + 100mV_{pp}$ sinewave
Power supply rejection ratio common mode	Normal mode	$PSRR_{CM_NP}$		65		dB	$V_{DD}= 2.75 V + 100mV_{pp}$ sinewave
	Low power mode	$PSRR_{CM_LP}$		60			$V_{DD}= 1.6 V + 100mV_{pp}$ sinewave
Output impedance	Normal mode	Z_{out_NP}			250	Ω	
	Low power mode	Z_{out_LP}			500	Ω	

5.3 Electrical parameters

Table 5 IM70A135V01 electrical parameters

Parameter		Symbol	Values			Unit	Note / Test Condition
			Min.	Typ.	Max.		
Supply voltage	Normal mode	VDD	2.3	2.75	3.0	V	A 100nF bypass capacitor(C_{VDD}) should be placed close to the microphone V_{DD} pin to ensure best SNR performance
	Low power mode		1.52	1.6	1.8		
V _{DD} ramp-up time					1	ms	V _{DD} reaches its final value within ± 10 % tolerance
Output load	C _{load}				100	pF	
	R _{load}			25		kΩ	

6 Package information

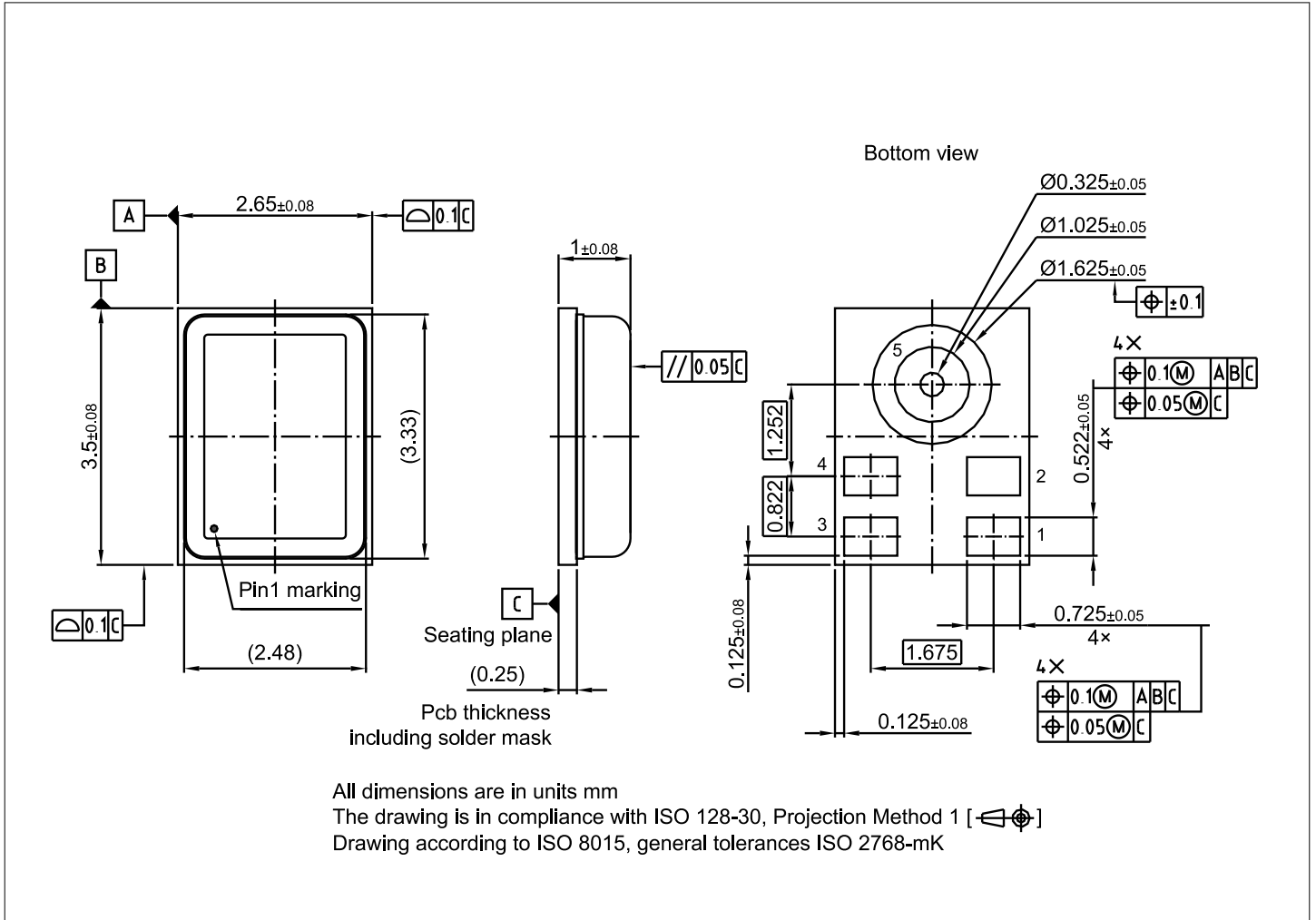

Figure 12 IM70A135V01 package drawing

Table 6 IM70A135V01 pin configuration

Pin Number	Name	Description
1	V _{DD}	Power supply
2	GND	Ground
3	Output +	Differential Output +
4	Output -	Differential Output -
5	GND	Ground

7 Footprint and stencil recommendation

The acoustic port hole diameter in the PCB should be larger than the acoustic port hole diameter of the MEMS microphone to ensure optimal performance. A PCB sound port size of diameter 0.6 mm is recommended.

The board pad and stencil aperture recommendations shown in [Figure 13](#) are based on Solder Mask Defined (SMD) pads. The specific design rules of the board manufacturer should be considered for individual design optimizations or adaptations.

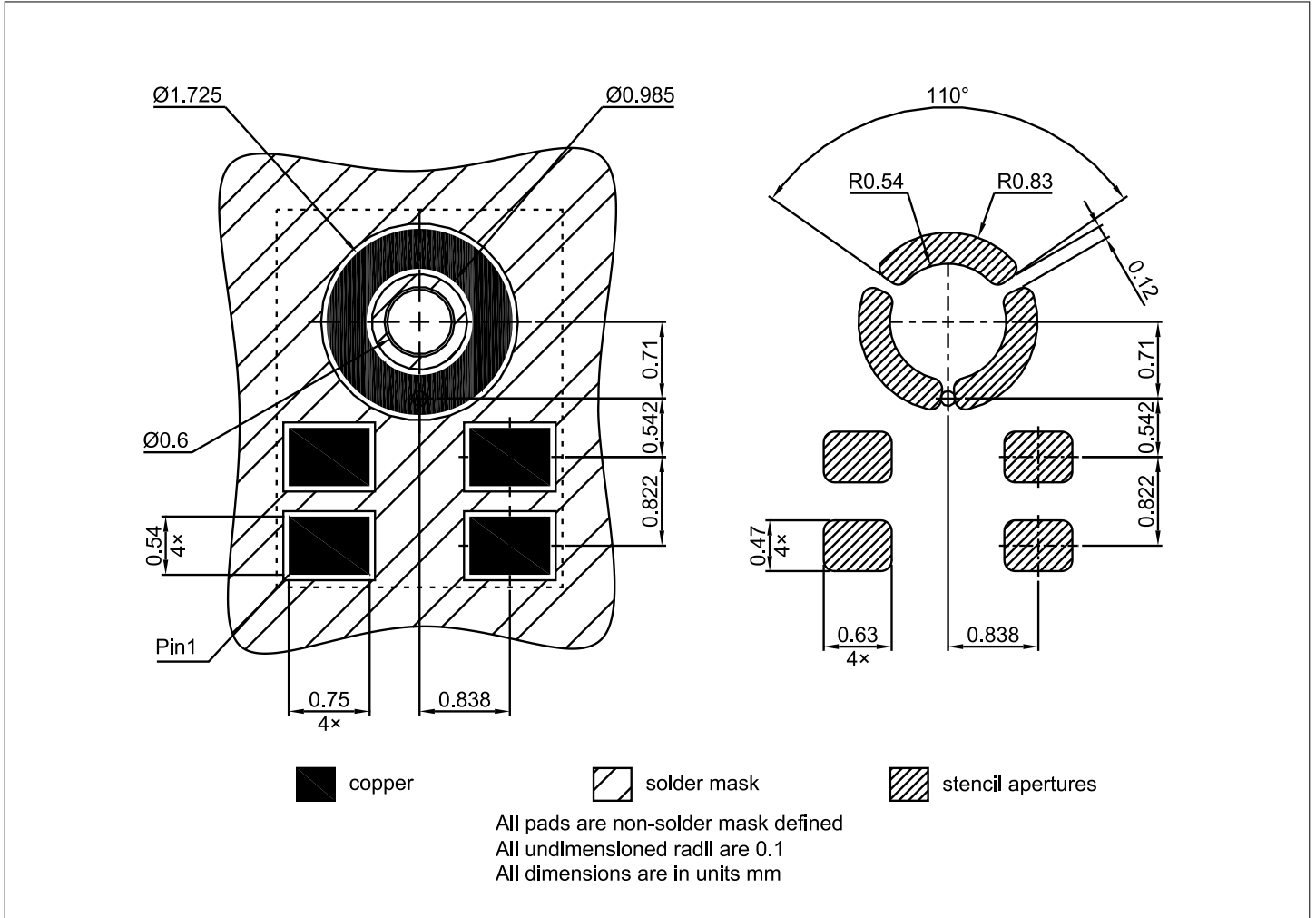

Figure 13 Footprint and stencil recommendation

8 Packing information

For shipping and assembly the Infineon microphones are packed in product specific tape-and-reel carriers. A detailed drawing of the carrier can be seen in [Figure 14](#)

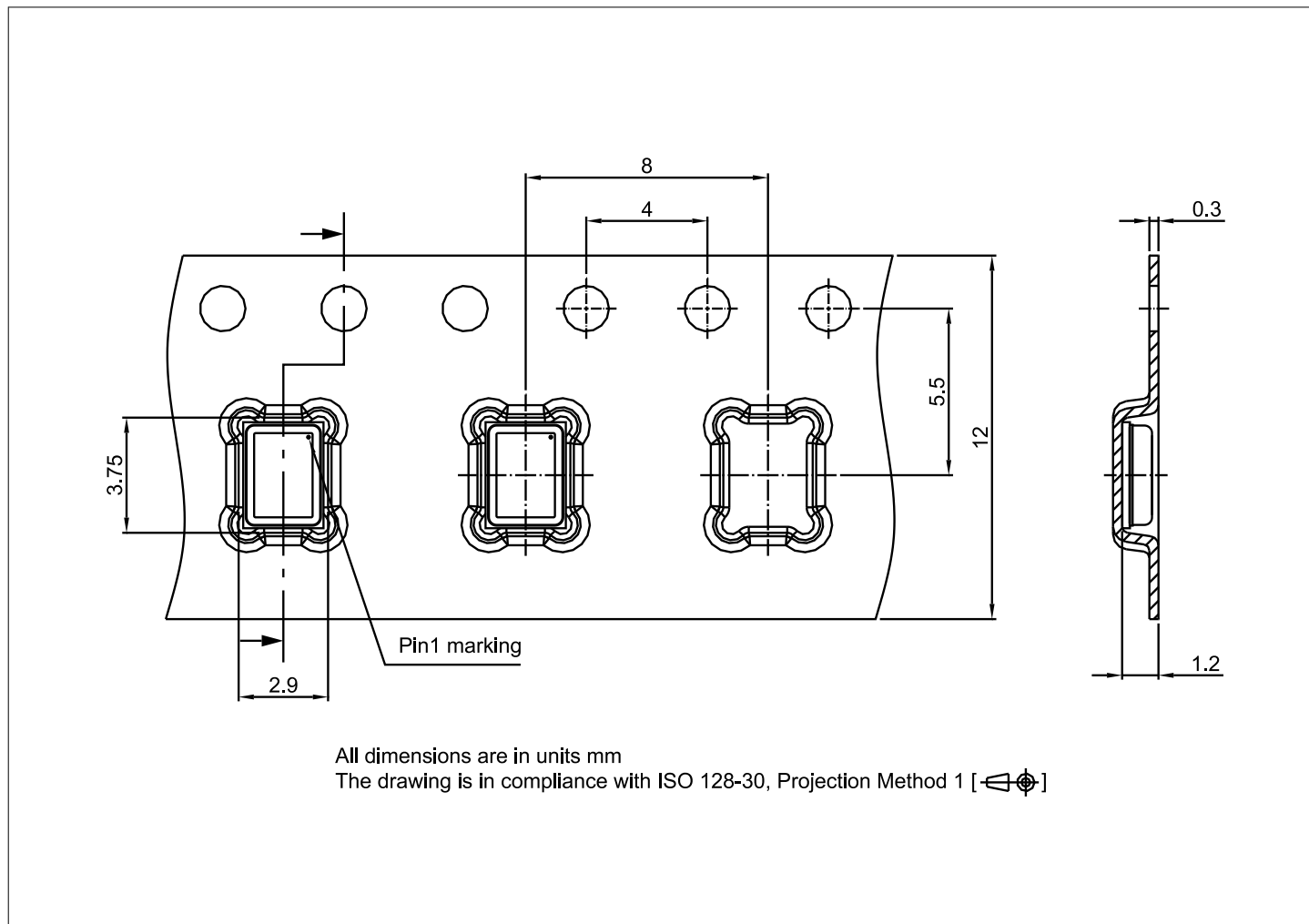

Figure 14 IM70A135V01 tape and reel packing information

Table 7 IM70A135V01 packaging information

Product	Type code	Reel diameter	Quantity per reel
IM70A135V01	I70A13	13"	5000

9 Reflow soldering and board assembly

Infineon MEMS microphones are qualified in accordance with the IPC/JEDEC J-STD-020D-01. The moisture sensitivity level of MEMS microphones is rated as MSL1. For PCB assembly of the MEMS microphone the widely used reflow soldering using a forced convection oven is recommended.

The soldering profile should be in accordance with the recommendations of the solder paste manufacturer to reach an optimal solder joint quality. The reflow profile shown in Figure 15 is recommended for board manufacturing with Infineon MEMS microphones.

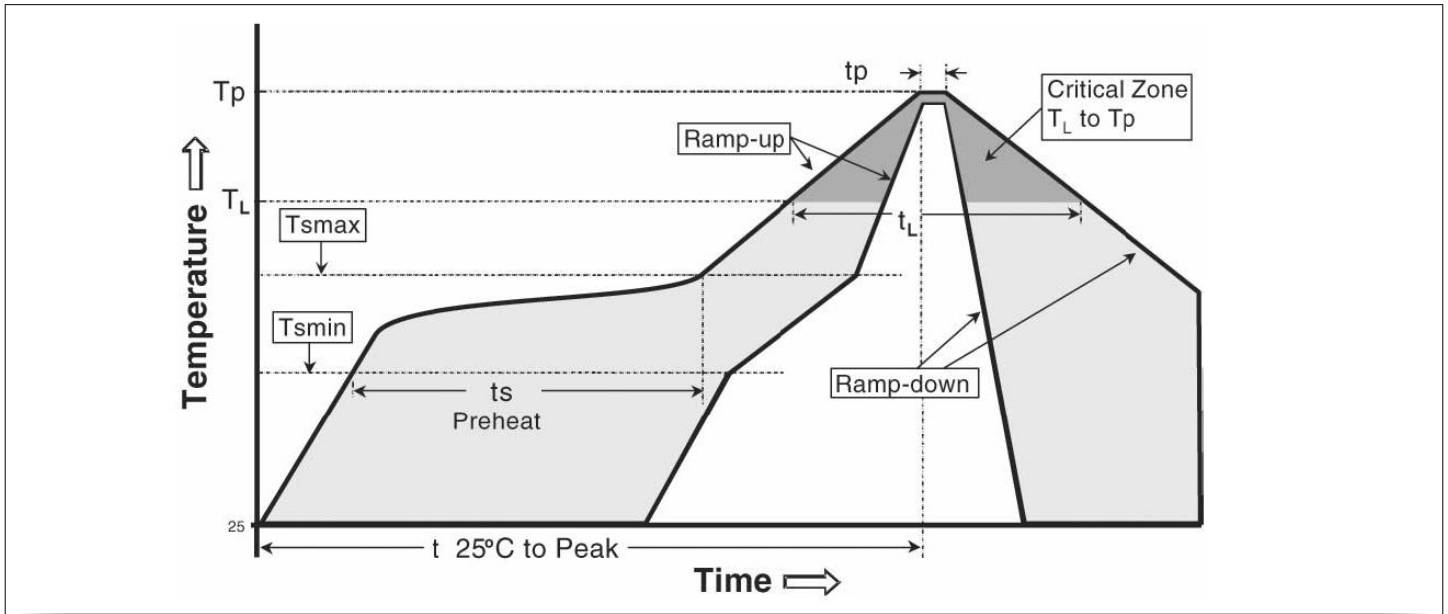

Figure 15 Recommended reflow profile

Table 8 Reflow profile limits

Profile feature	Pb-Free assembly	Sn-Pb Eutectic assembly
Temperature Min (T_{smin})	150 °C	100 °C
Temperature Max (T_{smax})	200 °C	150 °C
Time (T_{smin} to T_{smax}) (t_s)	60-120 seconds	60-120 seconds
Ramp-up rate (T_L to T_p)	3 °C/second max.	3 °C/second max.
Liquidous temperature (T_L)	217 °C	183 °C
Time (t_L) maintained above T_L	60-150 seconds	60-150 seconds
Peak Temperature (T_p)	260°C +0°C/-5°C	235°C +0°C/-5°C
Time within 5°C of actual peak temperature (t_p) ¹⁾	20-40 seconds	10-30 seconds
Ramp-down rate	6 °C/second max.	6 °C/second max.
Time 25°C to peak temperature	8 minutes max.	6 minutes max.

1) Tolerance for peak profile temperature (T_p) is defined as a supplier minimum and a user maximum

Note: For further information please consult the 'General recommendation for assembly of Infineon packages' document which is available on the Infineon Technologies [web page](#)

The MEMS microphones can be handled using industry standard pick and place equipment. Care should be taken to avoid damage to the microphone structure as follows:

- Do not pick the microphone with vacuum tools which make contact with the microphone acoustic port hole.
- The microphone acoustic port hole should not be exposed to vacuum, this can destroy or damage the MEMS.
- Do not blow air into the microphone acoustic port hole. If an air blow cleaning process is used, the port hole must be sealed to prevent particle contamination.
- It is recommended to perform the PCB assembly in a clean room environment in order to avoid microphone contamination.
- Air blow and ultrasonic cleaning procedures shall not be applied to MEMS Microphones. A no-clean paste is recommended for the assembly to avoid subsequent cleaning steps. The microphone MEMS can be severely damaged by cleaning substances.
- To prevent the blocking or partial blocking of the sound port during PCB assembly, it is recommended to cover the sound port with protective tape during PCB sawing or system assembly.
- Do not use excessive force to place the microphone on the PCB. The use of industry standard pick and place tools is recommended in order to limit the mechanical force exerted on the package.

10 Reliability specifications

The microphone sensitivity after stress must deviate by no more than 3dB from the initial value.

Table 9 Reliability specification

Test	Abbreviation	Test Condition	Standard
Low Temperature Operating Life	LTOL	$T_a = -40^\circ\text{C}$, VDD=3.6V, 1000 hours	JESD22-A108
Low Temperature Storage Life	LTSL	$T_a = -40^\circ\text{C}$, 1000 hours	JESD22-A119
High Temperature Operation Life	HTOL	$T_a = +125^\circ\text{C}$, VDD=3.6V, 1000 hours	JESD22-A108
High Temperature Storage Life	HTSL	$T_a = +125^\circ\text{C}$, 1000 hours	JESD22-A103
Temperature Cycling	PC + TC	Pre conditioning MSL-1	JESD22-A113
		1000 cycles, -40°C to $+125^\circ\text{C}$, 30 minutes per cycle	JESD22-A104
Temperature Humidity Bias	PC + THB	Pre conditioning MSL-1	JESD22-A113
		$T_a = +85^\circ\text{C}$, R.H = 85%, VDD=3.6V, 1000 hours	JESD22-A101
Vibration Test	VVF	20Hz to 2000Hz with a peak acceleration of 20g in X, Y, and Z for 4 minutes each, total 4 -cycles	IEC 60068-2-6
Mechanical Shock	MS	10000g/0.1msec direction $\pm x, y, z$, 5 shocks in each direction, 5 shocks in total	IEC 60068-2-27
Reflow Solder ¹⁾	RS	3 reflow cycles, peak temperature = $+260^\circ\text{C}$	IPC-JEDEC J-STD-020D-01
Electrostatic Discharge -System Level Test	ESD - SLT	3 discharges of $\pm 8\text{kV}$ direct contact to lid while V_{dd} is supplied according to the operational modes; (V_{dd} ground is separated from earth ground)	IEC-61000-4-2
Electrostatic Discharge - Human Body Model	ESD - HBM	1 pulse of $\pm 2\text{kV}$ between all I/O pin combinations	JEDEC-JS001
Electrostatic Discharge - Charged Device Model	ESD - CDM	3 discharges of $\pm 500\text{V}$ direct contact to I/O pins.	JEDEC JS-002

1) The microphone sensitivity must deviate by no more than 1dB from the initial value after 3 reflow cycles.

10.1 Environmental robustness

Infineon's latest Sealed Dual Membrane MEMS technology delivers high ingress protection (IP57) at a microphone level. The sealed MEMS design prevents water or dust from entering between membrane and backplate, preventing mechanical blockage or electric leakage issues commonly observed in MEMS microphones. Microphones built with the Sealed Dual Membrane technology can be used to create IP68 devices, requiring only minimal mesh protection.

Table 10 Environmental robustness

Test Standard	Test Condition
IP5x dust resistance ¹⁾	Arizona dust A4 coarse, vertical orientation, sound hole upwards, 10 cycles (15 minutes sedimentation, 6 sec blowing)
IPx7 water immersion ²⁾	Temporary immersion of 1 meters for 30 minutes. Microphone tested 2 hours after removal

1) The number "5" stands for the dust ingress rating or the capacity to withstand the effects of fine, abrasive dust particles.

2) The "7" specifies the higher water immersion rating.

Revision history

Document version	Date of release	Description of changes
V1.00	2023-04-03	Initial datasheet