

Single channel high-side switches

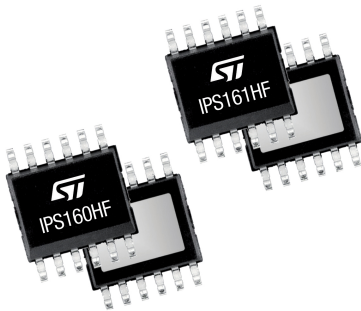

Features

Part number	$R_{DS(on)}$	I_{OUT}	V_{CC}
IPS160HF	0.060 Ω	2.4 A	65 V
IPS161HF		0.6A	

- 8 V to 60 V operating voltage range
- Minimum output current limitation: 0.7A (IPS161HF) or 2.5A (IPS160HF)
- Short propagation delay at start-up
- Fast demagnetization of inductive load
- Non-dissipative short-circuit protection (cut-off)
- Programmable cut-off delay time using external capacitor
- Ground disconnection protection
- V_{CC} disconnection protection
- Thermal shutdown protection
- Undervoltage lock-out
- Diagnostic signalization for: open load in off-state, cut-off and junction thermal shutdown
- Designed to meet IEC 61131-2
- PowerSSO12 package

Applications

- Safety applications
- Programmable logic control
- Industrial PC peripheral input/output
- Numerical control machines

Description

The IPS160HF ($I_{out} = 2.4A$) and IPS161HF ($I_{out} = 0.6A$) are monolithic devices which can drive capacitive, resistive or inductive loads with one side connected to ground.

The 60 V operating range and $R_{on} = 60\text{ m}\Omega$, combined with the extended diagnostic (Open Load, Over Load, Overtemperature) and the $< 60\text{ }\mu\text{s}$ propagation delay time at startup (enabling Class 3 for interface types C and D), make the ICs suitable to address safety applications targeting higher SIL levels.

The built-in overload and thermal shutdown protections guarantee the ICs, the application and the load against electrical and thermal overstress.

Furthermore, in order to minimize the power dissipation when the output is shorted, a low-dissipative short-circuit protection (cut-off) is implemented to limit the output average current value and consequent device overheating.

Cut-off delay time can be set by soldering an external capacitor or disabled by a resistor on pin 4 (CoD).

The DIAG common diagnostic open drain pin reports the open load in off-state, cut-off (overload) and thermal shutdown.

Product status		
IPS160HF		
IPS161HF		

Product summary		
Order code	IPS160HF	IPS160HFTR
	IPS161HF	IPS161HFTR
Package	PowerSSO12	
Packing	Tube	Tape and reel

1 Block diagram

Figure 1. Block diagram

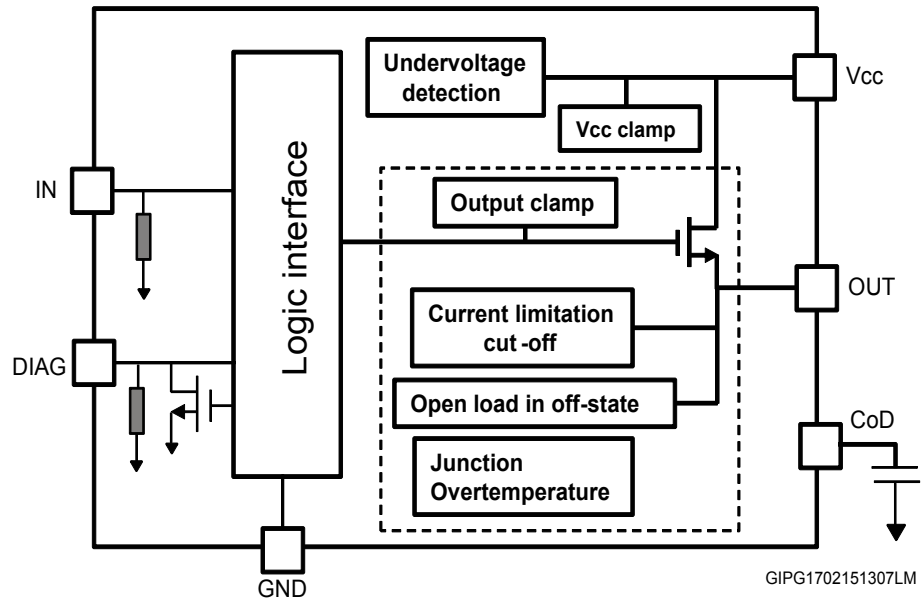

2 Pin description

Figure 2. Pin connection (top view)

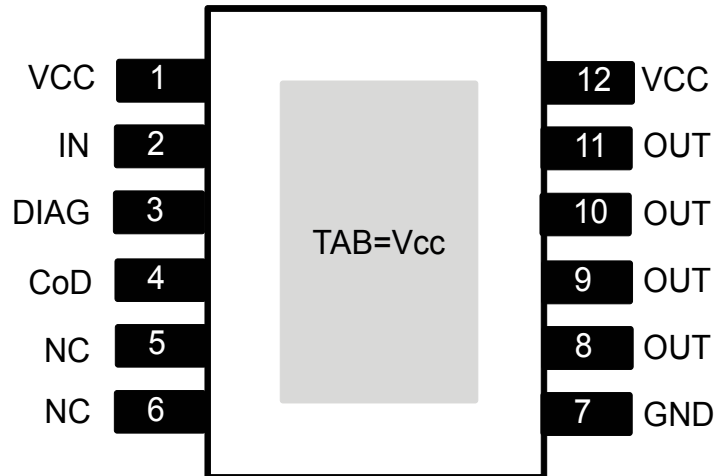

GIPG1702151321LM

Table 1. Pin configuration

Number	Name	Function	Type
1, 12, TAB	VCC	Device supply voltage	Supply
2	IN	Channel input	Input
3	DIAG	Common diagnostic pin for thermal shutdown, cut-off and open load	Output open drain
4	CoD	Cut-off delay pin, cannot be left floating. Connected to GND by 1 kΩ resistor to disable the cut-off function. Connect to a C _{CoD} capacitor to set the cut-off delay see Table 8. Protection and diagnostic	Input
5, 6	NC	Not connected	
7	GND	Device ground	Ground
8, 9, 10, 11	OUT	Channel power stage output	Output

IN This pin drives the output stage to pin OUT. IN pin has internal weak pull-down resistors, see [Table 7. Logic inputs](#).

OUT Output power transistor is in high-side configuration, with active clamp for fast demagnetization.

DIAG This pin is used for diagnostic purposes and is internally wired to an open drain transistor. The open drain transistor is turned on in case of junction thermal shutdown, cut-off, or open load in off-state.

CoD

This pin cannot be left floating and can be used to program the cut-off delay time t_{coff} , see [Table 8. Protection and diagnostic](#) through an external capacitor (C_{CoD}). The cut-off function can be completely disabled by connecting the CoD pin to GND through 1 kΩ resistor: in this condition, the output channel remains in limitation condition, supplying the current to the load until the input is forced LOW or the thermal shutdown threshold is triggered.

GND

IC ground.

The IC can be protected against reverse polarity using two different solutions:

1. Placing a resistor R_{GND} between IC GND pin and load connection point to GND ($R_{\text{GND}} > V_{\text{CC}}/I_{\text{CC}}$, see [Table 2](#). Absolute maximum rating). Note that power dissipated by R_{GND} during reverse polarity condition is $V_{\text{CC}}^2/R_{\text{GND}}$.
2. Placing a diode in parallel to R_{GND}

The diode must be selected such that its $V_{\text{RRM}} > |V_{\text{CC}}|$ and power dissipation capability is higher than $V_{\text{F}} \cdot I_{\text{S}}$ (see [Table 4](#)).

In normal operation (no reverse polarity), there is a voltage drop (ΔV) between GND of the device and GND of the module.

Using option 1, $\Delta V = R_{\text{GND}} \cdot I_{\text{CC}}$.

Using option 2, $\Delta V = V_{\text{F}}@I_{\text{S}}$.

Figure 3. Reverse polarity

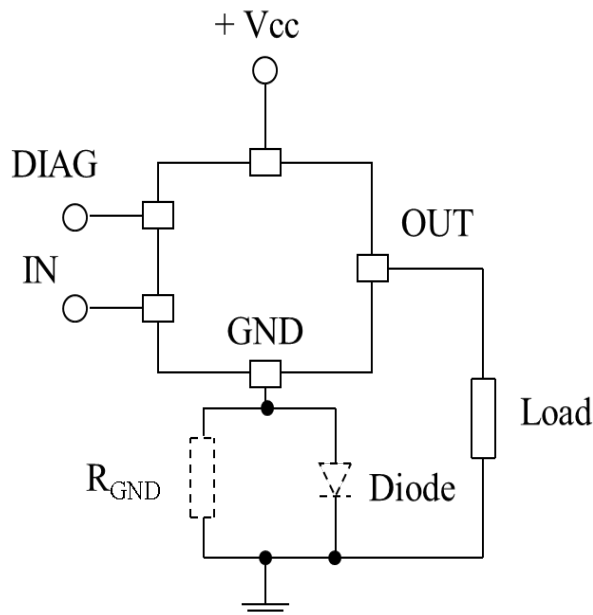

VCC

IC supply voltage.

3 Absolute maximum ratings

Table 2. Absolute maximum ratings

Symbol	Parameter	Value	Unit
V _{CC}	Supply voltage	-0.3 to 65	V
V _{OUT}	Output channel voltage	V _{CC} -V _{clamp} to V _{CC} +0.3	V
I _{IN}	Input current	-10 to +10	mA
V _{IN}	IN voltage	V _{CC}	V
V _{COD}	Output cut-off voltage pin	5.5	V
I _{COD}	Input current on cut-off pin	-1 to +10	mA
V _{DIAG}	Fault voltage	V _{CC}	V
I _{DIAG}	Fault current	-5 to +10	mA
I _{CC} ⁽¹⁾	Maximum DC reverse current flowing through the IC from GND to V _{CC}	-250	mA
I _{OUT}	Output stage current	Internally limited	A
-I _{OUT} ⁽¹⁾	Maximum DC reverse current flowing through the IC from OUT to V _{CC}	5	
E _{AS} ⁽¹⁾	Single pulse avalanche energy (T _{AMB} = 125 °C, V _{CC} = 24 V, I _{load} = 1 A)	1000	mJ
P _{TOT}	Power dissipation at T _C = 25 °C ⁽²⁾	Internally limited	W
T _{STG}	Storage temperature range	-55 to 150	°C
T _J	Junction temperature	-40 to 150	

1. Verified on application board with R_{th(ja)} = 49 °C/W

2. (T_{JSD(MAX)}-T_C)/R_{th(ja)}

Note: Absolute maximum ratings are the values beyond which damage to the device may occur. Functional operation under these conditions is not implied. All voltages are referenced to GND.

Table 3. Thermal data

Symbol	Parameter	Value	Unit
R _{th(jc)}	Thermal resistance junction-case	1	°C/W
R _{th(ja)}	Thermal resistance junction-ambient	49	

Note: Package mounted on a 2-layer application board with Cu thickness = 35 μm, total dissipation area = 1.5 cm² connected by 6 vias.

4 Electrical characteristics

(8 V < V_{CC} < 60 V; -40 °C < T_J < 125 °C, unless otherwise specified)

Table 4. Supply

Symbol	Parameter	Test conditions	Min.	Typ.	Max.	Unit
V _{CC}	Supply voltage		V _{UVON}		60	V
V _{UVON}	Undervoltage on threshold		6.9		8	V
V _{UVOFF}	Undervoltage off threshold		6.5		7.8	V
V _{UVH}	Undervoltage hysteresis		0.15	0.5		V
I _S	Supply current in off-state	V _{CC} = 24 V		300	500	μA
		V _{CC} = 60 V		350	600	
	Supply current in on-state	V _{CC} = 24 V		1	1.4	mA
		V _{CC} = 60 V		1.4	2.1	
I _{LGND}	GND disconnection output current	V _{GND} = V _{IN} = V _{CC} , V _{OUT} = 0 V			1	mA

Table 5. Output stage

Symbol	Parameter	Test conditions	Min.	Typ.	Max.	Unit
R _{DS(on)}	On-state resistance	V _{CC} = 24 V I _{OUT} = 1 A @ T _J = 25 °C		60	80	mΩ
		V _{CC} = 24 V I _{OUT} = 1 A @ T _J = 125 °C			120	
V _{OUT(OFF)}	Off-state output voltage	V _{IN} = 0 V and I _{OUT} = 0 A			2	V
I _{OUT(OFF)}	Off-state output current	V _{CC} = 24 V, V _{IN} = 0 V, V _{OUT} = 0 V			3	μA
		V _{CC} = 60 V, V _{IN} = 0 V, V _{OUT} = 0 V			10	
I _{OUT(OFF-min)}	Off-state output current	V _{IN} = 0 V, V _{OUT} = 4 V	-35		0	

Table 6. Switching (V_{CC} = 24 V; -40 °C < T_J < 125 °C, R_{LOAD} = 48 Ω)

Symbol	Parameter	Test conditions	Min.	Typ.	Max.	Unit
t _r	Rise time	I _{OUT} = 0.5 A, (see Figure 4. Timing in normal operation)		10		μs
t _f	Fall time			10		
t _{PD(H-L)}	Propagation delay time off			20		
t _{PD(L-H)}	Propagation delay time on			30		
t _{D(VCC-ON)}	Power-on delay time from V _{CC} rising edge	I _{OUT} = 0.5 A, (see Figure 5. Propagation delay at start-up)		32	60	

Figure 4. Timing in normal operation

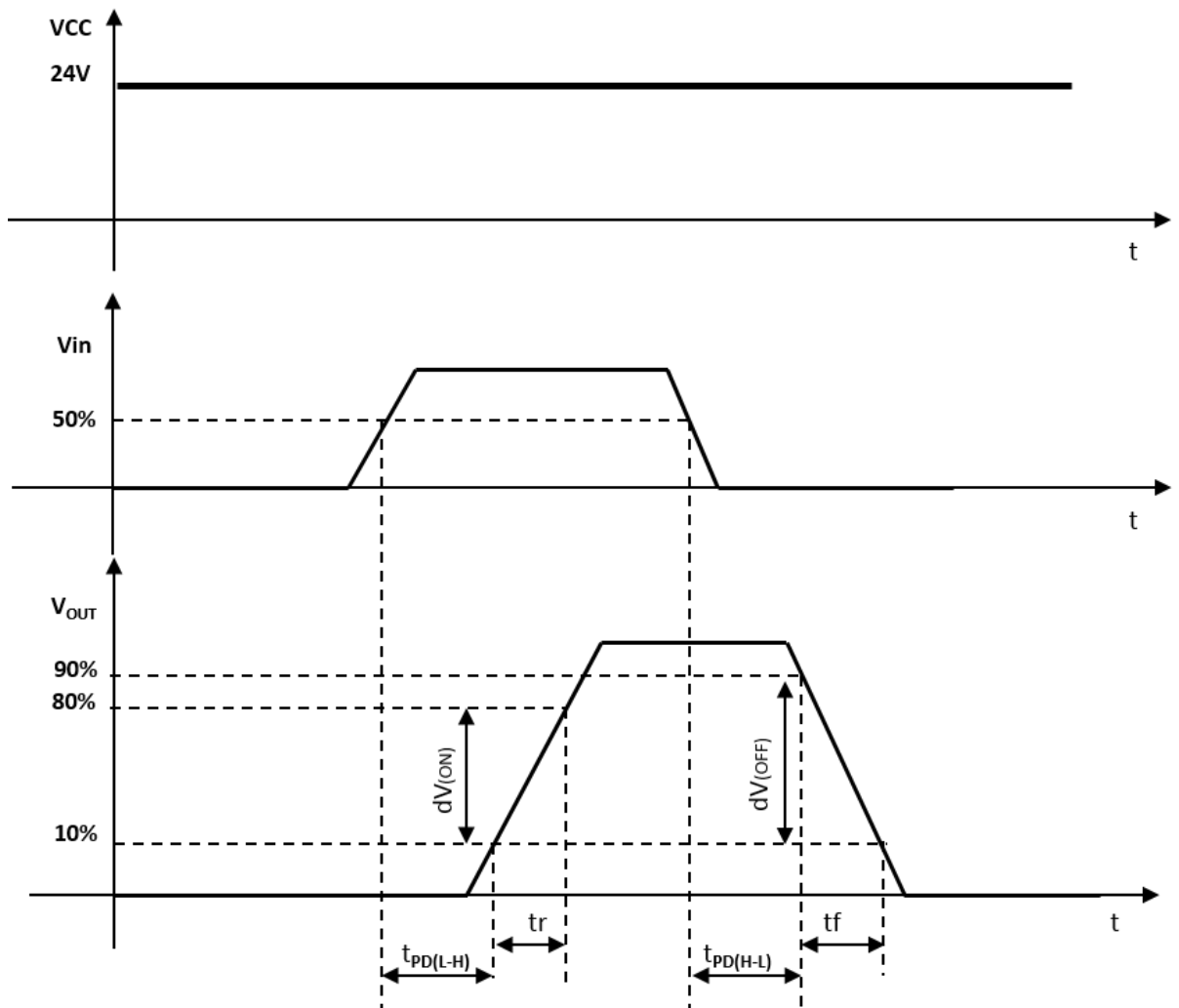

Figure 5. Propagation delay at start-up

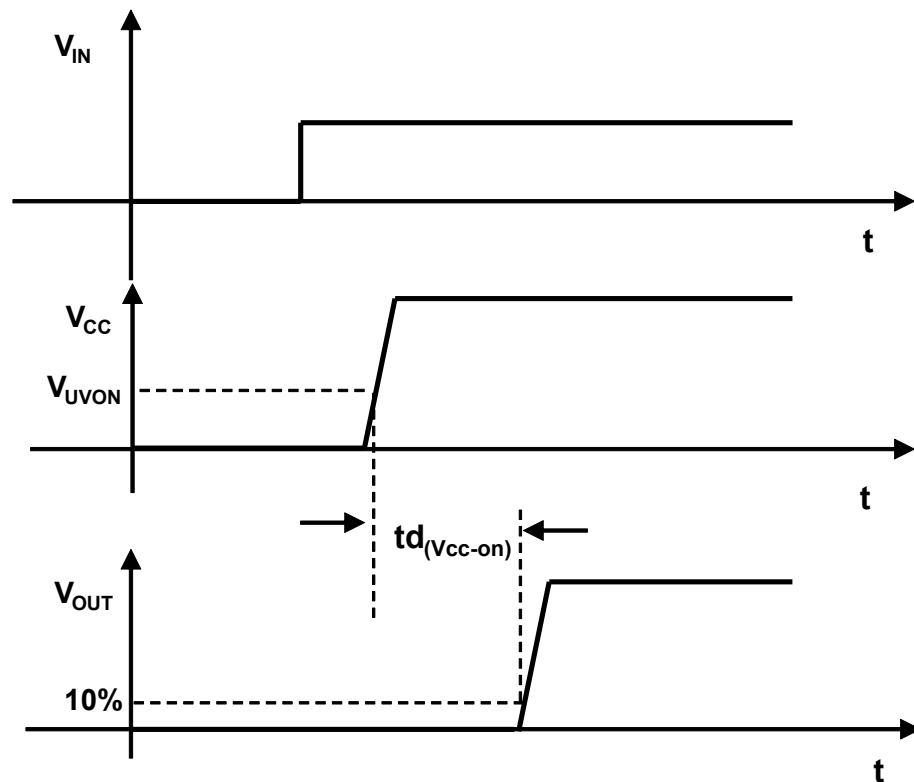

Table 7. Logic inputs

Symbol	Parameter	Test conditions	Min.	Typ.	Max.	Unit
V_{IL}	Input low level voltage				0.8	V
V_{IH}	Input high level voltage		2.2			
$V_{I(HYST)}$	Input hysteresis voltage			0.4		
I_{IN}	Input current	$V_{CC} = V_{IN} = 36\text{ V}$			200	μA
		$V_{CC} = V_{IN} = 60\text{ V}$			550	

Table 8. Protection and diagnostic

Symbol	Parameter	Test conditions	Min.	Typ.	Max.	Unit	
V _{clamp}	V _{CC} active clamp	I _{CC} = 10 mA	65.5	68.5	71.5	V	
V _{demag}	Demagnetization voltage	I _{OUT} = 0.5 A; load = 1 mH	V _{CC} -71.5	V _{CC} -68.5	V _{CC} -65.5		
V _{OLoff}	Open load (off-state) or short to V _{CC} detection threshold		2		4		
t _{BKT}	Open load blanking time				200	μs	
V _{DIAG}	Voltage drop on DIAG	I _{DIAG} = 4 mA			1	V	
I _{DIAG}	DIAG pin leakage current	V _{CC} ≤ 36 V			110	μA	
		36 V < V _{CC} ≤ 60 V			180		
I _{PK}	Output current limitation activation threshold	V _{CC} ≤ 24 V, R _{LOAD} ≤ 10 mΩ	IPS161HF	1.3		2.1	A
			IPS160HF	3.0		4.6	
I _{LIM}	Output current limitation		IPS161HF	0.7		1.7	
			IPS160HF	2.5		4.2	
t _{coff}	Cut-off current delay time	Programmable by the external capacitor on CoD pin. Cut-off is disabled when CoD pin is connected to GND through 1 kΩ resistor. T _J < T _{JSD}	50x C _{COFF} [nF] ± 35% ⁽¹⁾			μs	
t _{res}	Output stage restart delay time	T _J < T _{JSD}	32xt _{COFF} [μs] ± 40%				
T _{JSD}	Junction temperature shutdown		150	170	190	°C	
T _{JHYST}	Junction temperature thermal hysteresis			15			

1. The formula is guaranteed in the range 10 nF ≤ C_{COFF} ≤ 100 nF.

5 Output logic

Table 9. Output stage truth table

Operation	IN	OUT	DIAG
Normal	L	L	H
	H	H	H
Cut-off	L	L	L
	H	L	L
Overtemperature	L	L	L
	H	L	L
Open load	L	H ⁽¹⁾	L ⁽¹⁾
	H	H	H
UVLO	X	L	X
	X	L	X

1. External pull-up resistor is used

6 Protection and diagnostic

The IC integrates several protections to ease the design of a robust application.

6.1 Undervoltage lock-out

The device turns off if the supply voltage falls below the turn-off threshold ($V_{UV(off)}$). Normal operation restarts after V_{CC} exceeds the turn-on threshold ($V_{UV(on)}$). Turn-on and turn-off thresholds are defined in [Table 4. Supply](#).

6.2 Overtemperature

The output stage turns off when its internal junction temperature (T_J) exceeds the shutdown threshold T_{JSD} . Normal operation restarts when T_J comes back below the reset threshold ($T_{JSD} - T_{JHYST}$), see [Table 8. Protection and diagnostic](#). The internal fault signal is set when the channel is off due to thermal protection and it is reset when the junction triggers the reset threshold. This same behavior is signaled on the DIAG pin.

6.3 Cut-off

The IC can limit the output current at the power stage by its embedded output current limitation circuit. This circuit continuously monitor the output current and, when load is increasing, at the triggering of its activation threshold (I_{pk}) it starts limiting to I_{LIM} limitation level: while current limitation is active the IC enters an high dissipation status.

The IPS160HF implements the cut-off feature which limits the duration of the current limitation condition.

The duration of the current limitation condition (t_{COFF}) can be set by a capacitor (C_{CoD}) placed between CoD and GND pins. The design rule for C_{CoD} is:

$$t_{COFF[us]} \pm 35\% = 50 \times C_{CoD[nF]}$$

The $\pm 35\%$ drift is guaranteed in the range of $10 \text{ nF} < C_{CoD} < 100 \text{ nF}$; lower capacitance than 10 nF can be used.

If I_{LIM} threshold is triggered, the output stage remains in the current limitation condition ($I_{OUT} = I_{LIM}$) no longer than t_{COFF} . If t_{COFF} elapses, the output stage turns off and restarts after the t_{RES} restart time.

Thermal shutdown protection has higher priority than cut-off:

- IC is forced off if T_{JSD} is triggered before t_{COFF} elapses
- if T_{JSD} is triggered, IC is maintained off even after the t_{RES} has elapsed and until the T_J falls below $T_{JSD} - T_{JHYST}$

Figure 6. Current limitation and cut-off

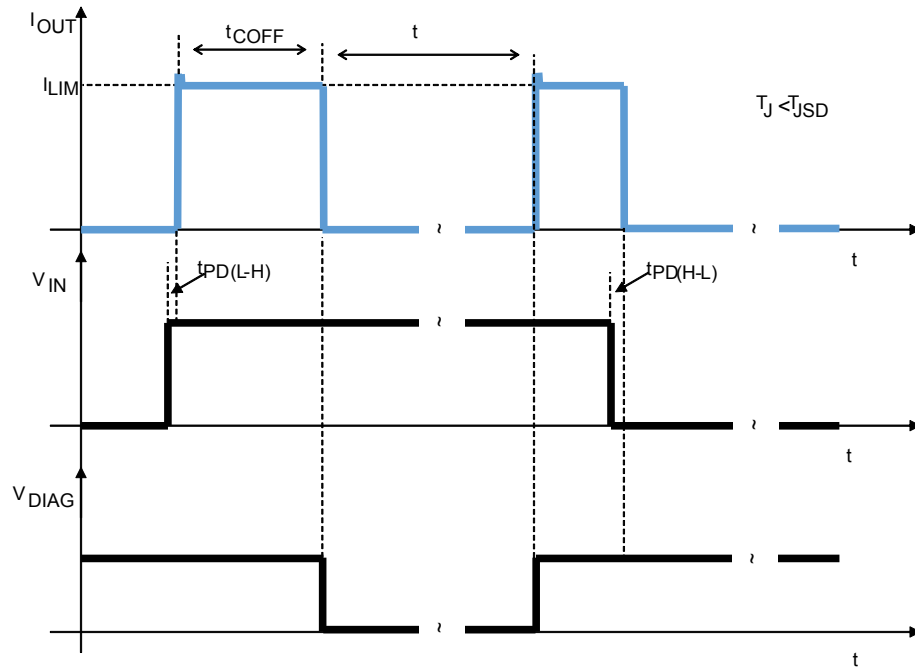

The fault condition is reported on the DIAG pin. The internal cut-off flag signal is latched at output switch-off and released after the time t_{RES} , the same behavior is signaled on DIAG pin.

The status of the DIAG is independent on the IN pin status.

If CoD pin is connected to GND through 1 k Ω resistor (cut-off feature disabled), when the output channel triggers the limitation threshold, it remains on, in current limitation condition, until the input becomes LOW or the thermal protection threshold is triggered.

In case of low ambient temperature conditions ($T_{AMB} < -20\text{ }^\circ\text{C}$) and high supply voltage ($V_{CC} > 36\text{ V}$), the cut-off function requires activation in order to avoid damaging the IC.

The following table shows the suggested cut-off delay for different operating voltages.

Table 10. Minimum cut-off delay for T_{AMB} less than $-20\text{ }^\circ\text{C}$

V_{CC} [V]	Cut-off delay [μs]	Cut-off capacitance [nF]
36-48	100	2.2
48-60	50	1

6.4 Open load in off-state

The IC provides the open load detection feature which detects if the load is disconnected from the OUT pin. This feature can be activated by a resistor (R_{PU}) between OUT and VCC pins.

Figure 7. Open load off-state

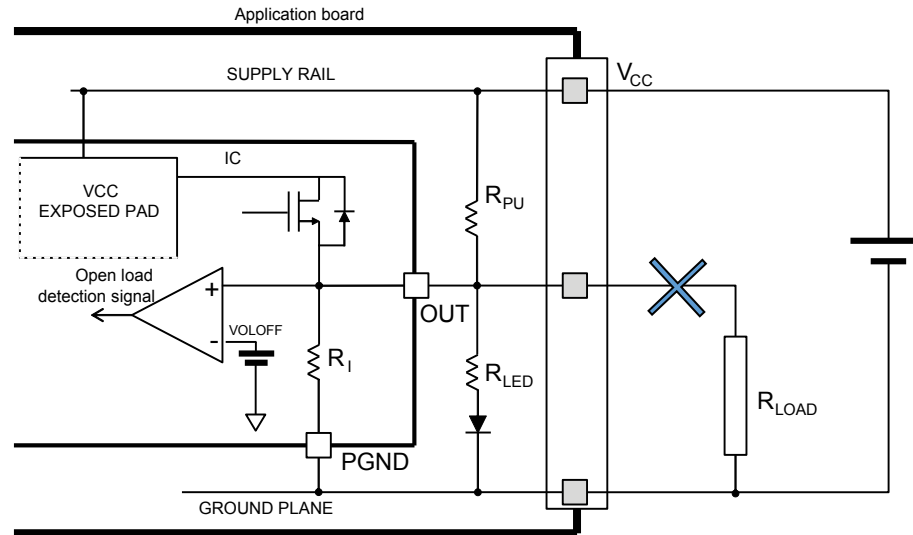

In case of wire break and during the OFF state ($IN = low$), the output voltage V_{OUT} rises according to the partitioning between the external pull-up resistor and the internal impedance of the IC ($130\text{ k}\Omega < R_I < 360\text{ k}\Omega$).

The effect of the LED (if any) on the output pin has to be considered as well. In case of wire break and during the ON state ($IN = high$), the output voltage V_{OUT} is pulled up to V_{CC} by the low resistive integrated switch. If the load is not connected, in order to guarantee the correct open load signalization it must result:

$$V_{OUT} > V_{OLoff(max)}$$

Referring to the circuit in Figure 7. Open load off-state:

$$V_{OUT} = V_{CC} - R_{PU} \times I_{PU} = V_{CC} - R_{PU} \times (I_{RI} + I_{LED} + I_{RL}) \quad (1)$$

therefore:

$$R_{PU} < \frac{V_{CC(min)} - V_{OLoff(max)}}{\left(\frac{V_{OLoff(max)}}{R_I(min)} + \frac{V_{OLoff(max)} - V_{LED}}{R_{LED}}\right)} \quad (2)$$

If the load is connected, in order to avoid any false signalization of the open load, the following condition must hold:

$$V_{OUT} < V_{OLoff(min)}$$

By taking into account the circuit in figure 6:

$$V_{OUT} = V_{CC} - R_{PU} \times I_{PU} = V_{CC} - R_{PU} \times \left(\frac{V_{OUT}}{R_I} + \frac{V_{OUT} - V_{LED}}{R_{LED}} + \frac{V_{OUT}}{R_L}\right) \quad (3)$$

so:

$$R_{PU} > \frac{V_{CC(max)} - V_{OLoff(min)}}{\left(\frac{V_{OLoff(min)}}{R_I(max)} + \frac{V_{OLoff(min)} - V_{LED}}{R_{LED}} + \frac{V_{OLoff(min)}}{R_L}\right)} \quad (4)$$

The fault condition is signaled on the DIAG pin and the fault reset occurs when load is reconnected.

If the channel is switched on by the IN pin, the fault condition is no longer detected.

When an inductive load is driven, some ringing of the output voltage may be observed at the end of the demagnetization. In fact, the load is completely demagnetized when $I_{LOAD} = 0$ A and the OUT pin remains floating until next turn-on. In order to avoid false detection of the open load event when driving inductive loads, the open load signal is masked for t_{BKT} . So, the open load is reported on the DIAG pin with a delay of t_{BKT} and if the open load event is triggered for more than t_{BKT} .

6.5 VCC disconnection protection

The IC is protected despite the V_{CC} disconnection event. This event is intended as the disconnection of the V_{CC} wire from the application board, see figure below. When this condition happens, the IC continues working normally until the voltage on the V_{CC} pin is $\geq V_{UVOFF}$. Once the V_{UVOFF} is triggered, the output channel is turned off independently on the input status. In case of inductive load, if the V_{CC} is disconnected while the output channel is still active, the IC allows the discharge of the energy still stored in the inductor through the integrated power switch.

Figure 8. VCC disconnection
APPLICATION BOARD

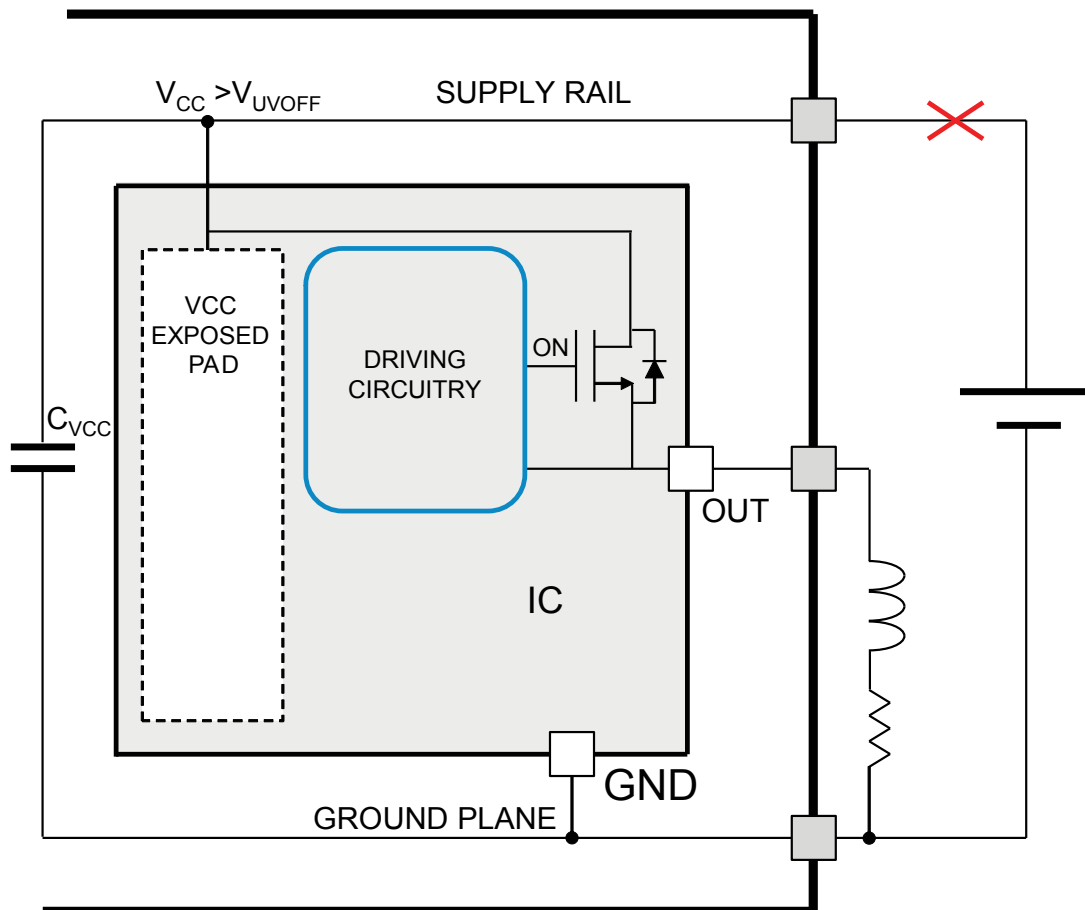

6.6 GND disconnection protection

GND disconnection is intended as the disconnection event of the application ground, see figure below. When this event happens, the IC continues working normally until the voltage between V_{CC} and GND pins of the IC is $\geq V_{UVOFF}$. The voltage on GND pin of the IC rises up to the supply rail voltage level. In case of GND disconnection event, a current (I_{LGND}) flows through OUT pin. Table 4. Supply shows $I_{OUT} = I_{LGND}$ for the worst case GND disconnection event where the output is shorted to ground.

Figure 9. GND disconnection
APPLICATION BOARD

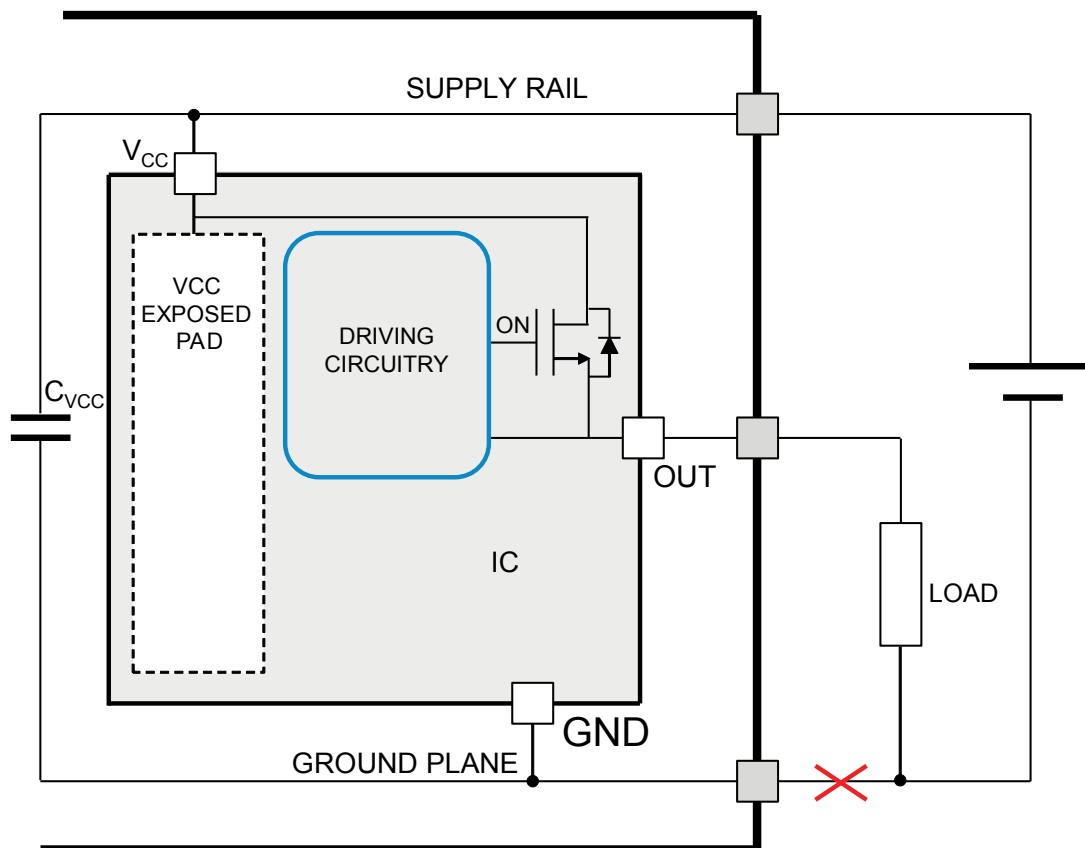

7 Active VDS clamp

Active clamp is also known as fast demagnetization of inductive loads or fast current decay. When a high-side driver turns off an inductance, an undervoltage is detected on output.

The OUT pin is pulled down to V_{demag} . The conduction state is modulated by internal circuitry in order to keep the OUT pin voltage at about V_{demag} until the load energy has been dissipated. The energy is dissipated both in the IC internal switch and in the load resistance.

Figure 10. Active clamp equivalent principle schematic

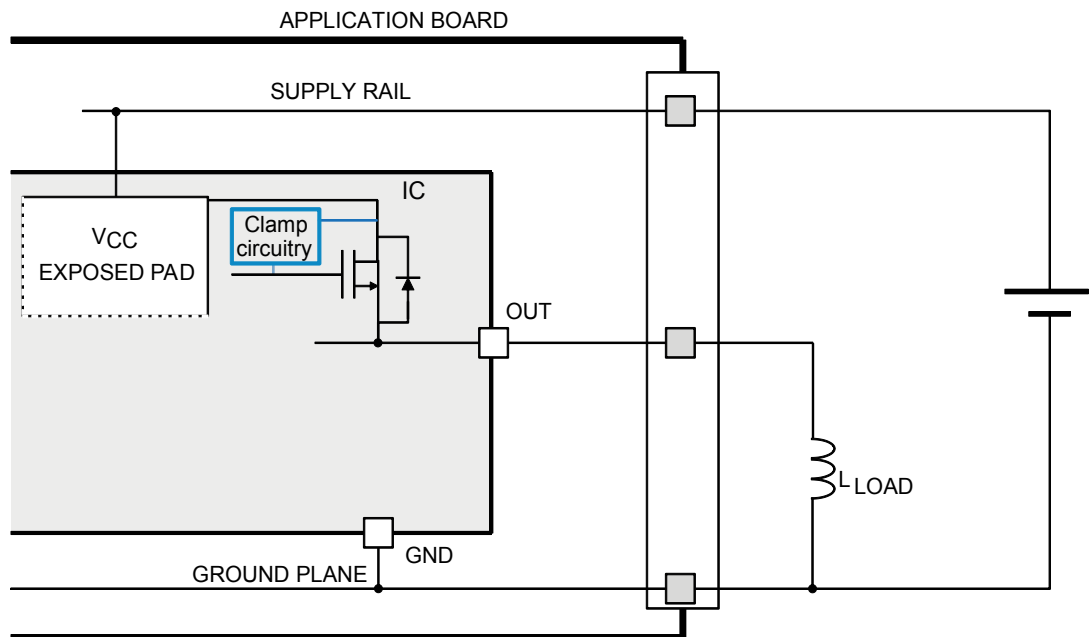
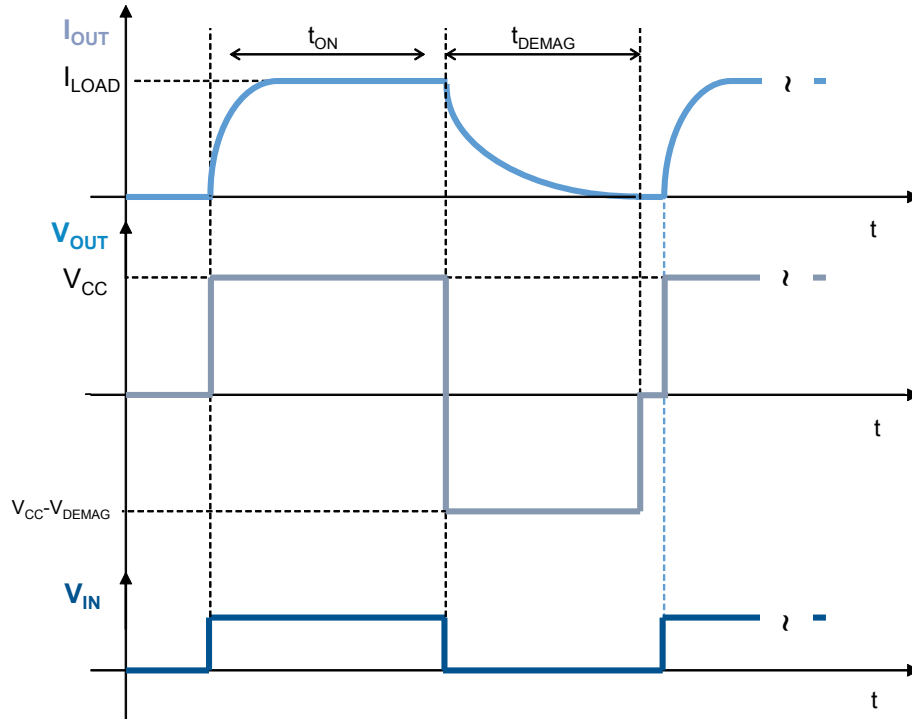
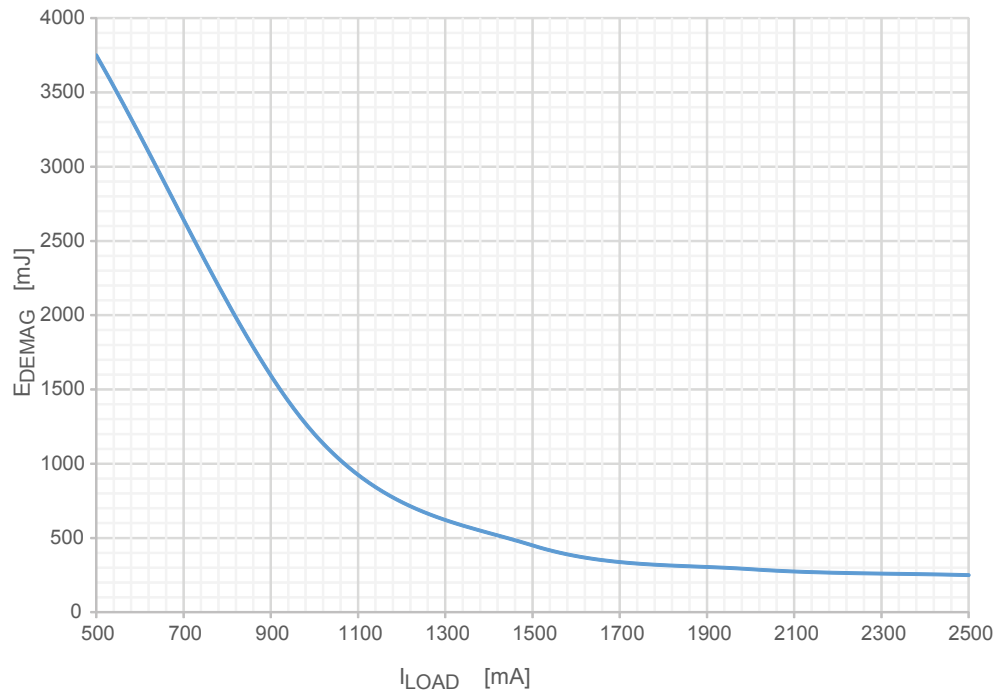

Figure 11. Fast demag waveforms



The demagnetization of inductive load causes large electrical and thermal stress on the IC. The plot below shows the maximum demagnetization energy that the IC can tolerate in a single demagnetization pulse with $V_{CC} = 24\text{ V}$ and $T_{AMB} = 125\text{ }^{\circ}\text{C}$. If higher demagnetization energy is required, then an external free-wheeling Schottky diode has to be connected between OUT (cathode) and GND (anode) pins. Note that in this case the fast demagnetization is inhibited.

Figure 12. Typical demagnetization energy (single pulse) at $V_{CC} = 24\text{ V}$ and $T_{AMB} = 125\text{ °C}$



8 Package information

In order to meet environmental requirements, ST offers these devices in different grades of **ECOPACK** packages, depending on their level of environmental compliance. ECOPACK specifications, grade definitions and product status are available at: www.st.com. ECOPACK is an ST trademark.

8.1 PowerSSO12 package information

Figure 13. PowerSSO12 package outline

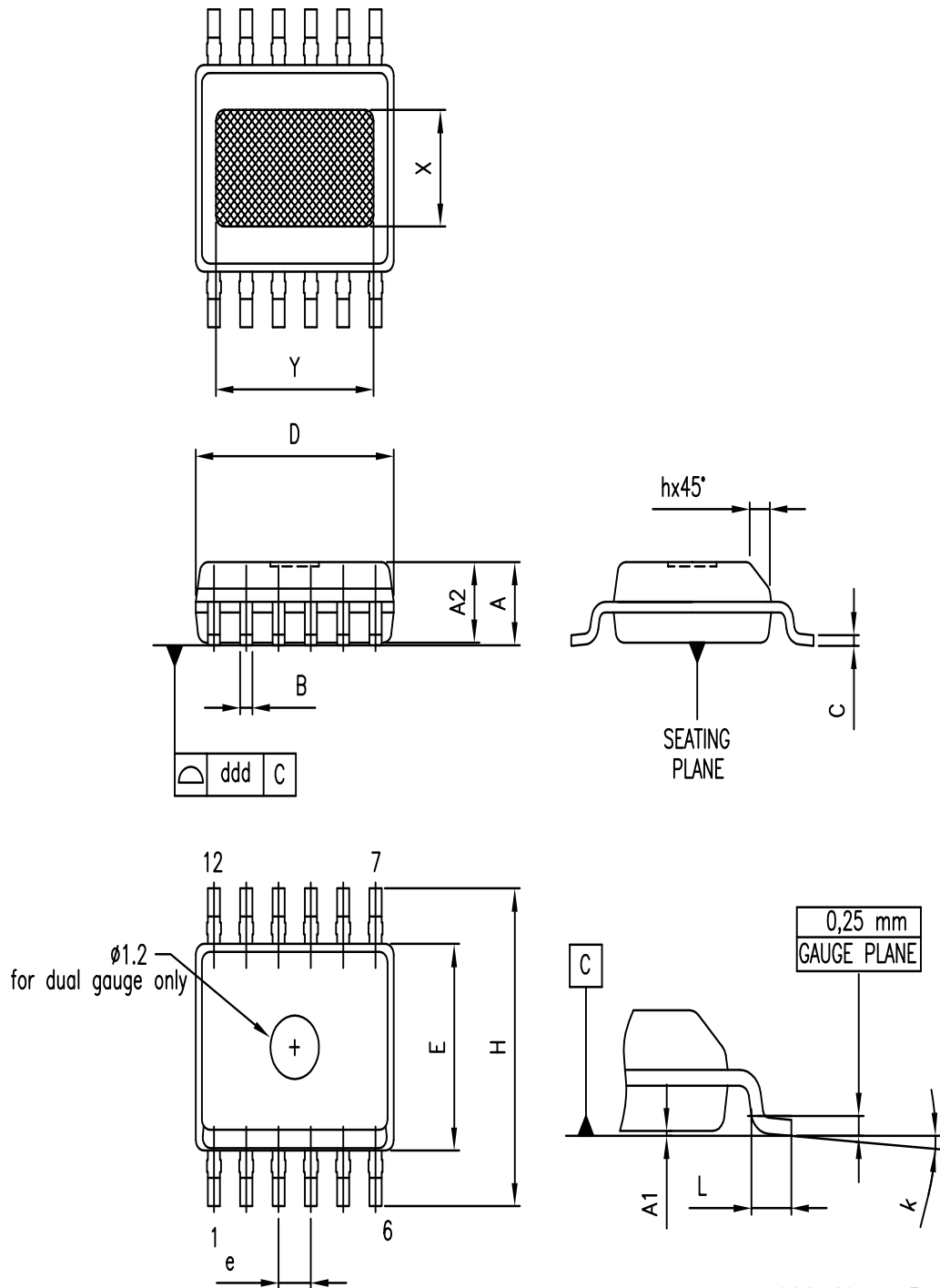

7392413 rev. D

Table 11. PowerSSO12 package mechanical data

Dim.	mm		
	Min.	Typ.	Max.
A	1.250		1.700
A1	0.000		0.100
A2	1.100		1.600
B	0.230		0.410
C	0.190		0.250
D	4.800		5.000
E	3.800		4.000
e		0.800	
H	5.800		6.200
h	0.250		0.55
L	0.400		1.270
k	0d		8d
X	1.900		2.500
Y	3.600		4.200
ddd			0.100

Note: Dimension D doesn't include mold flash protrusions or gate burrs. Mold flash protrusions or gate burrs don't exceed 0.15 mm in total both side.

Figure 14. PowerSSO12 recommended footprint

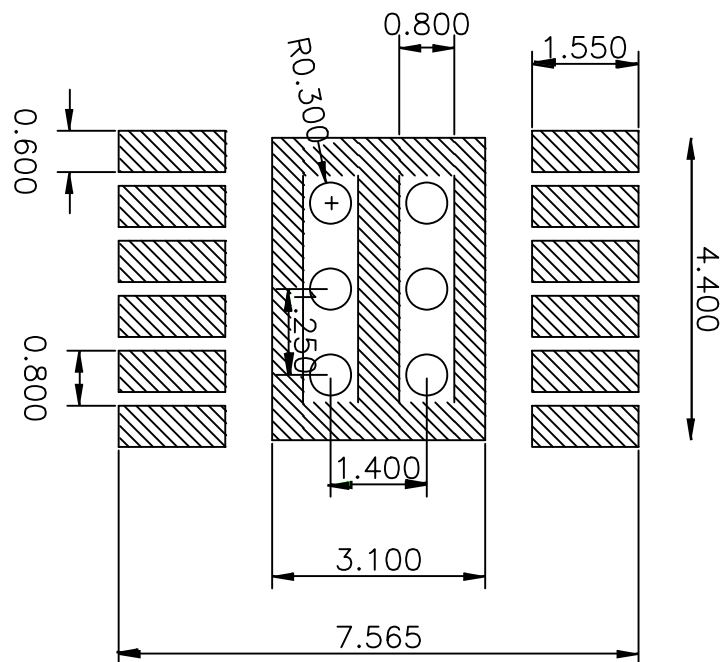

Figure 15. PowerSS012 tape packing information [mm]

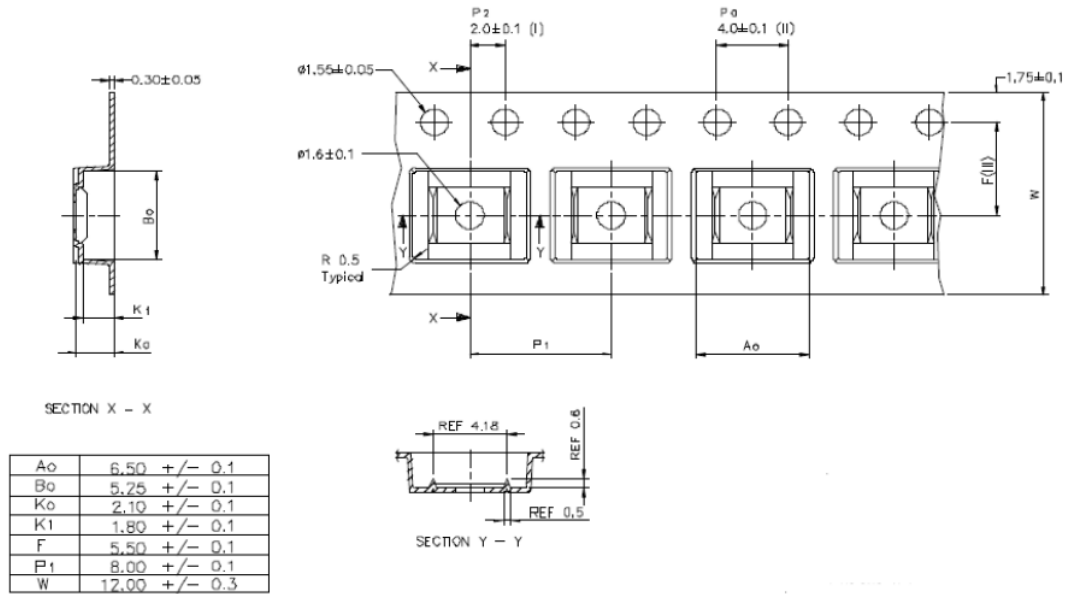
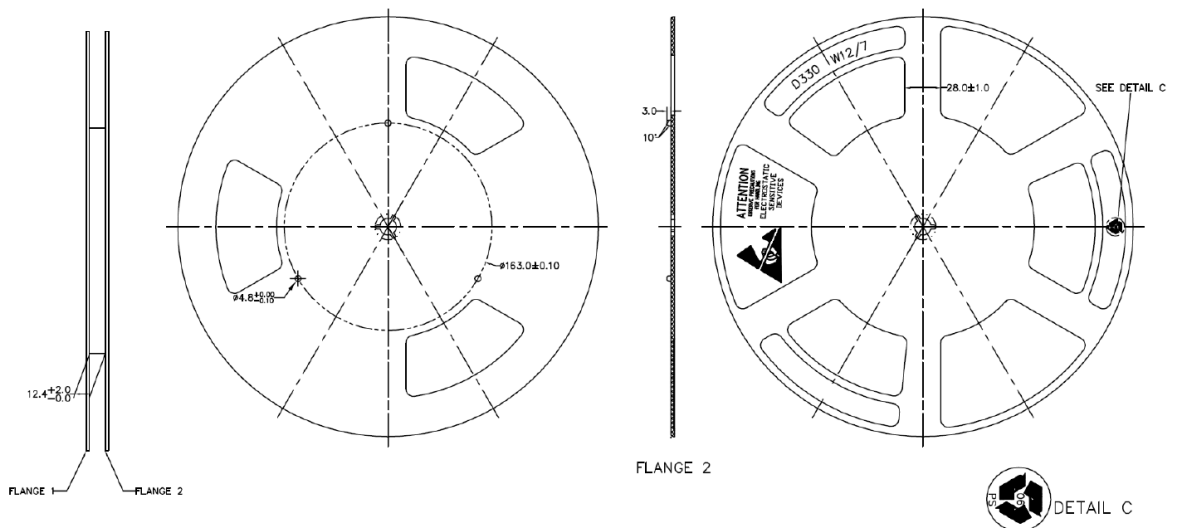

Figure 16. PowerSS012 reel packing information [mm]



- NOTES :
1. MATERIAL : POLYSTYRENE (BLACK)
 2. ANTISTATIC COATED
 3. FLANGE WARPAGE : 3 MM MAXIMUM
 4. ALL DIMENSIONS ARE IN MM
 5. ESD - SURFACE RESISTIVITY
- 10⁹ TO 10¹¹ OHMS/SQ.
 6. GENERAL TOLERANCE : ±0.25 MM
 7. TOTAL THICKNESS OF REEL: 18.4 MAX.
 8. MOLD NO: TX12-07-A3

Revision history

Table 12. Document revision history

Date	Revision	Changes
23-Apr-2020	1	Initial release.
26-Jun-2020	2	IPS161HF RPN added to document

Contents

1	Block diagram	2
2	Pin description	3
3	Absolute maximum ratings	5
4	Electrical characteristics	6
5	Output logic	10
6	Protection and diagnostic	11
6.1	Undervoltage lock-out	11
6.2	Overtemperature	11
6.3	Cut-off	11
6.4	Open load in off-state	13
6.5	VCC disconnection protection	14
6.6	GND disconnection protection	15
7	Active clamp	16
8	Package information	19
8.1	PowerSSO12 package information	20
	Revision history	23

List of tables

Table 1.	Pin configuration	3
Table 2.	Absolute maximum ratings	5
Table 3.	Thermal data	5
Table 4.	Supply	6
Table 5.	Output stage	6
Table 6.	Switching ($V_{CC} = 24\text{ V}$; $-40\text{ °C} < T_J < 125\text{ °C}$, $R_{LOAD} = 48\ \Omega$)	6
Table 7.	Logic inputs	8
Table 8.	Protection and diagnostic	9
Table 9.	Output stage truth table	10
Table 10.	Minimum cut-off delay for T_{AMB} less than -20 °C	12
Table 11.	PowerSSO12 package mechanical data	21
Table 12.	Document revision history	23

List of figures

Figure 1.	Block diagram	2
Figure 2.	Pin connection (top view)	3
Figure 3.	Reverse polarity	4
Figure 4.	Timing in normal operation	7
Figure 5.	Propagation delay at start-up	8
Figure 6.	Current limitation and cut-off.	12
Figure 7.	Open load off-state	13
Figure 8.	VCC disconnection	14
Figure 9.	GND disconnection	15
Figure 10.	Active clamp equivalent principle schematic	16
Figure 11.	Fast demag waveforms	17
Figure 12.	Typical demagnetization energy (single pulse) at $V_{CC} = 24\text{ V}$ and $T_{AMB} = 125\text{ °C}$	18
Figure 13.	PowerSSO12 package outline	20
Figure 14.	PowerSSO12 recommended footprint	21
Figure 15.	PowerSSO12 tape packing information [mm]	22
Figure 16.	PowerSSO12 reel packing information [mm]	22