

# AUTOMOTIVE PRODUCTS

For Innovative Analog Applications

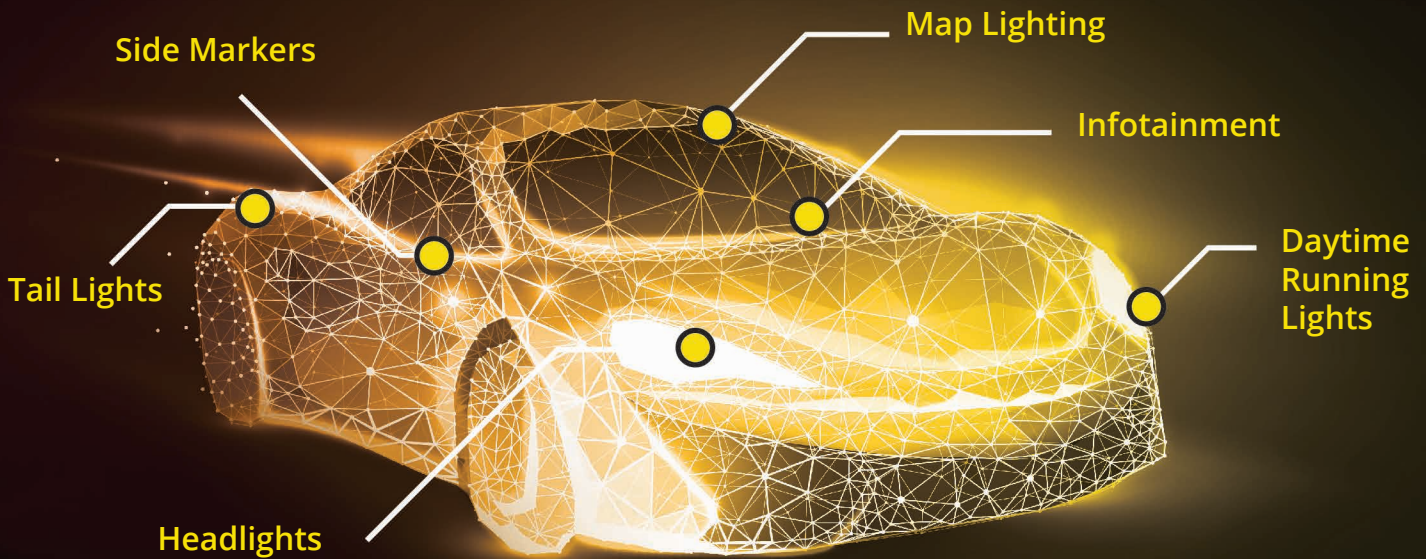

We also provide IC solutions for:



Motorcycles  
& Scooters



Semi Trucks



Construction &  
Farming Equipment



Autos & EV

Learn more at

**LUMISSIL.COM**



# TABLE OF CONTENTS

3	About Us	12	Exterior Automotive
4	Interior Automotive	13	Headlights, Fog Lights & DRL
5	Driver with Hall-Effect Sensor for Contactless Switching	14	High Voltage Asynchronous LED Driver
6	Dome/Map/Vanity/Glove/Trunk/Door-Puddle	15	LED Matrix Headlight
7	Ambient Lighting	16	RCL, CHMSL, Fog Lights & Animated Turn Lights
8	LIN RGB	17	ASIL Compliant Driver
9	Infotainment, Clusters, Audio & Backlight	19	6-Channel Linear Driver
10	48-channel Driver	20	Capacitance Touch Sensors Buttons, Sliders, Wheels & Proximity
11	24x4 Matrix Driver for Automotive LED Backlight & Information Display	21	Touch-Sense & Proximity Sensing
		22	MCUs
		23	MCUs: Automotive Control Sub-Systems
		24	Multi-Function I/O's: Automotive Network Control Sub-Systems
		25	Connectivity: G.vn Zonal Architecture In-Vehicle Networking (IVN)
		26	Connectivity: HomePlug Green PHY (HPGP)
		27	More information: Part Decoder & Lumissil Locations

## Automotive Application

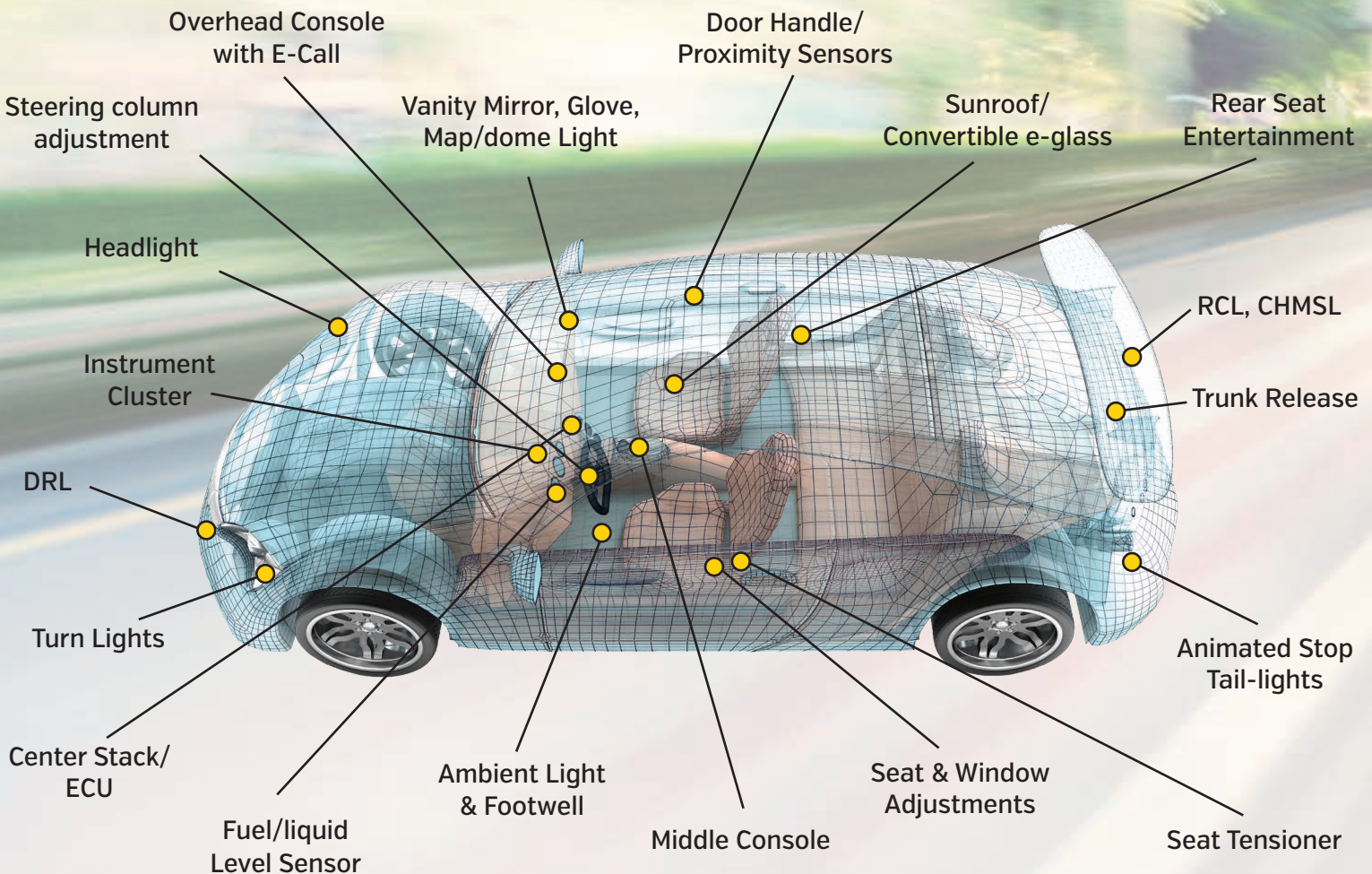



# ABOUT US

Lumissil Microsystems is a global supplier of mixed-signal IC technology designed to meet the needs of our broad range of customers in the automotive, industrial, appliance, and communication markets. Our primary products are feature-rich LED drivers, technology innovative vehicle networking transceivers, smart AI enabled video processors, microcontrollers and industry standard interface devices.

Lumissil is a division of ISSI which has more than a 20-year history as a major memory supplier to the automotive industry. Lumissil abides to ISSI's mission of long-term semiconductor support to the automotive market, even during periods of tight manufacturing capacity. Both Lumissil and ISSI are committed to providing excellent service, long-term support and latest technology to our valued automotive customers.

## Automotive Solutions Provider

Lumissil is continually growing its portfolio of innovative solutions which facilitate the design efforts of our customers. Our technology is used to illuminate cars, simplify inter-vehicle communication, help vehicles 'see' their environment and provide safety and comfort Human Machine Interfaces (HMI).

### Illumination

Our leading-edge LED drivers illuminate a car's interior and exterior to enhance brand recognition and increase safety. Our LED drivers cover a mix of linear and switching topologies with advanced noise and EMI reduction, thermal management and color management technologies.

### Communication

Our advanced In-Vehicle-Networking ICs using robust-OFDM communication technology over the power line have been adopted by car OEMs for intra-vehicle connectivity and inter-vehicle-to-charge station communication.

### Vision

Our deep-learning AI Video/Audio processors facilitate advanced edge processing capabilities for video and audio processing. These high-performance multi-core processors are used for in-cabin and exterior vehicle monitoring and consumer/industrial camera security applications.

## Control & Interface

Our family of microcontrollers with integrated flash memory are designed using 8051, ARM and RISC core processors for intelligent safety and comfort HMI applications. The portfolio includes advanced I/O devices with integrated LIN and CAN interfaces designed to meet the latest industry standards.

## Quality and Long-Term Support

All automotive products are qualified according to the Automotive Electronics Council (AEC) Reliability Test requirements (AEC-Q100). This includes both device and package testing. The latest generation automotive devices are designed to be compliant with ISO 26262 functional safety standards. Lumissil's automotive product development and manufacturing sites are ISO9001 and ISO/TS-16949 certified.

We are committed to long term product support and reliable product availability to ensure longevity of your designs.

## Samples Availability and Support

This selection guide provides an overview of Lumissil automotive products portfolio. Samples and evaluation boards for all products are available to qualified customers. Please contact your sales representative or distributor for your free sample needs.

### Contact Us

Headquarters  
1623 Buckeye Dr.  
Milpitas, California 95035

### Phone number

408-969-6600

### Website

[www.lumissil.com](http://www.lumissil.com)

### Request for more information

[www.lumissil.com/contact](http://www.lumissil.com/contact)

# INTERIOR AUTOMOTIVE

A car's interior "comfort rating" is an important differentiating factor since increasingly car buyers value comfort over engine power. It is up to car OEMs to develop intelligent controls complemented with lighting to make for a pleasant cabin experience. Today's cars and evolving autonomous vehicles rely on microcontrollers and LED lighting to enhance the driver/passenger experience and safety. For example, the instrument cluster located behind the steering wheel houses a variety of gauges and indicators to display the vehicle's status. At a glance, it provides vehicle driving information such as gasoline or charge level, speed, travel distance, and hazard alerts. In combination with visual alerts, haptic technology such as steering wheel

and seat vibrations serve to augment a driver's awareness. In combination, color lighting and vibration serve as "gentle" attention grabbing notifications.

Lumissil offers a broad portfolio of silicon solutions to increase a vehicle's cabin comfort level. Our LED drivers for interior accent lighting and instrument cluster applications provide an appealing interior experience. Our microcontrollers for touch sensing and mechanical control enhance the HMI (Human Machine Interface) experience. Lumissil's automotive IC solutions are AEC-Q100 qualified, meaning they have passed the specified stress tests to guarantee automotive quality and reliability.

## Interior lighting applications:

- Instrument cluster
- Infotainment and multimedia display
- Glove box and vanity mirror lighting
- Overhead cabin lighting
- Color accent lighting in doors, seating, dashboard/console

## Microcontroller applications:

- Microcontroller applications
- Instrument cluster gauges
- Overhead/middle console
- Steering wheel and seat adjustment
- Touch sensors

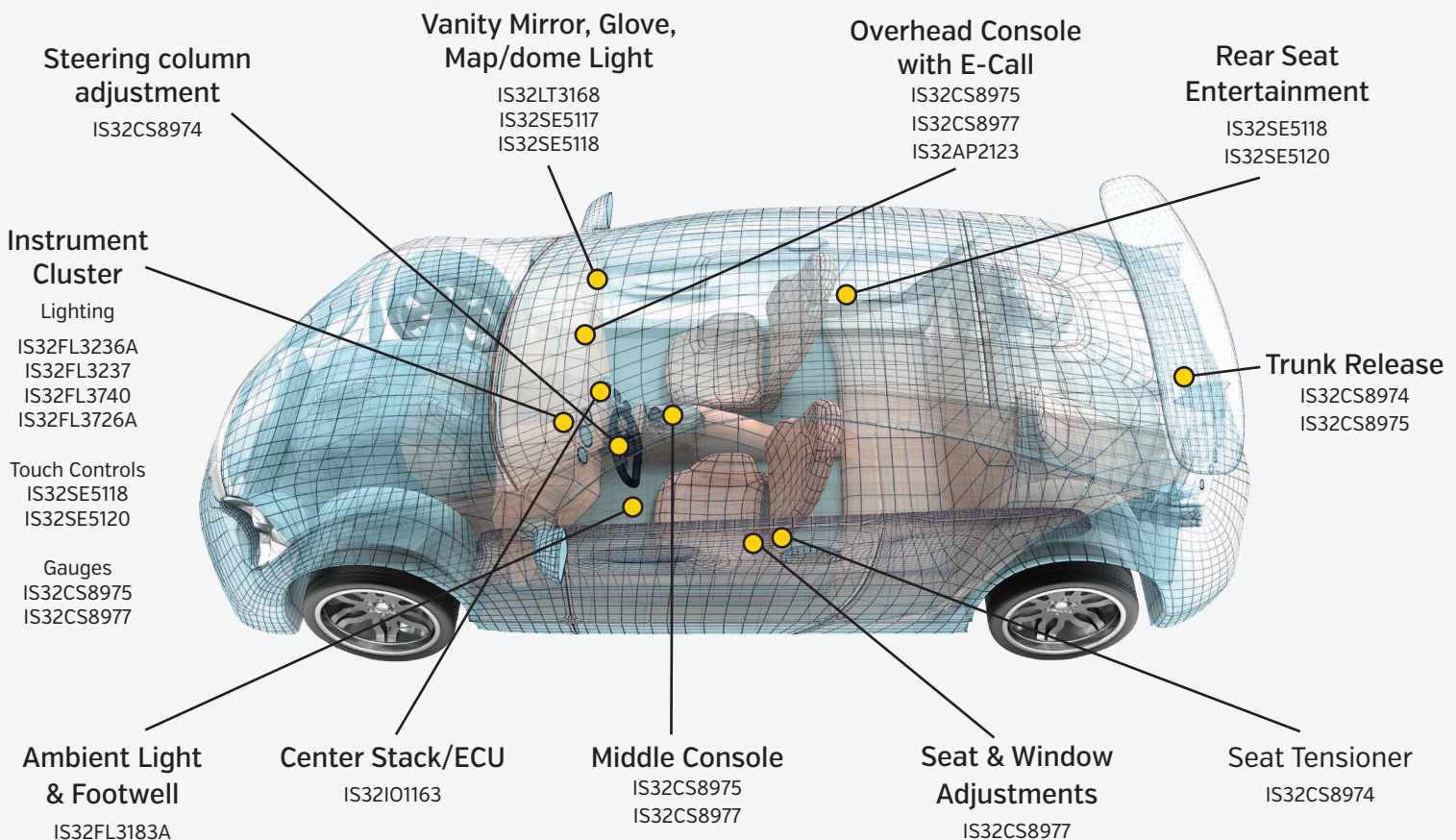



### LED Driver with Hall-Effect Sensor for Contactless Switching

- 6.5V to 28V supply (capable to withstand 40V load dump)
- Ultra-low standby current (50uA)
- Integrated Omnipolar Hall-effect sensor for contactless switching
  - Works with North/South pole magnet to trigger LED driver or other on-board circuitry
- Single channel current source configurable from 20mA to 200mA
- LED dimming with Gamma-corrected fading or external PWM
- SOP-8-EP, -40°C ~ +125°C, AEC-Q100

### List of Key Advantages:

- Integrated Hall-Effect sensor for contactless control
- Small package
- No host processor or software required

### Application

A magnet on any open/close cover eliminates the need for a mechanical switch for turning on/off an illumination LED. Typical applications are the door/latch for glove compartments, visor vanity mirrors, trunk and door-puddle lighting. The standalone LED driver can be enabled by its proximity to a local magnet for contactless operation replacing the need for a conventional mechanical switch.

Part Number	# CH	Current	Switch	Supply	Pkg
-------------	------	---------	--------	--------	-----

IS32LT3168	1	1-CH: 20mA to 200mA	Hall or mechanical	6.5 to 28V	SOP-8-EP
------------	---	---------------------------	-----------------------	---------------	----------

### Applications Diagram

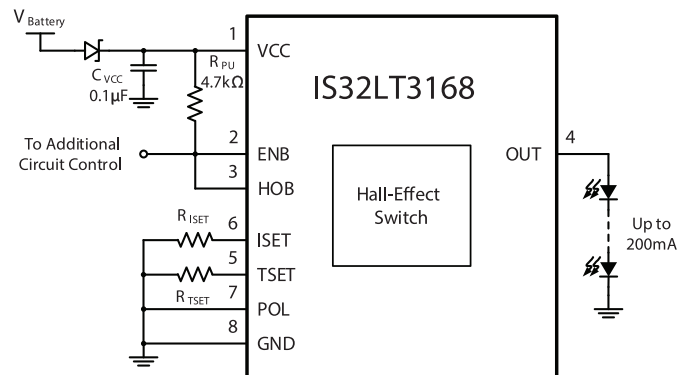

Glove Compartment



Puddle Light



Trunk Light



Vanity Light

### Automotive Interior LED Linear Drivers

- Single or triple channel configurable current source
- PWM or automatic Gamma-corrected luminosity fading
- Momentary/latched/Magnetic switch control
- Fault Protection
- Small package, -40°C to +125°C, AEC-Q100

### Description

LED drivers with integrated gamma-corrected fade ON/OFF provide smooth lighting transitions for Interior automotive lighting applications. Lumissil's single or triple channel LED drivers come with a momentary (internally debounced), latched or a magnetic switch option. For example a central map/dome light application benefits from a triple channel driver (two for bright LEDs and one for button switch backlighting) while a glove compartment application can use a single channel driver.

### Application

- Dome
- Map
- Glove box
- Vanity mirror
- Trunk light
- Door-Puddle

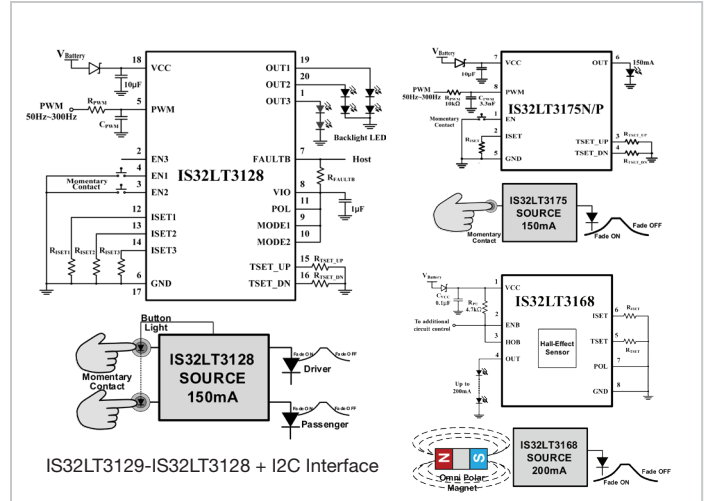

Part Number	# of Channels	Current	Switch	Supply	Pkg
IS32LT3128	3	2-CH: 20mA to 150mA, 1-CH: 30mA	Momentary or latched	5V to 42V	eTSSOP-20
IS32LT3128A	3	2-CH: 20mA to 150mA, 1-CH: 30mA	Momentary or latched	5V to 42V	eTSSOP-20
IS32LT3129	3	2-CH: 20mA to 150mA, 1-CH: 30mA	Momentary or latched	5V to 42V	eTSSOP-20
IS32LT3129A	3	2-CH: 20mA to 150mA, 1-CH: 30mA	Momentary or latched	5V to 42V	eTSSOP-20
IS32LT3168	1	20mA to 200mA	Hall-Effect Sensor	6.5V to 28V; maximum 36V	SOP-8-EP
IS32LT3175N	1	YES (Positive)	Fault protect, SOP-8 package	150	SOP-8-EP
IS32LT3175P	1	YES (Positive)	Fault protect, SOP-8 package	150	SOP-8-EP

### Interior Cabin Linear Driver

- Operating voltage
  - High Brightness: 5V to 42V
  - RGB : 2.7V to 5.5V
- High Brightness Driver
  - Integrated fault detection and reporting
    - LED Open/Short
    - Over temperature with thermal rollback
  - Flexible LED dimming
    - PSM (Power Supply Modulation)
    - PWM (Pulse Width Modulation)
- RGB Driver
  - I2C Bus Configurable
    - High frequency 16-bit PWM color mixing
    - Individual LED addressable and programmable
    - Integrated EMI reduction technology
    - Spread spectrum
    - Staggered outputs and noise canceling channels
- -40°C ~ +125°C; AEC-Q100



Cabin Lighting

### Ordering Information

Part Number	# CH	Current	Type	Pkg
IS32FL3209	18/6 RGB	78mA	RGB	WFQFN-28
IS32FL3237	36/12 RGB	38mA	RGB	eTQFP48
IS32FL3238	18/6 RGB	78mA	RGB	eTSSOP-28
IS32FL3738	6x8 Matrix-48	84mA	RGB	eTSSOP-28
IS32FL3740	3x4 Matrix-12	84mA	RGB	eTSSOP-20
IS32LT3126	2	150mA	WHITE	eTSSOP-16
IS32LT3177	1	200mA	WHITE	SOT23-6, SOP-8-EP
IS32LT3178	1	200mA	WHITE	SOT23-6, SOP-8-EP
IS32LT3183A	4/RGB+W	60mA	RGB/W	SOP-8-EP

### Description

Automotive ambient lighting provides attractive and functional interior illumination to enhance the occupant's comfort and well being. Lumissil's ambient LED driver portfolio support up to 16-bit PWM resolution for creating spectacular and accurate colors. Innovative noise cancellation technologies such as spread spectrum, phase delay drastically reduces electromagnetic emissions. Low shutdown current minimizes energy consumption while fault reporting capabilities make these devices ideal for reliable operation.

### Application

- Ambient Lighting
- Footwell
- Puddle lamp
- Cluster telltale
- Indicators
- Knob/button backlight





## IS32LT3183A: Ambient Light Solution

- Operating voltage: 5.5V to 18V [40V tolerate]
- 4 channels of current sinks of up to 60mA
  - Reconfigurable to GPIO, SPI/I2C
  - High Color resolution of up to 16-Bit LED color range with LED temperature compensation
- Dimming and color transition function with programmable transition time
- LIN 2.0/2.1/2.2A and SAE J2602 compliant LIN control interface
- Integrated MCU for LIN protocol handling and LIN message decoding
- Protection:
  - Open/Short LED detection
  - High temperature warning and shutdown
- SOP-8EP package with temp range -40°C ~ +150°C

## Key Advantages

- Precise color calibration and selection
- Small module controlled by 1-wire LIN bus

## Application

- Vehicle ambient Lighting
- Dome LED Lighting
- LIN to SPI or LIN to I2C bridging
- General Purpose MCU for LIN slave node operation

## Ordering Information

Part Number	Package	QTY/Reel
IS32LT3183A-GRLA3-TR	SOP-8-EP, Lead-free	2500

## Application Diagram

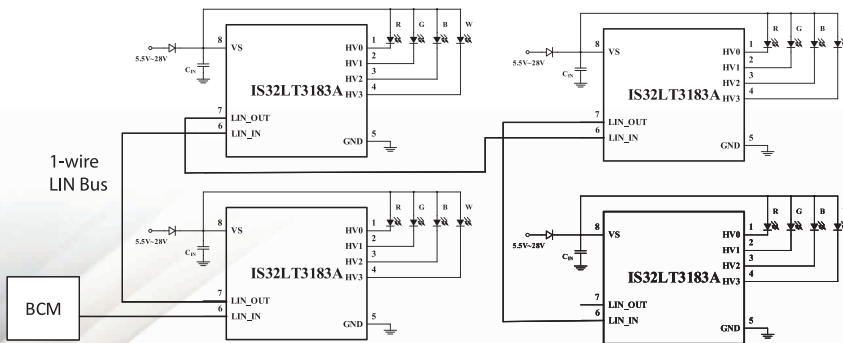



# INFOTAINMENT, CLUSTERS, AUDIO & BACKLIGHT

## Infotainment & Clusters

### Audio:

- 5-24V Supply
- Mono BTL Class-D
- 22W/CH into 4Ω Speaker
- Selectable Gain Settings

### Matrix LED Driver:

- 2.7-5.5V Supply
- Matrix or Multi-channel architecture
- Individual LED Control
- 1MHz I2C Host Control

### MCU and Sensor

- 8-bit single cycle 8051
- 16 Channel programmable capacitive touch

### All Devices:

- Fault Reporting
- -40°C to +125°C, AEC-Q100

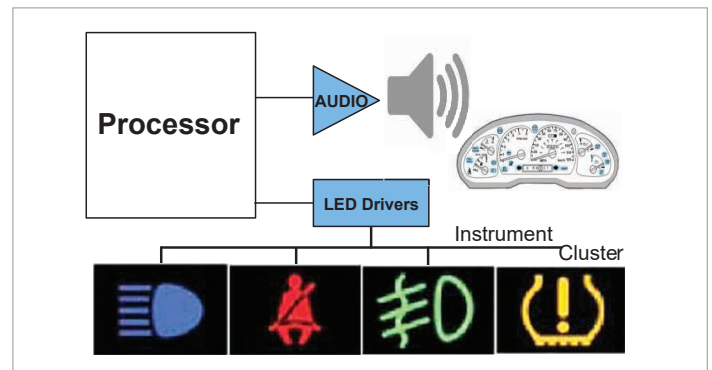

## Description

Infotainment Systems and Instrument Clusters are transforming the driver and passenger experience inside the car, impacting a customer's buying decision. Infotainment systems are getting more sophisticated and clusters are displaying more information than ever before.

The audible chime is one part of an automotive cluster; it provides audio feedback during turn signal-flasher operation, seat belt warning, etc. Visual feedback to alert when something is wrong is in the form of LED backlight of various cluster warning lights or icons.

Modern infotainment systems and controls benefit from an intuitive driver-car interface. LED backlighting of control switches make them easily identifiable, day or night. Adding a capacitive touch feature not only enhances functionality but also adds to the car's perceived elegance and value.

## Application

- Chime Alerts (Audio and Visual)
- Adjustable Backlight Icons and Buttons

## Infotainment and Instrument Cluster Devices

Family	Device	Features	Package
Audio	IS32AP2123	22W Mono Class-D	eTSSOP-16
FxLED	IS32FL3209	18-Channel @ 76mA	WFQFN-28 eTSSOP-28
FxLED	IS32FL3738	6x8 Matrix LEDs	eTSSOP-28
FxLED	IS32FL3238	18-Channel @ 76mA, Noise reduction	WFQFN-28 eTSSOP-28
FxLED	IS32FL3738	6x8 Matrix LEDs	eTSSOP-28
Sensor	IS32SE5110	16-CH Programmable Capacitive Touch	TSSOP-24
Sensor	IS32SE5117/SE5118/SE5120	Programmable Capacitive Touch and proximity sensors	QFN-16, QFN-24, QFN-32
MCU SHIFT	IS32CS8975/8975/8977 km/h	8-bit single cycle 8051 with 32kB flash, 1kB RAM, 16-Channel 12-bit ADC	TSSOP-24, TSSOP-20, TSSOP-16, SOP-8

## IS32FL3248 Features

- Vcc supply: 3.0 to 5.5V
- VLED: 4.5V to 16V (18V tolerant), multiple LED in series possible
- 33MHz VSB Host Control
- 48-channels of current sinks
  - 33mA@VCC=5V/channel maximum
  - 23mA@VCC=3V/channel maximum
- Maximum Current Band [CB]
  - 3-bits [8 steps] with a 9.7% to 100%
- DC Current Scaling [SL]
  - 6-bits [64 steps] with a 25.9% to 100% range
- Individual 16-bits, 8+8-bits dithering, 8+4-bits dithering, 8-bits PWM mode
- Global Current Control [GCC]
  - 8-bits [256 steps] with a 9.6% to 100% range
  - 3 GCC sets for each color group
- Constant Current Accuracy
  - Channel to Channel =  $\pm 2\%$ [typ.],  $\pm 5\%$ [max.]
  - Device to Device =  $\pm 2\%$ [typ.],  $\pm 5\%$ [max.]
- Selectable Traditional PWM and ES-PWM [dithering]
- Real-time LED Open/Short Detection
- Over temperature protection
- Spread Spectrums
- 180-degree phase delay operation to reduce power noise
  - $-40^{\circ}\text{C}$  to  $+125^{\circ}\text{C}$ , AEC-Q100
- eLQFP-64 (10mm $\times$ 10mm) and WFQFN-64 (9mm $\times$ 9mm) packages

## Application

- Automotive LED Back Light
- Automotive Center Information Display
- Automotive Signage

## Key Advantages

- 48-channels of current sinks
- High current accuracy
- Traditional PWM and ES-PWM [dithering]
- Fault detection and noise mitigation

## Applications Diagram

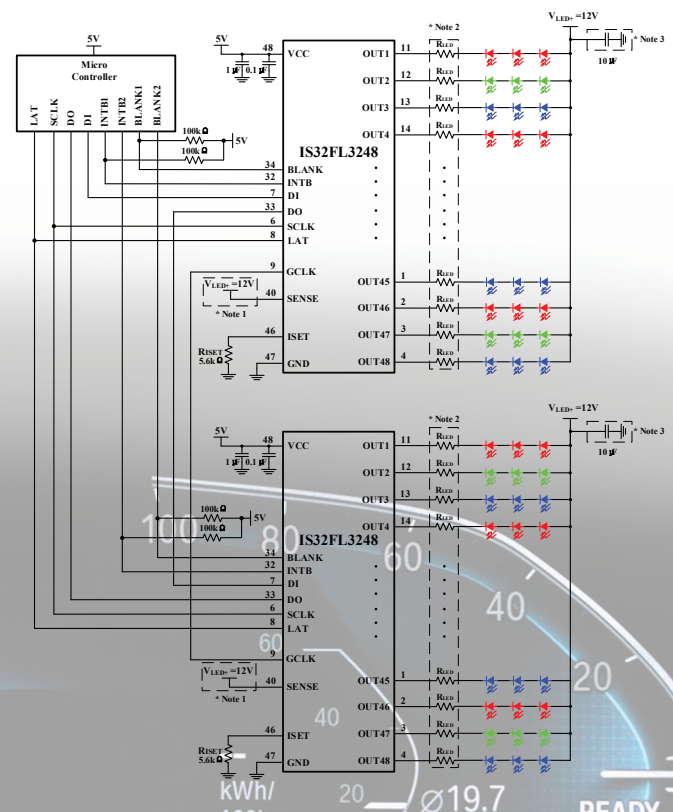

## Ordering Information

Part Number	Package	Quantity
IS32FL3248-LQLA3-TR	eLQFP-64, Lead-free	2500
IS32FL3248-QWLA3-TR	WFQFN-64, Lead-free	2500

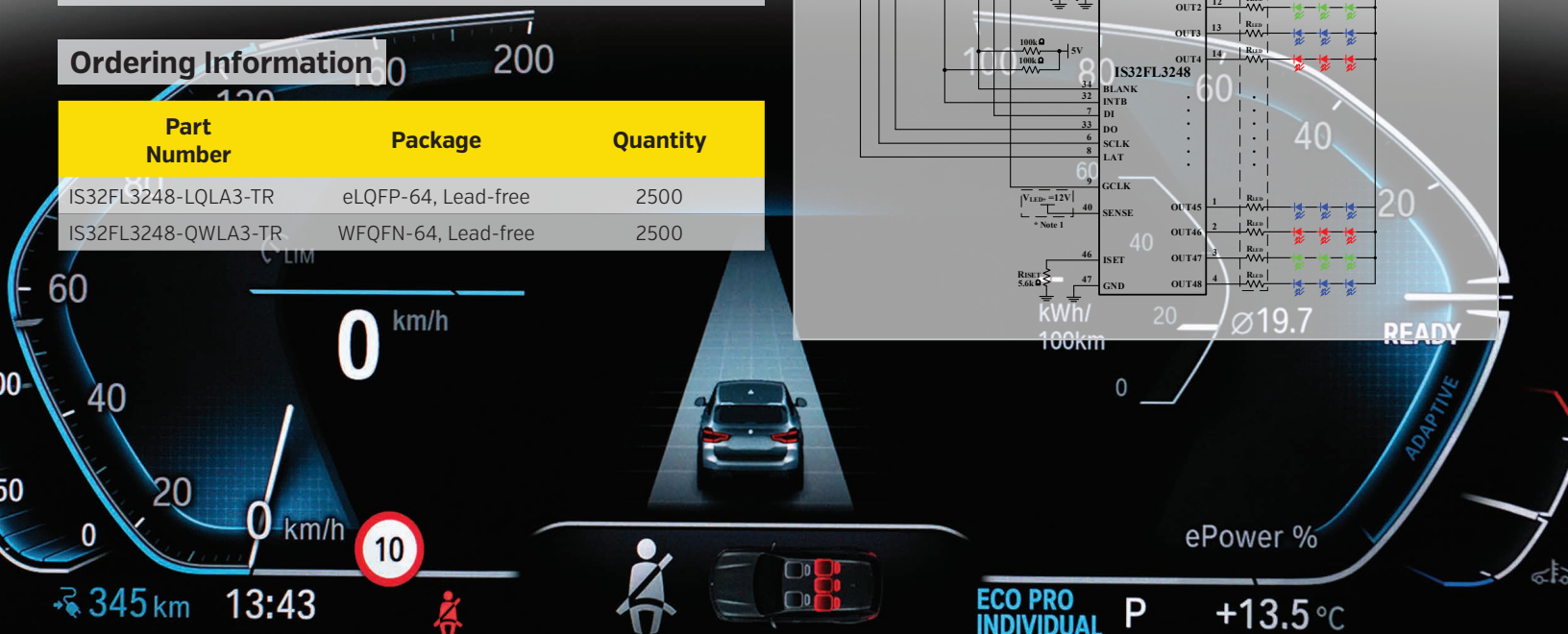



## IS32FL3749 Features

- 4.5V to 16V [20V tolerant]; multiple LED in series possible
- Low standby and sleep mode current
- Support 24 constant current channels of 60mA/ch with 4 power scans
- Host Interfaces: VSB (video serial bus, 33MHz), SPI [33MHz]
- LED Control:
  - 8-bits or 16-bits or 8+4-bits dithering or 8+8-bits dithering PWM
  - 8-bits dot correction
  - 8-bits × 3 global current adjustment
  - De-ghosting at reduced reverse bias to improve LED reliability
- Noise reduction:
  - Channel-to-channel timing skew to reduce transient noise
  - 4 groups delay to minimize the power ripple
  - Spread spectrum to optimize EMI
- Protections:
  - Power scan [PSW] short protection
  - LED open/short detection with location registers
  - Over temperature protection
  - Overvoltage protection
- - 40°C to 125°C, AEC-Q100, eTQFP-48 [7mmx7mm]

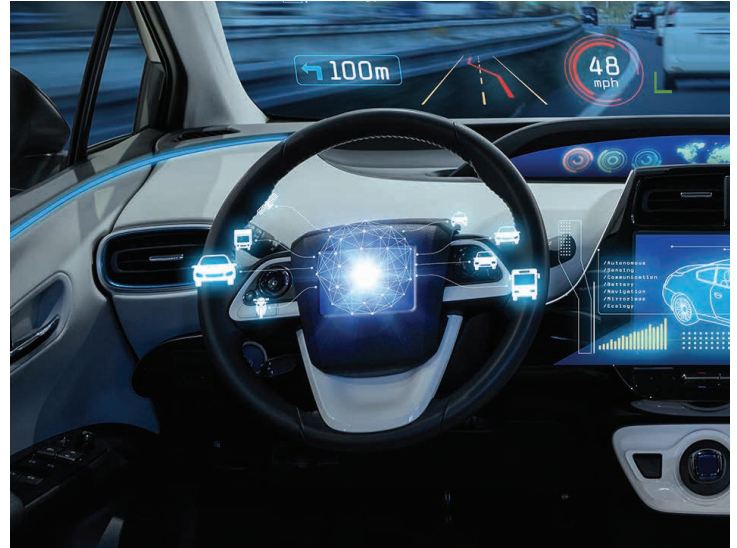

## Applications Diagram

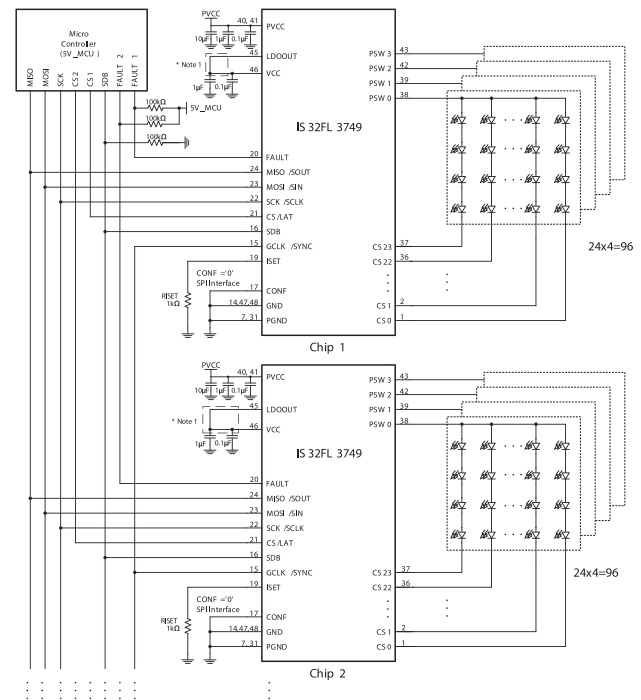

## Application

- Automotive LED Back Light
- Automotive Center Information Display
- Automotive Cluster Display

## Key Advantages

- High-voltage 24x4 LED matrix support
- Rich color with high resolution brightness LED control
- Low noise and robust fault detection

## Ordering Information

Part Number	Package	Quantity
IS32FL3749-TQLA3-TR	eTQFP-48, Lead-free	2500

# EXTERIOR AUTOMOTIVE

Automotive exterior refers to all the lights and controls around the outer perimeter of a vehicle, whether it is a car, motorcycle, bus, or truck. Exterior lighting provides a competitive differentiation to enhance a vehicle's perceived value and brand recognition. Well-positioned and contoured lighting helps the vehicle stand out while providing informative signaling and illumination functions. While microcontrollers are unseen, they are necessary for door handle sensing, moon roof control, and even performing taillight animations.

Lumissil provides AEC-Q100 LED drivers and microcontrollers for advanced automotive applications. These intelligent LED controllers take car safety to the next level by enabling dynamic signaling on rear combination lights, dual intensity for daytime running lights, synchronized welcome lights and glare free headlights.

## ■ Informative signaling:

- Rear Combination Light (RCL)
- Center High-Mounted Stop Light (CHMSL)
- Daytime Running Light (DRL)
- Turn/Emergency Lights
- Welcome Light

## ■ Illumination:

- Head Light
- Fog Lamp
- Reverse Light
- License Plate

## ■ Microcontroller:

- Touch and proximity sensing
- Sunroof & trunk control

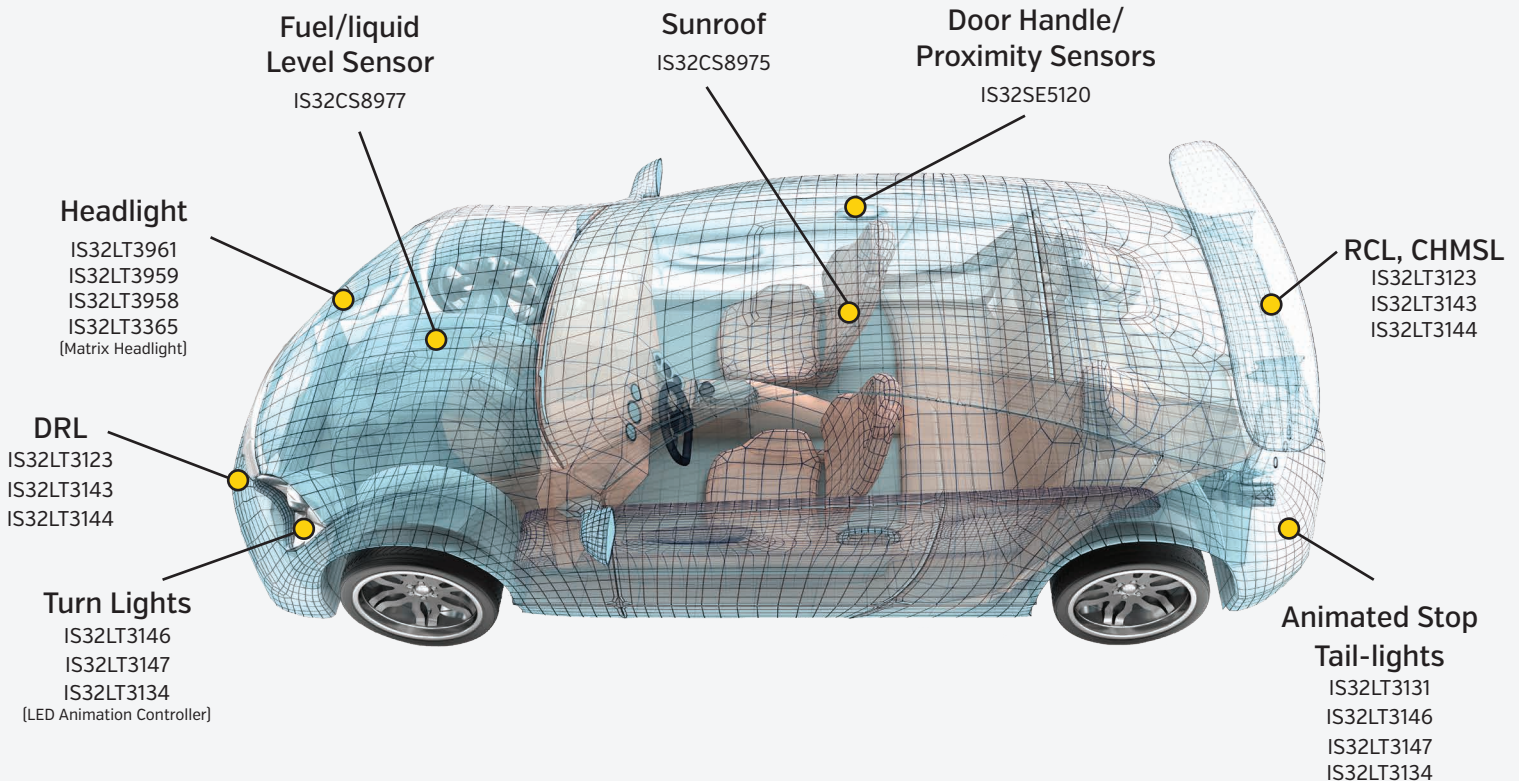



## Description

New vehicles utilize LED headlights due to their efficiency, durability, reliability and refined luminosity control. Basic headlights provide two levels of luminosity control. Advanced headlights systems such as matrix headlight enables refined dimming control of an array of LEDs; such that other in-front vehicles can be glare-free and also made more visible to the driver. Switching LED drivers provides high current at high efficiency.

## Application

- Headlights
- Matrix Headlights
- Daytime Running Lights [DRL]
- Fog Lights

## Linear & Switching LED Drivers

### Linear Drivers:

- 2 to 3 channel
- External PWM, Internal PWM or Analog dimming
- ADC for LED binning or temperature sensing of LEDs
- Fault Protection and Reporting
- -40°C to +150°C, AEC-Q100

### Switching Drivers:

- Buck or Boost or Buck-boost or SEPIC switching drivers
- Analog or PWM Dimming
- ADC for LED binning or temperature sensing of LEDs
- Fault Protection and Reporting
- -40°C to +125°C or +150°C, AEC-Q100

## Applications Diagram

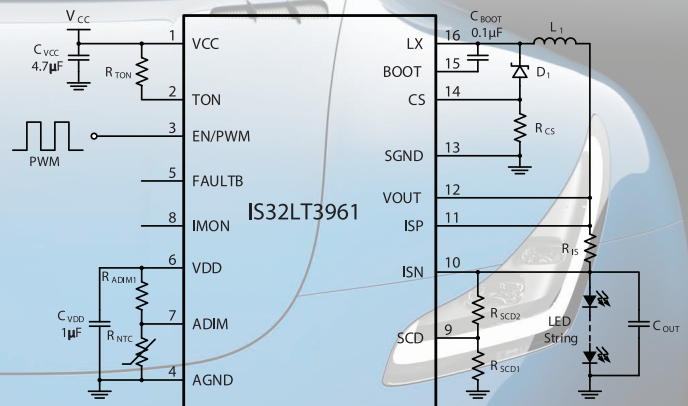

## Ordering Information

Part Number	#CH	Type	Current	LED Dimming	Fault	Package
IS32LT3951	1	Buck	1.5A	PWM	Faults protection and Report	SOP-8-EP
IS32LT3952	1	Buck	1.5A	PWM	Faults protection only	SOP-8-EP
IS32LT3953	1	Buck	3A	PWM	Faults protection only	SOP-8-EP
IS32LT3954	1	Buck	3A	PWM	Faults protection and Report	SOP-8-EP
IS32LT3123	2	Linear	External FET	External PWM, Internal PWM,	Faults protection and Report	eTSSOP-24
IS32LT3957A	1	Buck,boost, Buck-boost, SEPIC	External FET	PWM, Analog	Faults protection and Report	eTSSOP-16
IS32LT3958	1	Buck, Boost, Buck-boost, SEPIC	External FET	External PWM, internal PWM, Analog	Faults protection and Report	eTSSOP-20
IS32LT3959	1	Buck, Boost, Buck-boost	External FET	External PWM, internal PWM, Analog	Faults protection and Report	eTSSOP-28
IS32LT3961	1	Buck	2A	PWM, Analog, Bypass MOS-FET shunt	Faults protection and Report	eTSSOP-16
IS32LT3365	12	Large array dimmer	1.5A	PWM	Faults protection and Report, ISO26262	eLQFP-48

### IS32LT3959 Features

- Wide input voltage: 4.5V to 55V
- 1.5 $\mu$ A shutdown supply current
- Integrated bootstrap diode
- Buck, Boost and Buck-boost topologies
- Additional output current regulator to prevent rush current
- $\pm 3\%$  output current accuracy
- Integrated PWM generator
- Flexible dimming: analog, external PWM or internal PWM
- Integrated PMOS driver to enable PWM dimming
- Spread spectrum for EMI profile optimization
- External clock synchronization capability
- Internal fixed soft start to avoid inrush current
- Robust protections with fault reporting: Overvoltage protection, LED string open/shorted, Output over-current, Input over-current, FS/SYNC pin open/shorted, FPWM pin open/shorted, Thermal shutdown
- AEC-Q100, -40°C ~ +150°C

### Application

- Headlight
- Daytime Running Lamp (DRL)
- Fog Lamp
- Turn signal light

### Key Advantages

- Buck, Boost and Buck-boost topologies
- Flexible dimming: analog, external PWM or internal PWM
- Integrated PMOS driver to enable PWM dimming

### Ordering Information

Part Number	Package	Quantity
IS32LT3959-ZLA3-TR	eTSSOP-28, Lead-free	2500

### Applications Diagram

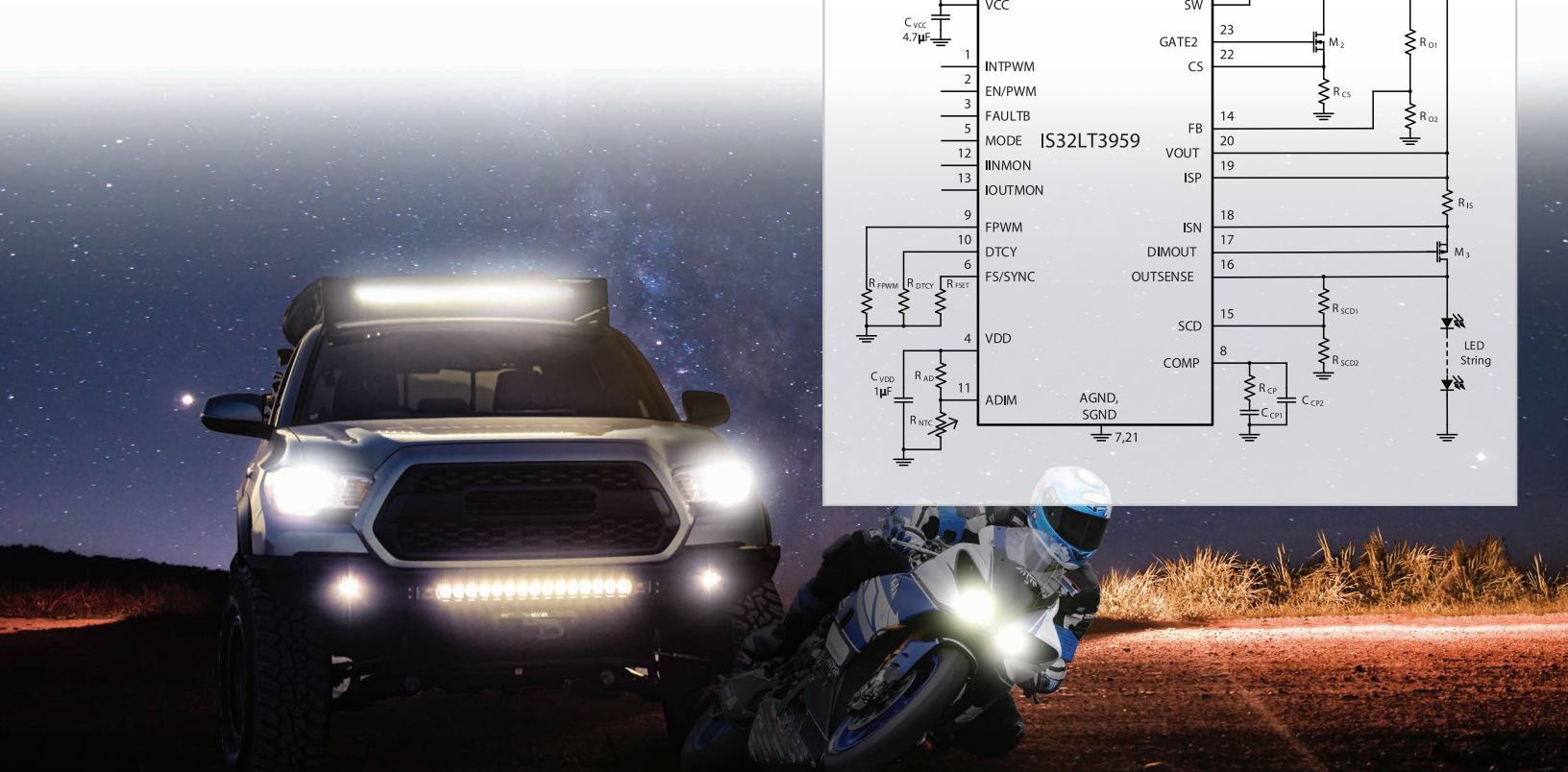
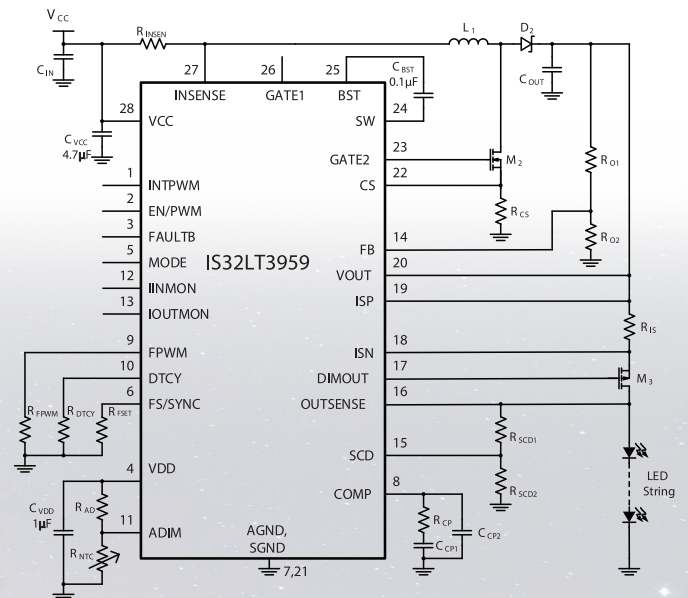



## IS32LT3365 & IS32LT3961 Features

### IS32LT3365 (LED array dimmer):

- 3 PN's with CANLITE, UART, or SPI Host Interfaces
- Wide input supply: 4.5V to 58V
- Integrated 12 Series LED Bypass Switches in 4 groups
- 10-bits PWM dimming resolution
- Adjustable PWM frequency with multiple device synch
- I2C EEPROM interface for LED binning and calibration
- Two 10-bits ADC for temperature sensing (via thermistor) of PCB and LEDs
- EMI optimization: Phase shift, Spread Spectrum, Slew rate control
- ASIL compliant Fault protection and report: LED open/short, Single LED short, Thermal Alarm
- eLQFP-48, -40°C to +150°C, AEC-Q100

### IS32LT3961 (current source):

- Wide input supply: 5V to 60V
- Low power shutdown (typical 1uA)
- 2A max output current over operating temperature
- Output current monitor
- PWM dimming capability
- Analog dimming for LED binning or thermal roll-off protection
- Spread spectrum to optimize EMI
- Robust fault protection and reporting
- eTSSOP-16, -40°C to +150°C, AEC-Q100



## Applications Diagram

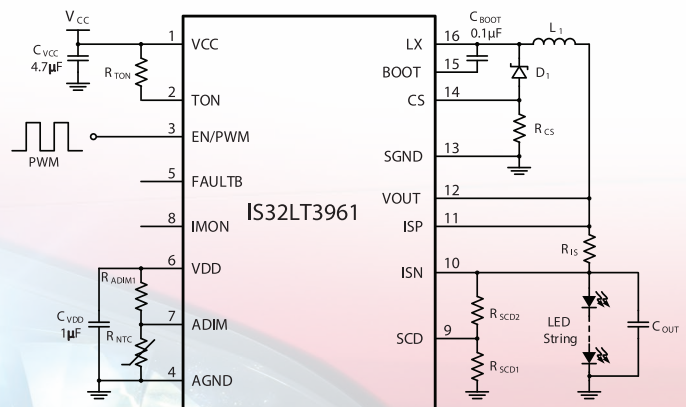
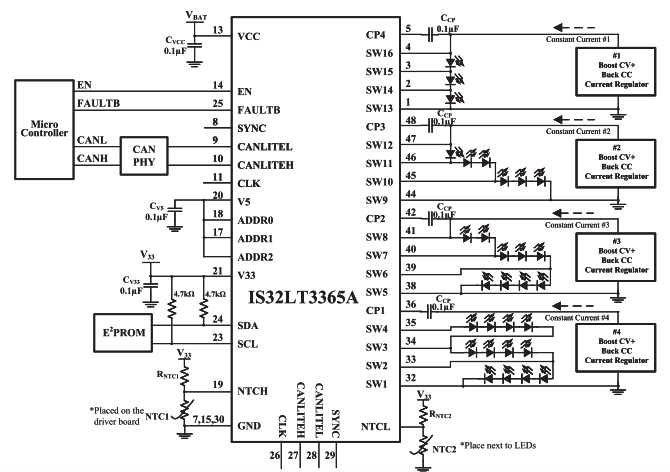

## Application

- LED Matrix Headlight

## Key Advantages

- High integration for compact size
- Fault detection and protection for high reliability
- High resolution dimming
- Multiple EMI optimization mechanisms built-in
- ASIL compliance

## Ordering Information

Part Number	Host Interface	Package
IS32LT3365A-LQLA4-TR	CANLITE	eLQFP-48, Lead-free
IS32LT3365B-LQLA4-TR	UART	eLQFP-48, Lead-free
IS32LT3365C-LQLA4-TR	SPI	eLQFP-48, Lead-free
IS32LT3961-ZLA3-TR	None	eTSSOP-16, Lead-free

### Description

Rear vehicle lights are important for a vehicle's safety. Stop and turn signal lights are required to notify the rear vehicle of the driver's intentions. Reverse and fog lights are high luminous output to provide visibility during night or fog driving conditions.

### Features

#### Linear Drivers:

- 2, 3, 6 or 12 channels
- External PWM, Internal PWM or Analog dimming
- ADC for LED binning or temperature sensing of LEDs
- Fault Protection and Reporting
- -40°C to +150°C, AEC-Q100

#### LED Animation Controller:

- Up to 12 channels
- 0.1s to 15s animation duration
- Four pattern banks with 12KB Flash each
- Animation across cascade connected controllers
- Support programmable duty cycle for dimming
- -40°C to +125°C, AEC-Q100

### Applications

- Stop Tail-lights & CHMSL
- Rear Combination Lights (RCL)
- Reverse & Fog Lights
- Sequential Turn Signals

### Applications Diagram

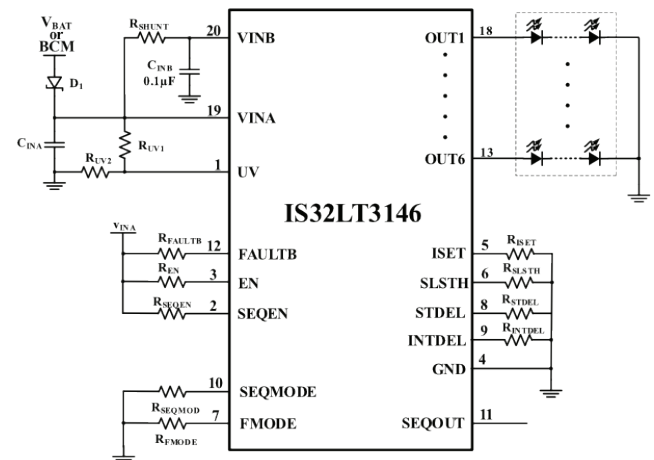

### Ordering Information

Part Number	#CH	Type	Current/CH (mA)	LED Dimming	Fault Protect & Report	Package
IS32LT3123	2	Linear	External FET	External PWM, Internal PWM	YES	eTSSOP-24
IS32LT3124	4	Linear	150	PWM & BCM	YES	eTSSOP-16
IS32LT3126	2	Linear	150	PWM & BCM	YES	eTSSOP-16
IS32LT3143	3	Linear	150	PWM	YES	eTSSOP-16
IS32LT3144	3	Linear	150	PWM, Analog	YES	eTSSOP-16
IS32LT3146	6	Linear	75	State Machine	YES	eTSSOP-20
IS32LT3147	6	Linear	75	PWM	YES	eTSSOP-20
IS32LT3131 (ASIL-A)	12	Linear	75	PWM	YES	eTSSOP-28
IS32LT3134	12	LED Animation Controller	100	PWM	N.A.	WQFN-24
IS32LT3177	1	Linear	200	Power Supply PWM	N.A.	SOT23-6, eSOP8
IS32LT3178	1	Linear	200	Digital PWM	N.A.	SOT23-6, eSOP8





### IS32LT3131 & IS32LT3138 Features

	IS32LT3131	IS32LT3138
Supply voltage	4.5~40V	4.5V~16V
Quiescent current	20mA max	4.5mA typ. 6.5mA max.
Channel Numbers	12	18
Output Structure	Source	Sink
Max Output current	75mA/CH	100mA/CH
Global current setting Ratio	5bit	6bit
DC current setting	8bit	7bit
PWM dimming Ratio	10bit	12bit
PWM frequency Range	0-32KHz	244Hz [12-bit]/ 24KHz[7+5-bit]
Interface	SPI/UART/ CANLITE	UART
Support Addressable Device	16	64
Phase delay	Yes	Yes
Spread spectrum	Yes	Yes
Thermal sharing	Yes	No
LED open/short detection	Yes	Yes
Single LED short detection	Yes	Yes
ISSET pin short protection	Yes	Yes
One fail all fail/ on fail all on	Yes	No
Watchdog	Yes	Yes
Analog dimming	No	Yes
Internal ADC	Yes	No
Operation temp	-40°C to +150°C	-40°C to +150°C
Package	eTSSOP-28	WFQFN32/eTQFP32

### Key Advantages

- **IS32LT3131:**
  - 12-channels @ 75mA/ch
  - PWM/DC current/Global current of 10-bits/ 8-bits/5-bits
  - 10-bit ADC to measure each LED string voltage
  - Support 16 device addressing
  - ISO 26262 (ASIL-A) Fault protection and reporting
- **IS32LT3138:**
  - 18-channels @ 100mA/ch
  - PWM/DC current/Global current of 12-bits/ 7-bits/6-bits
  - Analog dimming input
  - Support 64 device addressing

### Application

- Animation Rear Light
- Animation Tail Light
- Animation Daytime Running Light



## IS32LT3131 Description

The IS32LT3131A/B/C is a 12-channel current source linear driver capable of delivering up to 75mA per channel. It integrates a 10bit ADC with 15 multiplexed inputs with register accessible ADC value storage. It supports bus error correction (CRC) and integrates a watchdog timer to automatically set failsafe modes when the bus interface connection is lost. The interface bus type is identified by part number suffix; 'A' - UART, 'B' - CANLITE, and 'C' - SPI

## IS32LT3138 Description

The IS32LT3138 is an 18-channel current sink linear driver capable of delivering up to 100mA per channel. It has a UART interface which is compatible with CANFD PHY for master MCU communication over a CAN Bus. It supports bus error correction (CRC) and integrates a watchdog timer to automatically set failsafe modes when the bus interface connection is lost. An external NTC thermistor can be connected to support LED temperature roll-off.

## Applications Diagrams for IS32LT3131

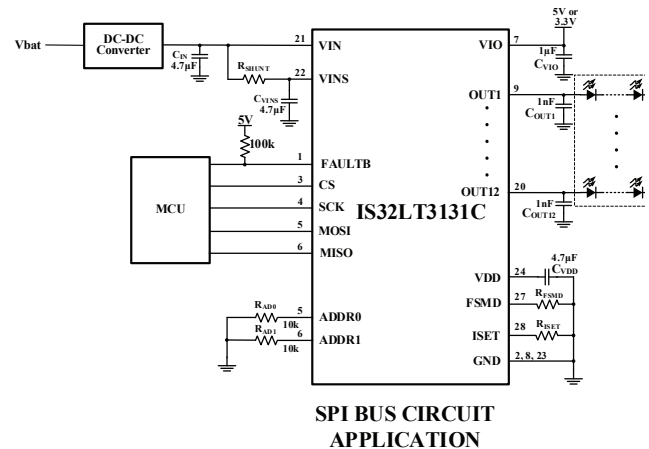
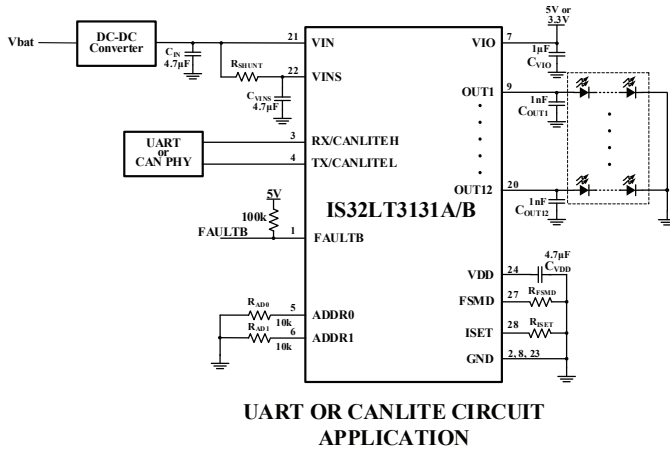

## Applications Diagram for IS32LT3138

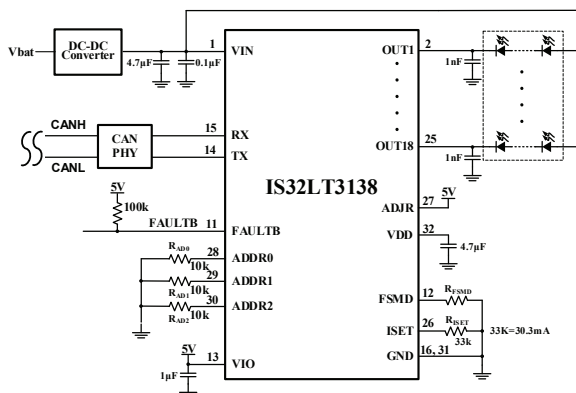

## Ordering Information

Device	Bus Interface	Speed	Package
IS32LT3131A-ZLA3-TR	UART	100s~1Mbps	eTSSOP-28
IS32LT3131B-ZLA3-TR	CANLITE	100s~1Mbps	eTSSOP-28
IS32LT3131C-ZLA3-TR	SPI	9MHz	eTSSOP-28
IS32LT3138-QWLA3-TR	UART	100s~1Mbps	WFQFN-32
IS32LT3138-TQLA3-TR	UART	100s~1Mbps	eTQFP-32



### IS32LT3146 Description

The IS32LT3146 is a six-channel sequential animation linear LED driver for automotive taillights. Each channel is a 75mA current source output controlled by an integrated sequence state machine. A logic level on the SEQEN pin switches between sequential turn or blink modes and external resistors adjust their timing; without a microcontroller. Multiple devices can be cascaded for supporting synchronization of more than 6 LED strings. An optional external resistor can be used for power off-load to ensure the IS32LT3146's power dissipation remains below  $P_{d(max)}$  for the required operating conditions.

### Features

- 5V~40V Operating Voltage
- 6 channels @ 75mA [resistor adj]
  - Low headroom of 0.9V [Max.] @ 75mA
- Resistive power shunt to off-load device thermal
- Sequential turn per channel
  - Timing resistor with  $\pm 5\%$  timer accuracy
  - Synchronized sequential for multiple device operation
  - Sequential turn style selectable
  - Single pin selection for sequential turn or traditional blink
- Current slew rate control to optimize EMI performance
- Operating temperature range [-40°C ~ +150°C]
- AEC-Q100 Qualified

### IS32LT3147 Description

The IS32LT3147 is a six-channel linear LED driver with each channel being a 75mA current source output with its own individual PWM control. An optional external resistor can be used for power off-load to ensure the IS32LT3147's power dissipation remains below  $P_{d(max)}$  for the required operating conditions.

### Features

- 5V~40V Operating Voltage
- 6 channels @ 75mA [resistor adj]
  - Low headroom of 0.9V [Max.] @ 75mA
- Resistive power shunt to off-load device thermal
- Individual PWM dimming to each channel
- Current slew rate control to optimize EMI performance
- Operating temperature range [-40°C ~ +150°C]
- AEC-Q100 Qualified

### Applications Diagrams

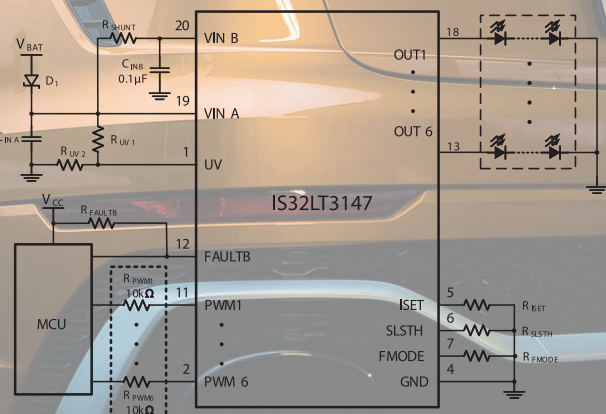
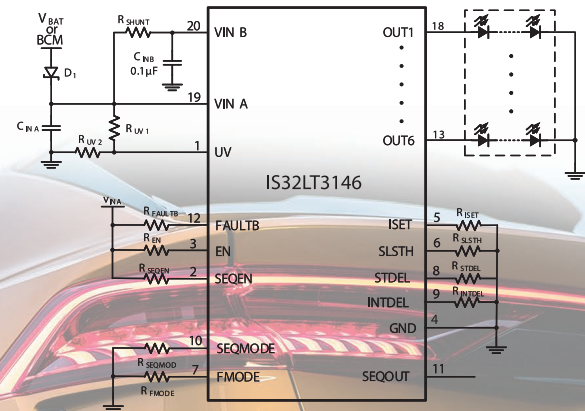

### Ordering Information

Part Number	Bus	Package
IS32LT3146-ZLA3-TR	N/A, Standalone	eTSSOP-20
IS32LT3147-ZLA3-TR	N/A, 6 PWM Inputs	eTSSOP-20

## Description

Capacitive touch sensing enables aesthetic design and superb in-car experience. Extending from traditional infotainment center-stack to a variety of user interfaces throughout the vehicle such as illumination controls, indoor & outdoor touch sensor switches, liquid level sensors and many others.

The Lumissil touch sensor solutions enable product designers to quickly replace mechanical buttons with sleek and reliable capacitive-sensing user interfaces.

Bringing to the market a reliable and flexible solution, working through different user interfaces (button, wheel, slider, proximity, etc.), surface materials (plastic, wood, etc.), wide environmental conditions (humidity, temperature) and user-touch interface (gloves, wet or dirty surface, etc.). This in turn is critical to determine the user satisfaction of the human-machine interaction.

Utilizing the programmable capabilities of the Lumissil touch sense solution enables a range of system solutions starting with direction, proximity or gesture recognition, going through providing visual (LED, STN-LCD) and audio feedback, as well as ability for in-line communication with other elements in the vehicle.

## Touch Sense Management

### Robust & reliable operation

- Automotive grade touch key controller
- Robust noise immunity to changing environments, without the need for manual tuning
- Liquid tolerance algorithm for wet/moist environments
- Reliable under noise, humidity, temperature
- Supports proximity sensing distance
- Versatile touch-sensing

### Enabled through plastic, glass, wood

- Liquid tolerance algorithm
- Gloved hands operation
- Buttons, Sliders, wheels & Proximity sensor

### Easy & Flexible configuration

- Self tuning capacitor touch
- Flexible number of touch sensors
- Integrated touch sensor & LED driver solutions
- I/O configurability - SPI, I2C, UART, LIN, CAN, etc.
- User-friendly GUI for quick configuration and characterization
- Browser based flash programming tooling
- Low power consumption by ULL process

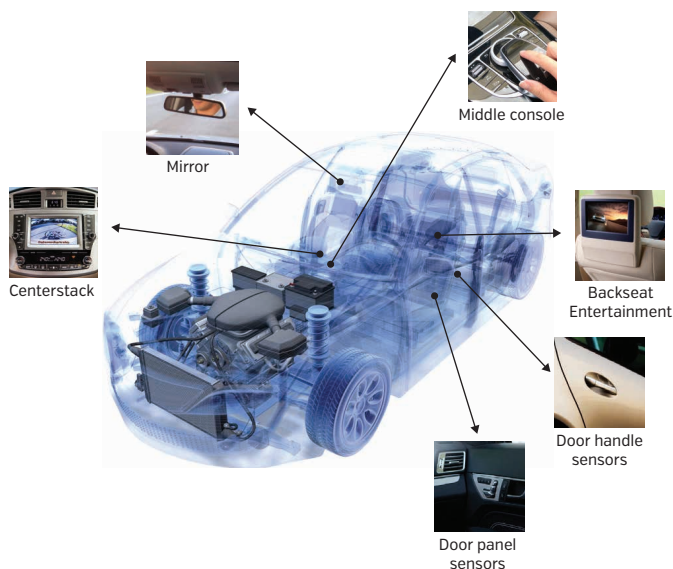

Automotive Touch Sensor Applications

## Ordering Information

Part Number	Number of Channels	Package	Key features	Enhanced Features
IS32SE5117	16	WQFN-24 [4x4]	E-Flash and SRAM with built-in ECC, water resistant, proximity sensor, and melody generator	SPI, I2C, 6-ch PWM16, 10-bit DAC, LIN, Buzzer, AEC-Q100
IS32SE5118	8	TSSOP-16 [6.4x5]	E-Flash and SRAM with built-in ECC, water resistant, proximity sensor, and melody generator	SPI, I2C, 12-ch PWM8, 12-bit DAC, LIN, Buzzer, Stable AC Transient Response, AEC-Q100 Pending
IS32SE5120	24	QFN-32 [5x5]	E-Flash and SRAM with built-in ECC, water resistant, and melody generator	Proximity sensing, SPI, 12-bit DAC, buzzer, AEC-Q100

P.S.: TK1: Oscillator Type; TK2: Charge Transfer Type



# CAPACITANCE TOUCH SENSORS

## Touch-Sense & Proximity Sensing

### IS32SE5120 Features

- 24-channel capacitive touch controller with readable key value
- Flexible GPIO setting
- Touch threshold setting for individual key
- Optional multiple-key function
- Press and hold function
- Automatic calibration
- Individual key calibration
- Interrupt output with auto-clear and repeating
- Auto sleep mode for extremely low power
- Keys wake up from sleep mode
- Shield output shared with touch key channels
- Buzzer/Melody Generator shared with touch key channels
- 400kHz fast-mode I<sup>2</sup>C interface
- Operating temperature between -40°C ~ +105°C
- Compact QFN-32 pin package

### Key Advantages

- Touch and proximity application using a single device
- Offers MCU and sensor application in a single chip
- Application specific features reduce design cycle time and speed up time to market
- User friendly design tools - Evaluation boards and GUI
- Comes from family of successful and proven automotive MCUs/Sensors
- Packaged in auto AEC qualified compact QFN 32-pin package, high reliability & small PCB

### Applications

- Auto door handle proximity sensor
- Touch sensitive sunroof
- Rear seat entertainment system
- Instrument cluster
- Door window control module

### Application Diagram

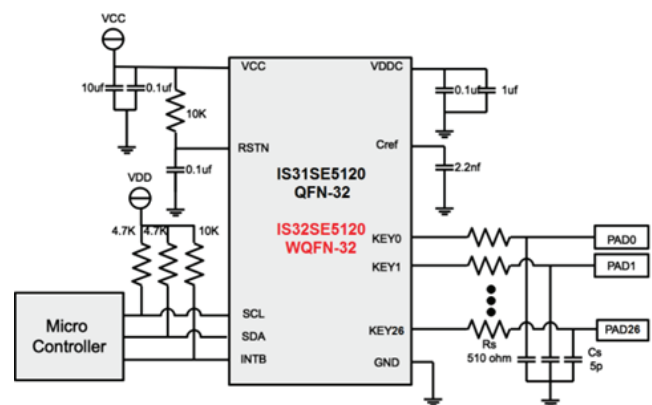

### Ordering Information

Part Number	Package
IS32SE5120-QFLS3-TR	24 Ch. Cap Touch input through shared GPI, QFN-32 [5mm x 5mm in T&R]



Door panel sensors



Backseat Entertainment



Door handle sensors

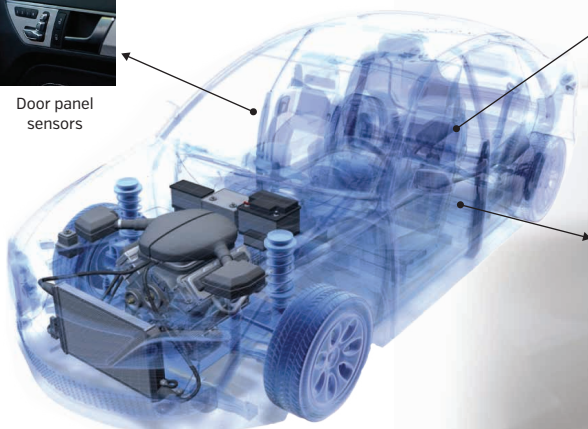

IS32SE5120 Automotive Touch Sensor Applications



# MCUs

## Description

Lumissil automotive MCUs have 16KB to 64KB of embedded-flash memory and 1-2KB of embedded SRAM for data manipulations. Both SRAM and e-Flash implement built-in ECC that correct 1-bit error and detect two-bit errors. CPU can access the e-Flash through program address read and through Flash Controller which can perform software read/write operations of e-Flash for EEPROM emulations. CPU is 1-T 8051 with enhanced multiplication and division accelerator. There are T0/T1/T2/T3/T4/T5 timers coupled with CPU and two WDT where WDT0 is clocked by SYSCLK, and WDT2/WDT3 are clocked by a non-stop SIOSC. An 8-bit/16-bit checksum and 16-bit CRC accelerator is included. There are EUART/LIN controller and I2C master/Slave controller as well as SPI master/slave controller. The interfaces of these controllers are with GPIO pins. Other useful peripherals include a buzzer/melody control. Analog peripherals include touch key controllers up to 20-bit resolution employing dual-slope charge sharing capacitance conversion. The touch key controller has shield output capability for moisture immunity.

## Touch Sense Management

### Robust & reliable operation

- Automotive MCUs based on industry standard 8-bit 8051
- LIN, CAN, UART, ADC, DAC, PWM, Analog Comparator, I2C, SPI Interface
- Embedded Flash microcontrollers based on the high-performance 8-bit 8051
- A comprehensive set of power-saving modes allows low-power designs
- Frequency range from 8MHz up to 125MHz [if implemented PLL] to enhance end-product performance
- Integrate Analog, MCU and Memory for SOC solutions
- Touch key Control with LED/STN-LCD Driver for Auto applications
- Watchdog timers with multiple choices of clock source

## Application

- Automotive Comfort systems - Networked [CAN/LIN] ambient/head light controlled by auto grade MCU
- Automotive Safety Systems - Networked [CAN/LIN] animated stop/tail light, ADB Matrix headlights, Ignition, alternator regulator, etc.
- BDC/BLDC motor drivers, e.g., door and trunk lock gear motors and grill shutters, seat motors, radiator/condenser/ seat cooling fans, power windows, sunroof, actuator, etc.
- System Diagnostics Functions - Monitor and report systems status - Voltage, power, Temp, air quality sensor, etc.

## Ordering Information

Part Number	Flash/ RAM (ECC)	Package	Key features	Enhanced Features
IS32CS8974	32KB/2KB	TSSOP-24, WQFN-24	16 MHz clock, 20 GPIOs, Master/Slave I2C, UART/ EUART/LIN controller, SPI, WDT, 19 Sigma-Delta Cap.Touch sensors	SPI, I2C, 6-ch PWM16, 10-bit DAC, LIN, Buzzer, AEC-Q100
IS32CS8975	16KB/1KB	TSSOP-16, SOP-8	32 MHz clock, 12 GPIOs, Master/Slave I2C, UART/ EUART/LIN controller, SPI, WDT, 11 Sigma-Delta Cap.Touch sensors	SPI, I2C, 12-ch PWM8, 12-bit DAC, LIN, Buzzer, Stable AC Transient Response, AEC-Q100 Pending
IS32CS8977	64KB/2KB	TSSOP-16/24/28, WQFN-32, LQFP-32	132 MHz clock, 28 GPIOs, Master/Slave I2C, UART/ EUART/LIN controller, SPI, WDT, 27 Sigma-Delta Cap.Touch sensors	SPI, I2C, RTC, 6-ch PWM16, 2-ch PWM8, 12-bit DAC, LIN, Buzzer, Stable AC Transient Response, AEC-Q100 Pending





## IS32CS8977 Features

- Automotive MCUs based on industry standard 32MHz 8-bit 8051
- 2KB RAM and 64KB ECC embedded Flash
- LIN, UART, ADC, DAC, PWM, Analog Comparator, I2C, SPI Interface
- Comprehensive set of power-saving modes allows low-power designs
- Integrate Analog, MCU and Memory for SOC solutions
- Touch key Control with LED/STN-LCD Driver for Auto applications
- Watchdog timers with multiple choices of clock source
- Shield output shared with touch key channels
- Buzzer/Melody Generator shared with touch key channels
- Temperature sensor for alerts
- Operating temperature between -40°C ~ +105°C
- Compact 20-pin TSSOP package [other package options are also available]

## Key Advantages

- Offers MCU and touch/proximity sensor application in a single chip
- Application specific features reduce design cycle time and speed up time to market
- User friendly design tools - Evaluation boards and GUI
- Comes from family of successful and proven automotive MCUs
- Packaged in AEC qualified compact 20-pin TSSOP package - high reliability and smaller PCB

## Applications

- Instrument cluster module
- Trunk release
- Touch sensitive electric roof
- Seat tensioner
- Door window combo control module

## Ordering Information

Part Number	Package
IS32CS8977-QFLS2-TR	MCU with 2KB SRAM and 64Kx16 ECC E-Flash, 5mmx5mm, QFN-32

## Application Diagram

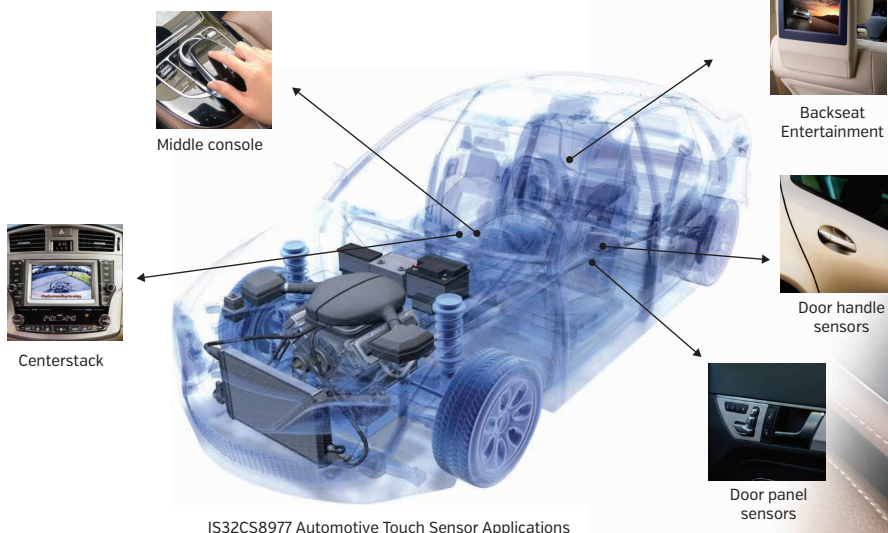
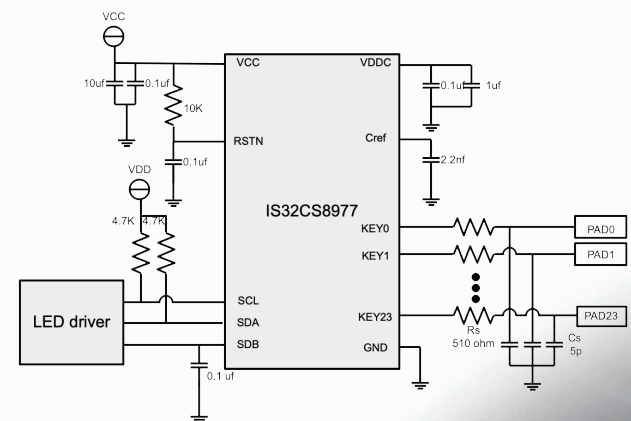

Backseat Entertainment



Door handle sensors



Door panel sensors



### IS32IO1163 Features

- High-speed CAN FD data frames up to 5Mbit/s
- Compliant to ISO 11898-2/5/6
- Built-in LDO [5V/100mA] output pin V1 to supply external microcontroller
- 5V nominal output; +/- 2% accuracy on pin V1
- 100mA output current capability at V1 and with short-circuit protection to GND
- Optimized for low electromagnetic emission [EME]
- Wide common mode range [CMR], +12V~-12V, to optimize for a high immunity against electromagnetic interference [EMI]
- Very low quiescent current [Typ. 75uA] in Standby mode with full remote wake-up capability
- Under voltage detection at V1 and BAT
- VIO input allows for direct interfacing with microcontrollers.
- Over temperature shut-down
- Standard pin out and TSSOP-14 with exposed pad package
- Automotive AEC-Q100 qualification in progress

### Applications

- Automotive subsystems such as head light control module
- Tail and turn light signal module
- Roof control with interior lighting module
- HVAC control module
- Body control module and many other subsystems

### IS32IO1028 Features

- LIN 2.X/SAE J2602 compliant
- BUS pin support up to 20kBaud
- Operating Voltage VBAT= 5.5V to 32V
- Withstand +40V/-24V
- 3.3V/5.0V options
- +/- 5% accuracy
- Up to 70mA load
- Build-in LDO output on VCC pin for supplying external components
- Short circuit protection with current limiting
- Sleep mode and Wakeup
- Low current consumption in Sleep mode.
- LIN bus wake-up function
- Local wake-up from EN pin
- Over temperature shut-down
- Auto AEC-Q100 qualification in progress

### Applications

- **Steering wheel:** Cruise control, wiper, climate control, radio
- **Comfort:** Sensors for temperature, sun-roof, light, humidity
- **Powertrain:** Sensors for position, speed, pressure
- **Engine:** Small motors, cooling fan motors
- **Air condition:** Motors, control panel
- **Door:** Side mirrors, windows, seat control, locks
- **Seats:** Position motors, pressure sensors

### Key Advantages for IS32IO1163 & IS32IO1028

- Open source hardware & software – hardware schematic diagram, PCB design, BOM, OS & driver software packages
- Core module – design stamp-holes for mass production capability
- Processor – a compute engine as well as a control MCU
- Connectivity – Ethernet, USB, SSI, UART, PWM, ADC, I2C

### Ordering Information

Part Number	Package
IS32IO1163A-ZLA3-TR	CAN FD controller in T&R, TSSOP-14 [VIO internal connects to V1]
IS32IO1163B-ZLA3-TR	CAN FD controller in T&R, TSSOP-14 [Independent VIO pin]
IS32IO1028A-GRLA3-TR	LIN Transceiver with LDO, SOP-8, Vcc=5.0V
IS32IO1028B-GRLA3-TR	LIN Transceiver with LDO, SOP-8, Vcc=3.3V

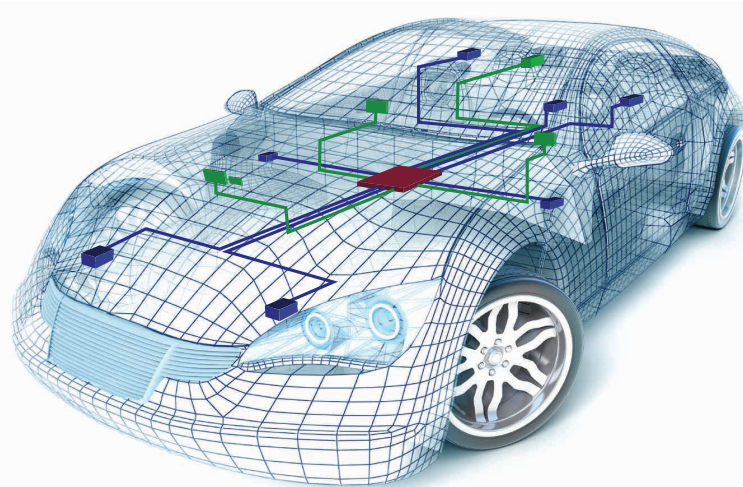



### Description

Backbone to transport all automotive protocols (Ethernet, CAN, LIN, FlexRay etc) transparently. Enables zonal architecture IVN that reduces wiring, simplifies manufacturing, and maintenance/repairs without changes to existing ECUs (HW & SW) and associated communication protocols.

### Applications

- Automotive In-Vehicle Networking (IVN)

### Features List

- Automotive OFDM layer 2 communication technology based on ITU-T's G.9960 standards
- Transports all automotive communication protocols transparency with low/bounded latency
- Practical migration path from current function-based network to future IP-based network.
- "Harness immunity" – generates metric to assess health of the wire harness
- Integrated Analog Front End
- Dual host interface: SPI1 or SPI2 and RGMII
- IEEE1588 support
- 8x8mm aQFN, -40°C to +105°C, AEC-Q100 grade 2

### Ordering Information

Part Number	Description
CG5316B0-A2NE3	CG5316, G.vn Transceiver for in vehicle networking, aQFN80 (8x8), automotive grade, Green

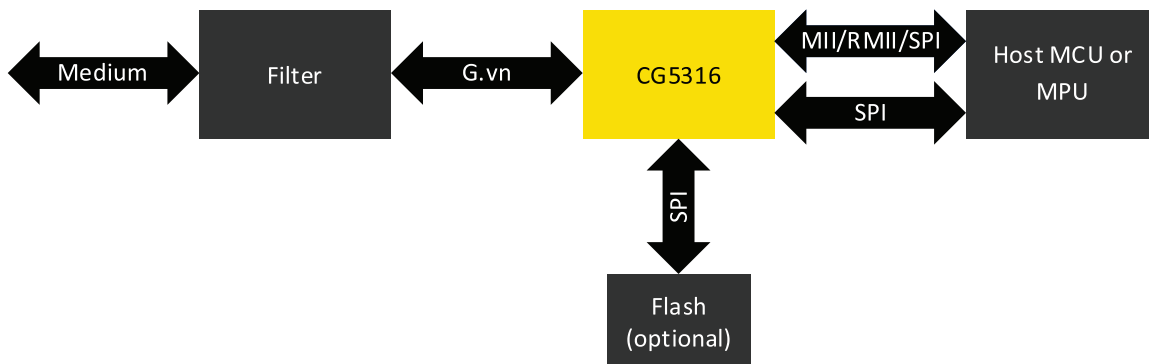
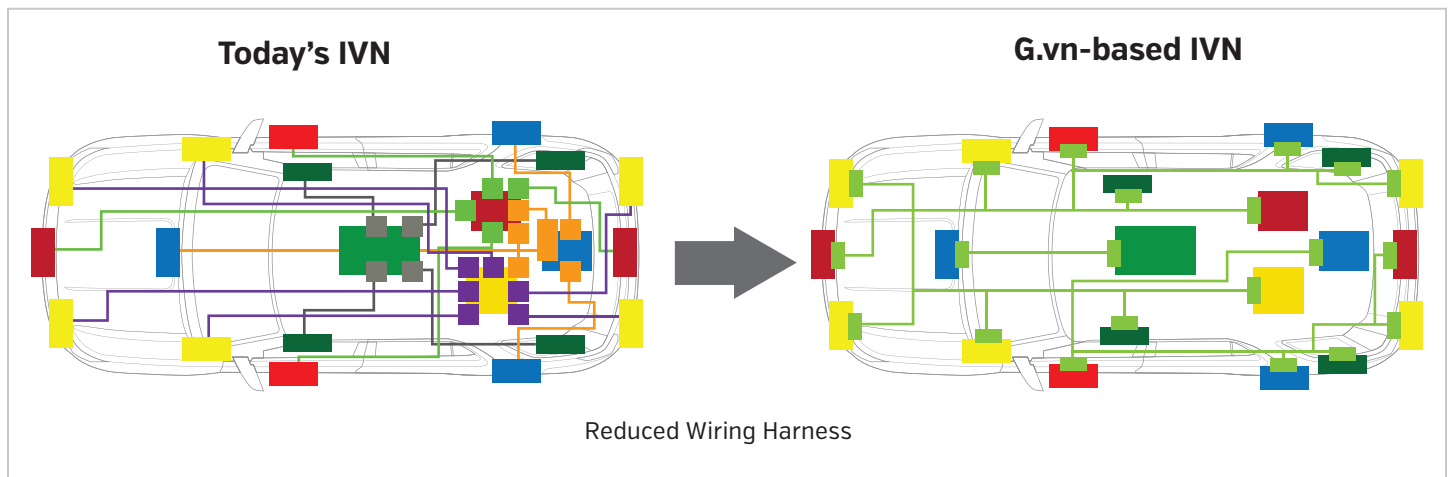

### Description

Required by global dominant charging standard, CCS (Combined Charging Standard) for communications between vehicle and charger. CCS adopts ISO/IEC 15118 specifications. World's first automotive grade HPGP transceiver for use in both Vehicle [EV] and Charger [EVSE]

### Applications

- EV Vehicle Charging Port
- EVSE Charger Station

### HPGP IS32CG5317 Features

- HomePlug Green PHY standard compliant transceiver for basic EV charging application
- HomePlugAV standard compliant for high-rate applications data exchange during charging
- TX Signal:
  - dBm – complies with ISO15118-3 and DIN 70121 PSD calibration requirements
  - Support optional external line driver for further boosting of the signal (not required in typical applications)
  - Configurable PSD (per tone configuration)
  - Simple PSD calibration process
- Dual host Interface: R/MII, or SPI (configurable clock speed up to 50MHz)
- Boot:
  - FW loading from Host (MCU)
  - Optional FW loading from Flash
- Highly flexible diagnostics capabilities
  - SNR, Noise, Channel, gain, various statistics
  - Ability to stream out logs (depending on support from the Host side)
- Embedded PVT (Process, Voltage, Temperature) sensor
- Embedded eFUSE memory
- RoHS-compliant EP-LQFP 80pin 12x12mm package, -40°C to 105°C, AEC-Q100 qualified

### Ordering Information

Part Number	Description
IS32CG5317-LQLA2-TR	Automotive grade, Tape & Reel packaging. CG5317, HomePlug Green PHY Transceiver, EP-LQFP80.
IS32CG5317-LQLA2	Automotive grade, Tray packaging. CG5317, HomePlug Green PHY Transceiver, EP-LQFP80.
IS31CG5317-LQLS3-TR	Industrial grade, Tape & Reel packaging. CG5317, HomePlug Green PHY Transceiver, EP-LQFP80. [-40 °C +105°C]
IS31CG5317-LQLS3	Industrial grade, Tray packaging. CG5317, HomePlug Green PHY Transceiver, EP-LQFP80. [-40°C +105°C]

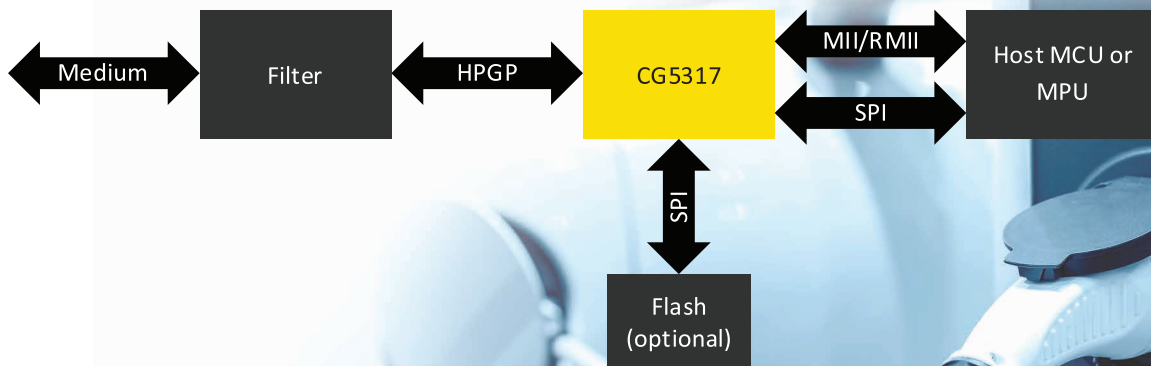



# MORE INFORMATION

## Analog Part Decoder

IS 31 LT 3135 V1 - GR L S2 - TR

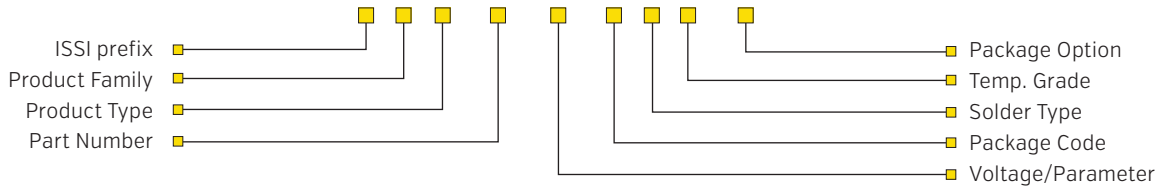

### Analog Product Family

- 31 = Commercial/Industrial Analog
- 32 = Automotive Analog and Mixed Signal

### Product Type

- AP = Audio Power Amplifier
- AS = ASIC
- BL = White LED Driver for LCD Backlight
- CG = Connectivity
- CS = MCU Auto and non-Auto
- FB = Fiber
- FL = FxLED Driver
- IO = Multi-Function I/O Expander, CAN, LIN
- LT = Lighting LED Driver
- NM = Networking
- PM = Power Management
- SE = Sensor

### Temperature Grade

- S1 = Commercial [0°C to 70°C]
- S2 = Industrial temp. [-40°C to 85°C]
- S3 = Industrial temp. [-40°C to 105°C]
- S4 = Industrial temp. [-40°C to 125°C]
- A1 = Automotive Grade [-40°C to +85°C]
- A2 = Automotive Grade [-40°C to +105°C]
- A3 = Automotive temp. [-40 to 125°C]
- A4 = Automotive temp. [-40 to 150°C]

### Solder Type

- Blank = Sn/Pb
- L = Lead-free (RoHS Compliant)

### Package Type

- C = WCSP, FCQFN
- D = DFN
- GR = SOP
- QF = QFN
- LQ = eLQFP
- S = MSOP
- SA = SSOP
- SD = SOT89
- ST = SOT23
- TQ = TQFP
- TT = TSOT
- UT = UTQFN
- QW = Wettable flank QFN
- QU = UQFN
- Z = eTSSOP

### Voltage Range / Parameters

- Sense Voltage Range**
- V1 = 91mV to 101mV
- V2 = 99mV to 110mV
- Under-Voltage Range**
- V1 = 1.13V to 1.21V
- V2 = 1.19V to 1.26V

### Package Option

- Blank = Tray or Tube
- TR = Tape & Reel

## Lumissil Locations

