

12-CHANNEL LED DRIVER EVALUATION BOARD GUIDE

DESCRIPTION

IS31FL3206 is comprised of 12 constant current channels each with independent PWM control, designed for driving LEDs, PWM frequency can be 24kHz (default) or 3.6kHz. The output current of each channel can be set at up to 38mA (Max.) by an external resistor and independently scaled by a factor of 1, 11/12, 9/12 and 7/12. The average LED current of each channel can be changed in 256 steps by changing the PWM duty cycle through an I2C interface.

The chip can be turned off by pulling the SDB pin low or by using the software shutdown feature to reduce power consumption.

FEATURES

- 2.7V to 5.5V supply
- I2C interface, automatic address increment function
- Modulate LED brightness with 256 steps PWM
- Each channel can be scaled independently by 1, 11/12, 9/12 and 7/12
- PWM frequency selectable
 - 24kHz (default)
 - 3.6kHz
- -40°C to +125°C temperature range
- QFN-20 (3mm × 3mm) package

QUICK START



Figure 1: Photo of IS31FL3206 Evaluation Board

RECOMMENDED EQUIPMENT

- 5.0V, 2A power supply

ABSOLUTE MAXIMUM RATINGS

- ≤ 5.5V power supply

Caution: Do not exceed the conditions listed above, otherwise the board will be damaged.

PROCEDURE

The IS31FL3206 evaluation board is fully assembled and tested. Follow the steps listed below to verify board operation.

Caution: Do not turn on the power supply until all connections are completed.

- 1) If using external DC power supply connect the ground terminal of the power supply to the evaluation board's GND pin and the positive terminal to the VCC pin. The evaluation board can also be powered via the Micro USB connector.
- 2) Short JP1 to close external control.
- 3) Turn on the power supply/Plug in the Micro USB and pay attention to the supply current. If the current exceeds 1A, please check for circuit fault.
- 4) Enter the desired mode of display by toggling the MODE button (K1).

EVALUATION BOARD OPERATION

The IS31FL3206 evaluation board has five display modes. Press K1 to switch configurations:

Note: See Appendix for each mode's detail.

- 1) Two groups single color LEDs chasing each other-A.
- 2) Two groups single color LEDs chasing each other-B.
- 3) Three groups single color LEDs chasing after each other.
- 4) Chasing cycle.
- 5) RGB LEDs (RGB1-RGB4) are breathing effect A-mixed color.
- 6) RGB LEDs (RGB1-RGB4) are breathing effect B.

Note: IS31FL3206 solely controls the FxLED function on the evaluation board.

ORDERING INFORMATION

Part No.	Temperature Range	Package
IS31FL3206-QFLS4-EB	-40°C to +125°C, Industrial	QFN-20, Lead-free

Table 1: Ordering Information

For pricing, delivery, and ordering information, please contact Lumissil's analog marketing team at analog@lumissil.com or (408) 969-6600.

12-CHANNEL LED DRIVER EVALUATION BOARD GUIDE

SOFTWARE SUPPORT

JP1 (EXT CTRL) default setting is closed (jumper on). If it is open (when the EVB is powered on by 5V DC or micro-USB, no jumper JP1), the on-board MCU will configure its own I2C/SDB/AD pins to High Impedance status so an external source can driver the I2C/SDB signals to control the IS31FL3206 LED driver, the on-board MCU will also configure the U4 to open the VLED (Single color LED+) and close the VRGB.

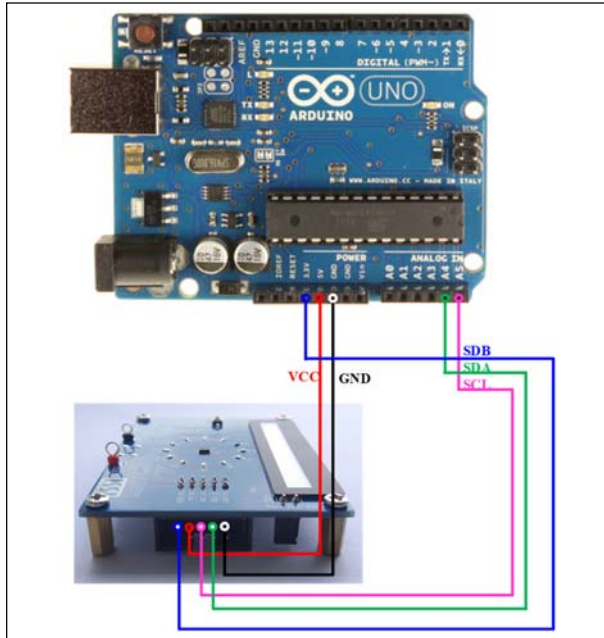

Figure 2: Photo of Arduino UNO connected to Evaluation Board

The steps listed below are an example using the Arduino for external control.

The Arduino hardware consists of an Atmel microcontroller with a bootloader allowing quick firmware updates. First download the latest Arduino

Integrated Development Environment IDE (1.6.12 or greater) from www.arduino.cc/en/Main/Software. Also download the Wire.h library from www.arduino.cc/en/reference/wire and verify that pgmspace.h is in the directory ...program Files(x86)/Arduino/hardware/tools/avr/avr/include/avr/. Then download the latest IS31FL3206 test firmware (sketch) from the Lumissil website <http://www.lumissil.com/products/led-driver/fxled>.

- 1) Open JP1.
- 2) Connect the 5 pins from Arduino board to IS31FL3206 EVB:
 - a) Arduino 5V pin to IS31FL3206 EVB VCC.
 - b) Arduino GND to IS31FL3206 EVB GND.
 - c) Arduino SDA (A4) to IS31FL3206 EVB SDA.
 - d) Arduino SCL (A5) to IS31FL3206 EVB SCL.
 - e) If Arduino use 3.3V MCU VCC, connect 3.3V to IS31FL3206 EVB SDB, if Arduino use 5.0V MCU VCC, connect 5.0V to EVB SDB.
(Arduino UNO is 5.0V, so SDB=5.0V)
- 3) Use the test code in appendix I or download the test firmware (sketch) from the Lumissil website, a .txt file and copy the code to Arduino IDE, compile and upload to Arduino.
- 4) Run the Arduino code and the initial mode will change the Blue LED brightness every second. Note: the white color LEDs cannot be controlled when the onboard STM32F103C8T6 is disabled. (Some early board we provided is still controlling the single color LED, if want to switch between single color LED and RGB, remove the U4 and connect the VCC to the LED+)

Please refer to the datasheet to get more information about IS31FL3206.

12-CHANNEL LED DRIVER EVALUATION BOARD GUIDE

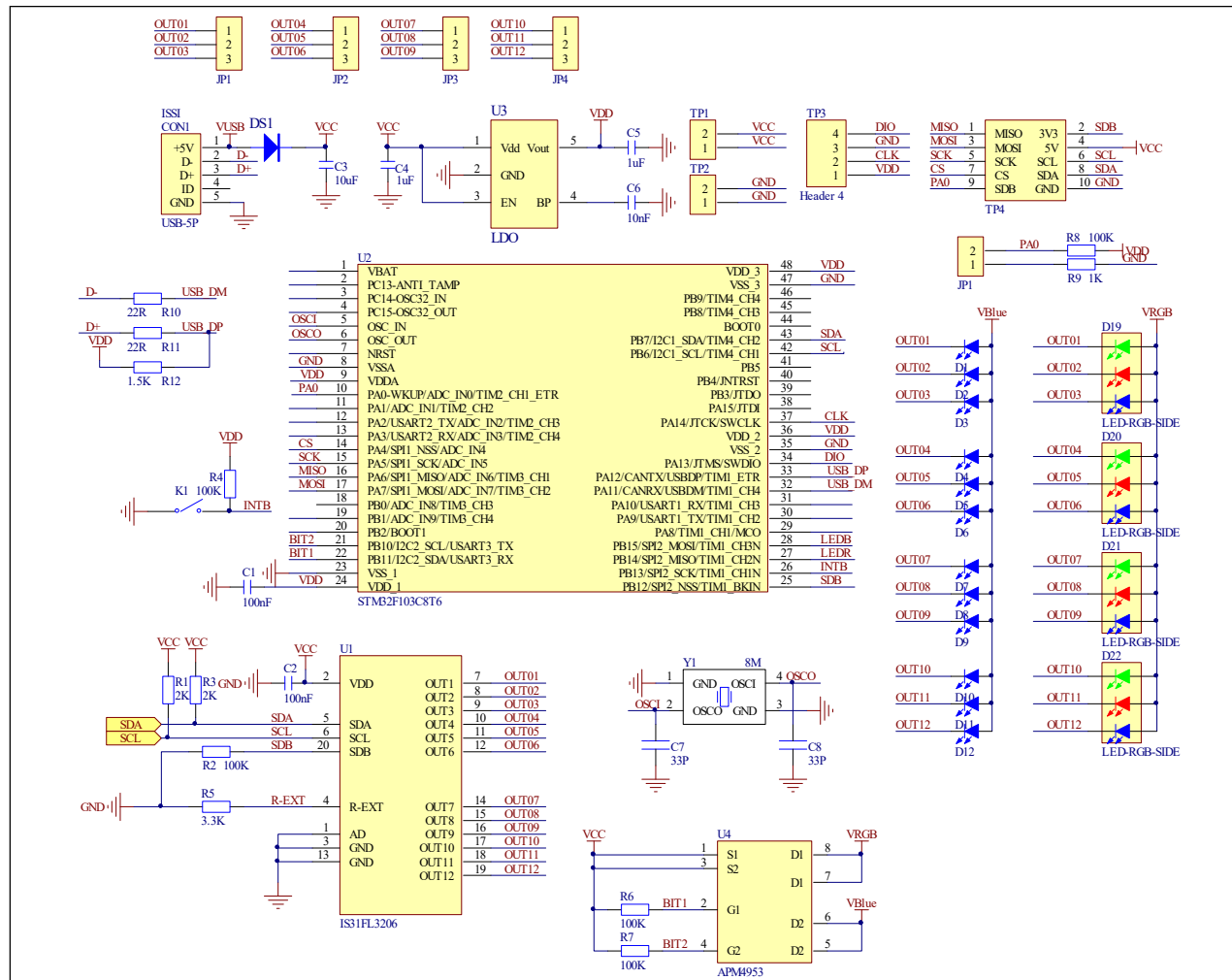

Figure 3: IS31FL3206 Application Schematic

12-CHANNEL LED DRIVER EVALUATION BOARD GUIDE

BILL OF MATERIALS

Name	Symbol	Description	Qty	Supplier	Part No.
LED Driver	U1	Matrix LED Driver	1	Lumissil	IS31FL3206
MCU	U2	Microcontroller	1	STM	STM32F103C8T6
LDO	U3	3.0V LDO	1	SGMICRO	SGM2019-3.0YN5G
PMOS	U4	PMOS	1	ANPEC	APM4953
LED	D1~D12	LED, SMD Blue	12	EVERLIGHT	19-217/BHC-AN1P2/3T
RGB LED	D19~D22	RGB LED, SMD	4	EVERLIGHT	99-235/RSGBB7C-A22/2D or 99-235/RGBC/TR8
Diode	DS1	Diode, SMD	1	DIODES	DFLS240
Crystal	Y1	Crystal, 8MHz	1	HLX	HC-49S
Resistor	R2,R4, R6,R7,R8	RES,100k,1/10W,±5%,SMD	5	Yageo	RC0603JR-07100KL
Resistor	R1,R3	RES,2k,1/10W,±5%,SMD	2	Yageo	RC0603JR-072KL
Resistor	R9	RES,1k,1/10W,±5%,SMD	1	Yageo	RC0603JR-071KL
Resistor	R5	RES,3.3k,1/10W,±5%,SMD	1	Yageo	RC0603JR-073K3L
Resistor	R10,R11	RES,22R,1/10W,±5%,SMD	2	Yageo	RC0603JR-0722RL
Resistor	R12	RES,1.5k,1/10W,±5%,SMD	1	Yageo	RC0603JR-071K5L
Capacitor	C1,C2	CAP,100nF,16V,±20%,SMD	2	Yageo	CC0603MRX7R7BB104
Capacitor	C3	CAP,10µF,16V,±20%,SMD	1	Yageo	CC0603MRX5R7BB106
Capacitor	C4,C5	CAP, 1µF,16V,±10%,SMD	2	Yageo	CC0603KRX7R7BB105
Capacitor	C6	CAP,10nF,16V,±10%,SMD	1	Yageo	CC0603KPX7R7BB103
Capacitor	C7,C8	CAP,33pF,50V,±5%,SMD	2	Yageo	CQ0603JRNPO9BN360
Button	K1(Bottom)	Button	1		
Micro USB	CON1	Micro USB	1		

Bill of Materials, refer to Figure 3 above.

12-CHANNEL LED DRIVER EVALUATION BOARD GUIDE

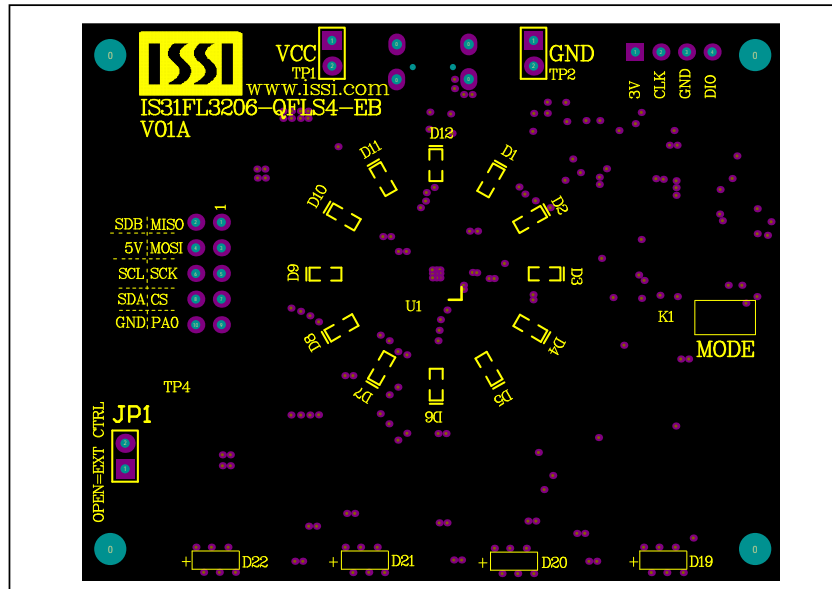

Figure 4: Board Component Placement Guide - Top Layer

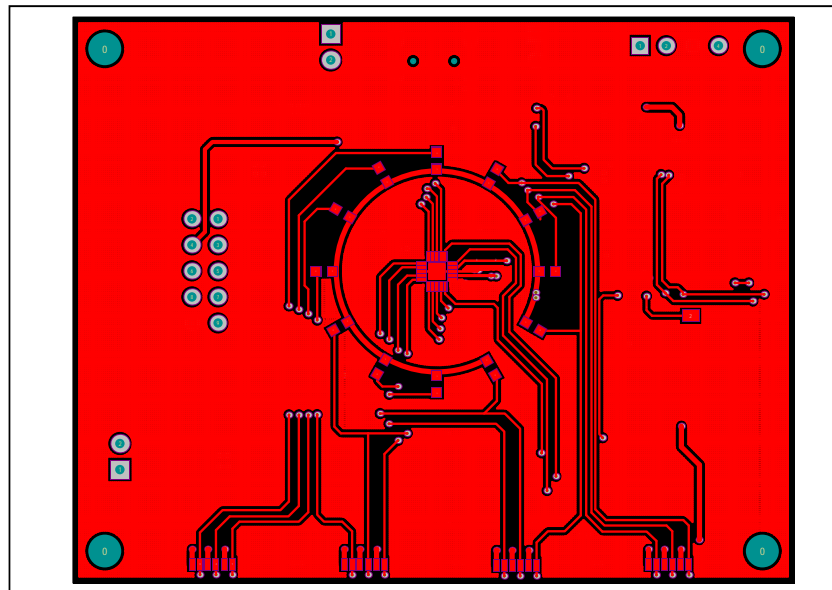

Figure 5: Board PCB Layout - Top Layer

12-CHANNEL LED DRIVER EVALUATION BOARD GUIDE

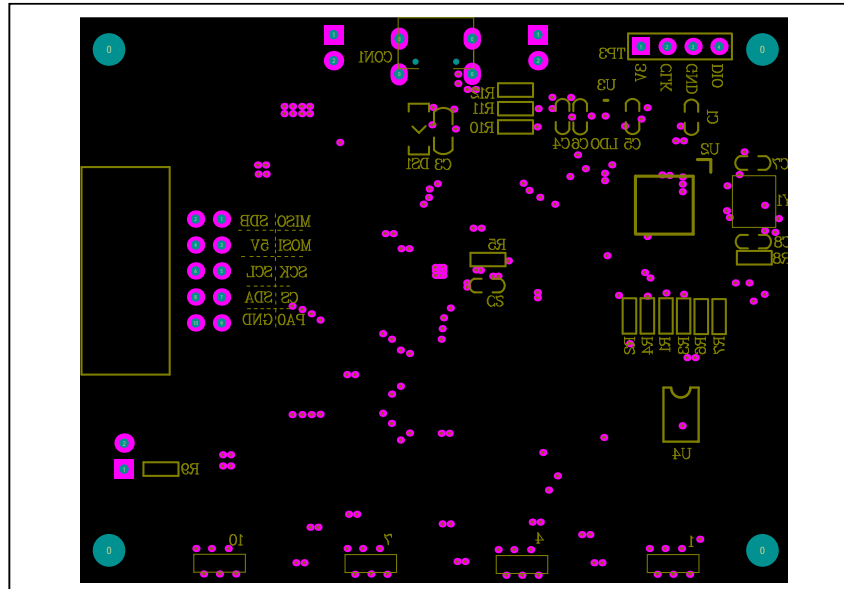

Figure 6: Board Component Placement Guide - Bottom Layer

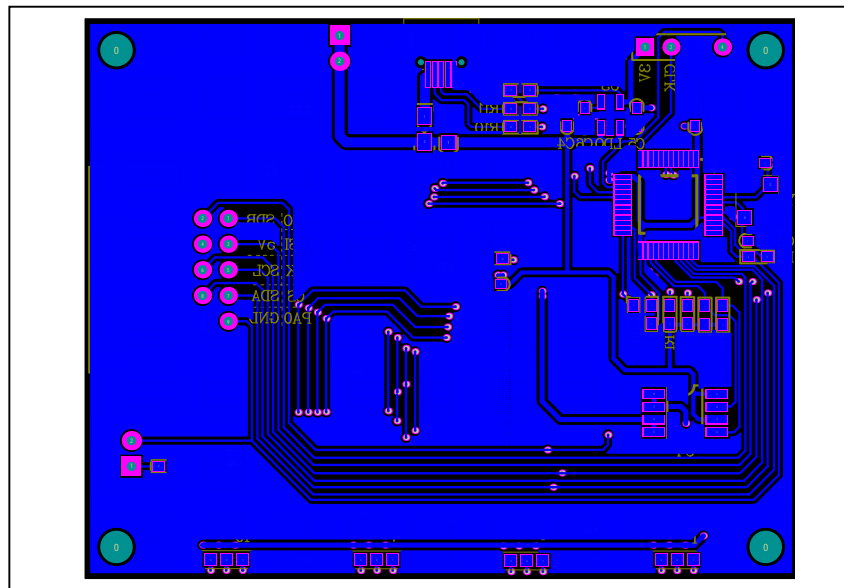

Figure 7: Board PCB Layout - Bottom Layer

Copyright © 2021 Lumissil Microsystems. All rights reserved. Lumissil Microsystems reserves the right to make changes to this specification and its products at any time without notice. Lumissil Microsystems assumes no liability arising out of the application or use of any information, products or services described herein. Customers are advised to obtain the latest version of this device specification before relying on any published information and before placing orders for products.

Lumissil Microsystems does not recommend the use of any of its products in life support applications where the failure or malfunction of the product can reasonably be expected to cause failure of the life support system or to significantly affect its safety or effectiveness. Products are not authorized for use in such applications unless Lumissil Microsystems receives written assurance to its satisfaction, that:

- a.) the risk of injury or damage has been minimized;
- b.) the user assume all such risks; and
- c.) potential liability of Lumissil Microsystems is adequately protected under the circumstances

12-CHANNEL LED DRIVER EVALUATION BOARD GUIDE

REVISION HISTORY

Revision	Detail Information	Date
A	Initial release	2018.07.18
B	Update the BOM	2021.05.08

12-CHANNEL LED DRIVER EVALUATION BOARD GUIDE

APPENDIX I : IS31FL3206 Arduino Test Code V01A

```

#include<Wire.h>
#include<avr/pgmspace.h>
#define Addr_GND 0xD8
//7 bit format is 0x3F

const PROGMEM byte PWM_Gama64[128]=
{
  0x00,0x01,0x02,0x03,0x04,0x05,0x06,0x07,
  0x08,0x09,0x0b,0x0d,0x0f,0x11,0x13,0x16,
  0x1a,0x1c,0x1d,0x1f,0x22,0x25,0x28,0x2e,
  0x34,0x38,0x3c,0x40,0x44,0x48,0x4b,0x4f,
  0x55,0x5a,0x5f,0x64,0x69,0x6d,0x72,0x77,
  0x7d,0x80,0x88,0x8d,0x94,0x9a,0xa0,0xa7,
  0xac,0xb0,0xb9,0xbf,0xc6,0xcb,0xcf,0xd6,
  0xe1,0xe9,0xed,0xf1,0xf6,0xfa,0xfe,0xff,

  0xff,0xfe,0xfa,0xf6,0xf1,0xed,0xe9,0xe1,
  0xd6,0xcf,0xcb,0xc6,0xbf,0xb9,0xb0,0xac,
  0xa7,0xa0,0x9a,0x94,0x8d,0x88,0x80,0x7d,
  0x77,0x72,0x6d,0x69,0x64,0x5f,0x5a,0x55,
  0x4f,0x4b,0x48,0x44,0x40,0x3c,0x38,0x34,
  0x2e,0x28,0x25,0x22,0x1f,0x1d,0x1c,0x1a,
  0x16,0x13,0x11,0x0f,0x0d,0x0b,0x09,0x08,
  0x07,0x06,0x05,0x04,0x03,0x02,0x01,0x00
};

void setup() {
  // put your setup code here, to run once:
  Wire.begin();
  Wire.setClock(400000);//I2C 400kHz
  // pinMode(4,OUTPUT);//SDB
  // digitalWrite(4,HIGH);//SDB_HIGH
  Init_FL3206();
}

void loop() {
  // put your main code here, to run repeatedly:
  IS31FL3206_mode1();//breath mode
}

void IS_IIC_WriteByte(uint8_t Dev_Add,uint8_t Reg_Add,uint8_t Reg_Dat)
{
  Wire.beginTransmission(Dev_Add/2);
  Wire.write(Reg_Add); // sends regaddress

```