

36 CHANNELS LED DRIVER EVALUATION BOARD GUIDE

DESCRIPTION

IS31FL3237 is an LED driver with 36 constant current channels. Each channel can be pulse width modulated (PWM) by 16 bits for smooth LED brightness control. In addition, each channel has an 8-bit output current control register which allows fine tuning the current for rich RGB color mixing, e.g., a pure white color LED application. The maximum output current of each channel is designed to be 38mA, which can be adjusted by one 8-bit global control register. Proprietary programmable algorithms are used in IS31FL3237 to minimize audible noise caused by the MLCC decoupling capacitor. All registers can be programmed via a high speed I2C (1MHz).

FEATURES

- 2.7V to 5.5V VCC supply
- Pin to pin with IS31FL3236/IS31FL3236A (QFN-44, 5mm×5mm)
- 1MHz I2C interface, automatic address increment function with readout function
- Four selectable I2C addresses
- Modulate LED brightness with 256/1024/4096/65536 steps PWM method
- Modulate LED DC current with 256 method
- Global 256 analog global current control
- PWM frequency selectable
- Open short detect function
- Temperature detect function
- Spread spectrum
- QFN-44 (5mm×5mm) package

QUICK START



Figure 1: Photo of IS31FL3237 Evaluation Board

RECOMMENDED EQUIPMENT

- 5.0V, 2A power supply

ABSOLUTE MAXIMUM RATINGS

- ≤ 5.5V power supply

Caution: Do not exceed the conditions listed above, otherwise the board will be damaged.

PROCEDURE

The IS31FL3237 evaluation board is fully assembled and tested. Follow the steps listed below to verify board operation.

Caution: Do not turn on the power supply until all connections are completed.

- 1) Connect the ground terminal of the power supply to the GND and the positive terminal to the VCC. Or connect the DC power to the connector (DC IN) (From version V01C the DC in is replaced by a Micro-USB power in.).
- 2) Turn on the power supply and pay attention to the supply current. If the current exceeds 1.2A, please check for circuit fault.
- 3) Enter the desired mode of display by toggling the MODE button.

ORDERING INFORMATION

Part No.	Temperature Range	Package
IS31FL3237-QFLS4-EB	-40°C to +125°C (Industrial)	QFN-44, Lead-free

Table 1: Ordering Information

For pricing, delivery, and ordering information, please contact Lumissil's analog marketing team at analog@Lumissil.com or (408) 969-6600.

36 CHANNELS LED DRIVER EVALUATION BOARD GUIDE

EVALUATION BOARD OPERATION

The IS31FL3237 evaluation board has six display modes. Press MODE button to switch configurations.

- 1) (Default mode) The 12 RGB LEDs in the middle of the board show a color changing light bar moving pattern.
- 2) Two groups of blue LED on above display a tailing effect move from right to left.
- 3) Two groups of blue LED on above display a tailing effect move in opposite directions.
- 4) Blue LED on above perform timer display.
- 5) Two groups of blue LED on above flash together from two sides to middle and then turn off slowly from both sides to middle.
- 6) The blue LEDs on above are put into four '8' digits and to show a twist effect.

Note: IS31FL3237 solely controls the FxLED function on the evaluation board.

SOFTWARE SUPPORT

JP1 default setting is close circuit. If it is set to open, the on-board MCU will stop working. The I2C pins and SDB pin are set to High Impedance. External I2C and SDB signals can be connected to TP4 to control the IS31FL3237 LED driver.

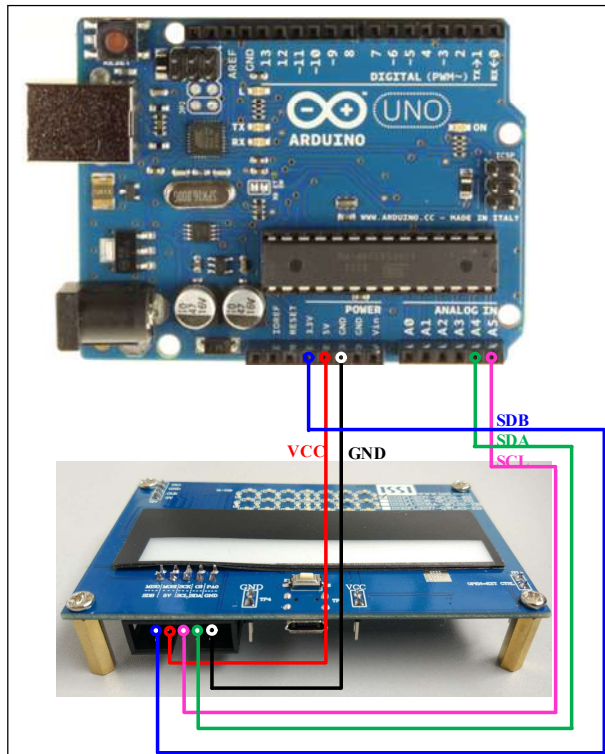

Figure 2: Photo of Arduino UNO connected to Evaluation Board

The steps listed below are an example using the Arduino for external control.

The Arduino hardware consists of an Atmel microcontroller with a bootloader allowing quick firmware updates. First download the latest Arduino Integrated Development Environment IDE (1.6.12 or greater) from www.arduino.cc/en/Main/Software. Also download the Wire.h library from www.arduino.cc/en/reference/wire and verify that pgmspace.h is in the directory ...program Files(x86)/Arduino/hardware/tools/avr/avr/include/avr/. Then download the latest IS31FL3237 test firmware (sketch) from the Lumissil website <http://www.lumissil.com/products/led-driver/fxled>.

- 1) Open JP1.
- 2) Connect the 5 pins from Arduino board to IS31FL3237 EVB:
 - a) Arduino 5V pin to IS31FL3237 EVB VCC.
 - b) Arduino GND to IS31FL3237 EVB GND.
 - c) Arduino SDA (A4) to IS31FL3237 EVB SDA.
 - d) Arduino SCL (A5) to IS31FL3237 EVB SCL.
 - e) If Arduino use 3.3V MCU VCC, connect 3.3V to IS31FL3237 EVB SDB, if Arduino use 5.0V MCU VCC, connect 5.0V to EVB SDB.
(Arduino UNO is 5.0V, so SDB=5.0V)
- 3) Use the test code in appendix I or download the test firmware (sketch) from the Lumissil website, a .txt file and copy the code to Arduino IDE, compile and upload to Arduino.
- 4) Run the Arduino code and the initial mode will change the Blue LED brightness every second. Note: the white color LEDs cannot be controlled when the onboard STM32F103C8T6 is disabled. (Some early board we provided is still controlling the single color LED, if want to switch between single color LED and RGB, remove the U4 and connect the VCC to the LED+)

Please refer to the datasheet to get more information about IS31FL3237.

36 CHANNELS LED DRIVER EVALUATION BOARD GUIDE

A Division of **LSI**

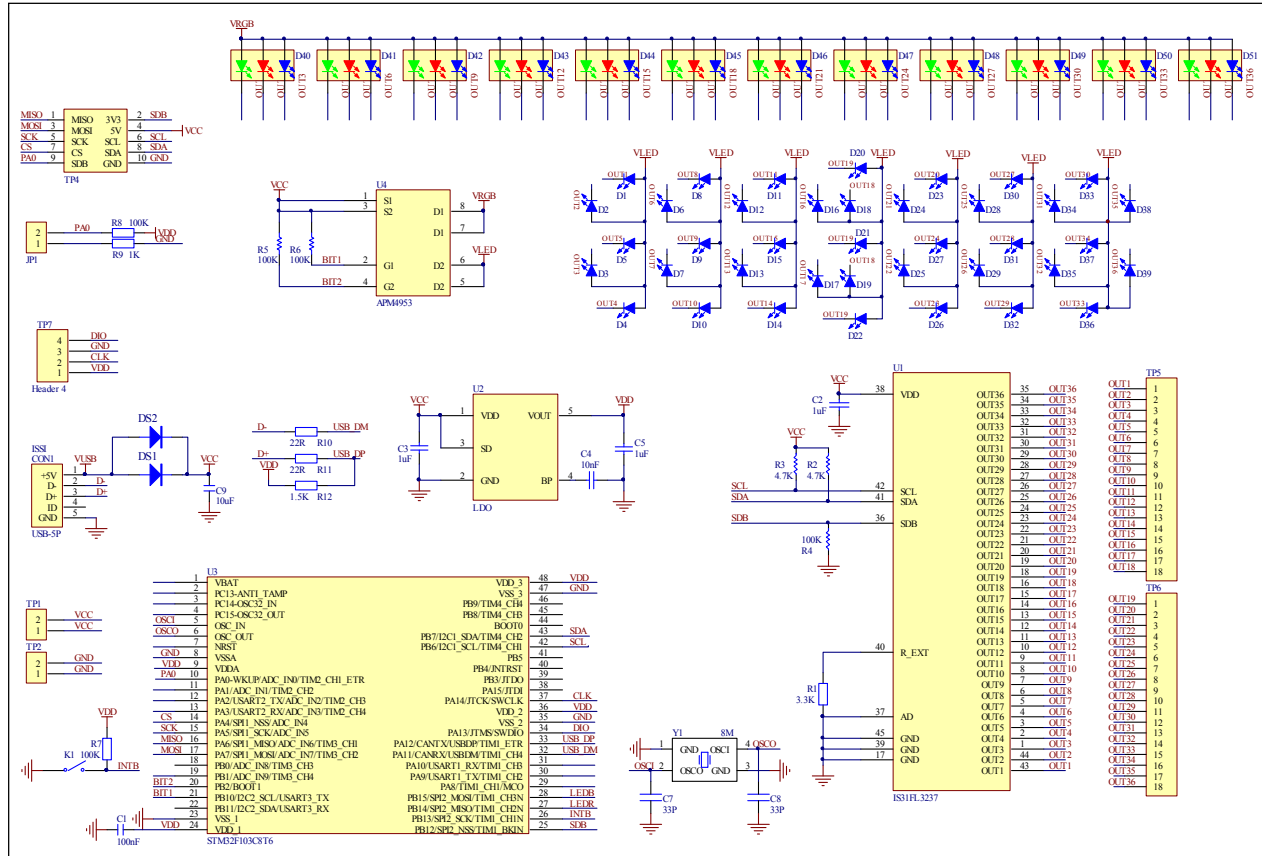

Figure 3: IS31FL3237 Application Schematic

36 CHANNELS LED DRIVER EVALUATION BOARD GUIDE

BILL OF MATERIALS

Name	Symbol	Description	Qty	Supplier	Part No.
LED Driver	U1	36CH FxLED Driver	1	Lumissil	IS31FL3237
LDO	U2	Low-dropout Regulator	1	PAM	PAM3101
MCU	U3	Microcontroller	1	STM	STM32F103C8T6
PMOS	U4	Dual PMOS	1	ANPEC	APM4953
Crystal	Y1	Crystal, 8MHz	1	JB	HC-49S
Diode	D1~D39	Diode, LED Blue, SMD	39	Everlight	19-217/BHC-ZL1M2RY/3T
Diode	D40~D51	Diode, LED RGB, SMD	12	Everlight	99-235/RSGBB7C-A22/2D or 99-235/RGBC/TR8
Diode	DS1, DS2	Diode, SMD	2	DIODES	DFLS240
Resistor	R1	RES,3.3k,1/16W,±5%,SMD	1	Yageo	RC0603JR-073K3L
Resistor	R2~R3	RES,4.7k,1/16W,±5%,SMD	2	Yageo	RC0603JR-074K7L
Resistor	R4~R8	RES,100k,1/16W,±5%,SMD	5	Yageo	RC0603JR-07100KL
Resistor	R9	RES,1k,1/16W,±5%,SMD	1	Yageo	RC0603JR-071KL
Resistor	R10, R11	RES,22R,1/16W,±5%,SMD	1	Yageo	RC0603JR-0722RL
Capacitor	C1	CAP,100nF,16V,±20%,SMD	1	Yageo	CC0603KKX7R9BB104
Capacitor	C2, C3, C5	CAP,1µF,16V,±20%,SMD	3	Yageo	CC0603KKX7R9BB105
Capacitor	C4	CAP,10nF,16V,±20%,SMD	1	Yageo	CC0603KKX7R9BB103
Capacitor	C7, C8	CAP,33pF,16V,±20%,SMD	2	Yageo	CC0603KKX7R9BB330
Capacitor	C9	CAP,10µF,16V,±20%,SMD	1	Yageo	CC0603KKX7R9BB106
Button	K1	Button SMD	1		

Bill of Materials, refer to Figure 3 above.

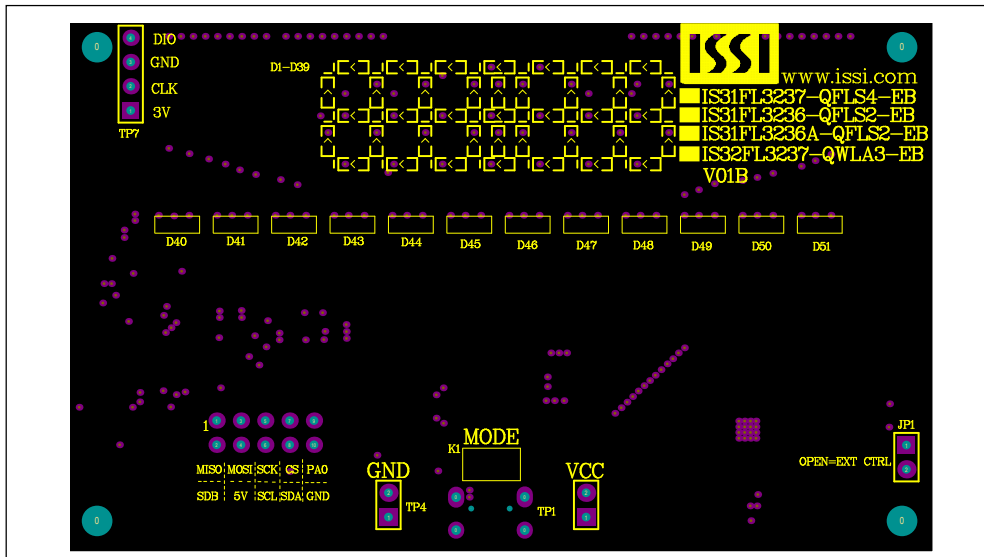

Figure 4: Board Component Placement Guide - Top Layer

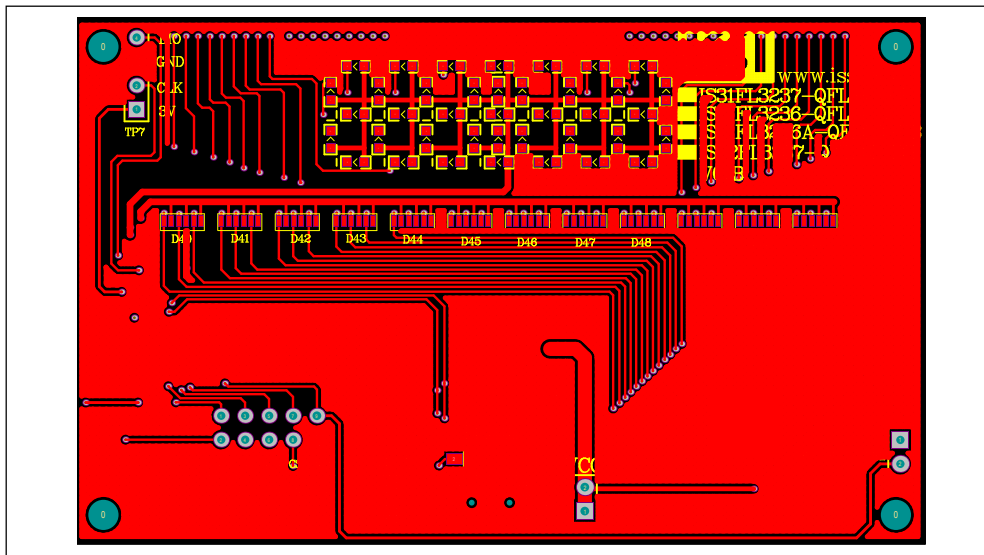

Figure 5: Board PCB Layout - Top Layer

36 CHANNELS LED DRIVER EVALUATION BOARD GUIDE

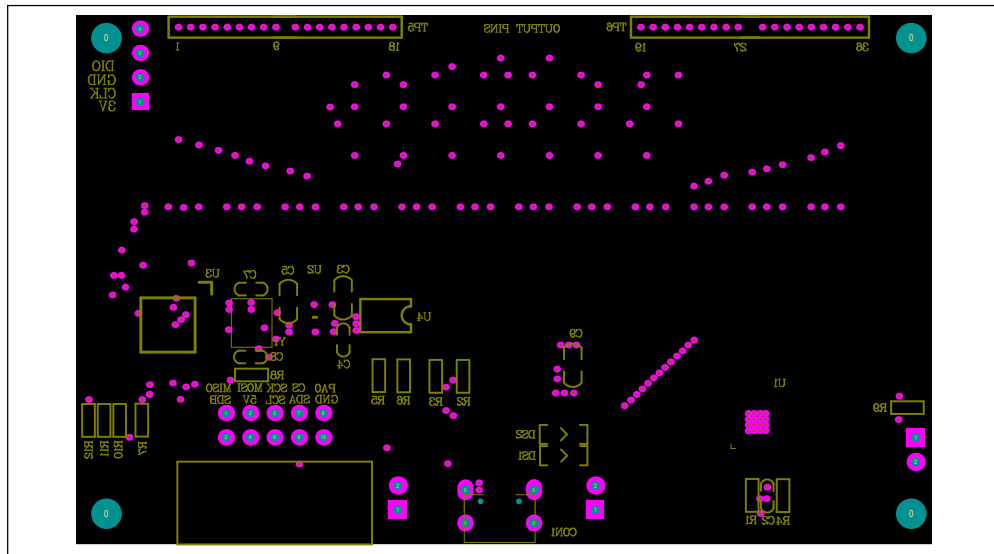

Figure 6: Board Component Placement Guide - Bottom Layer

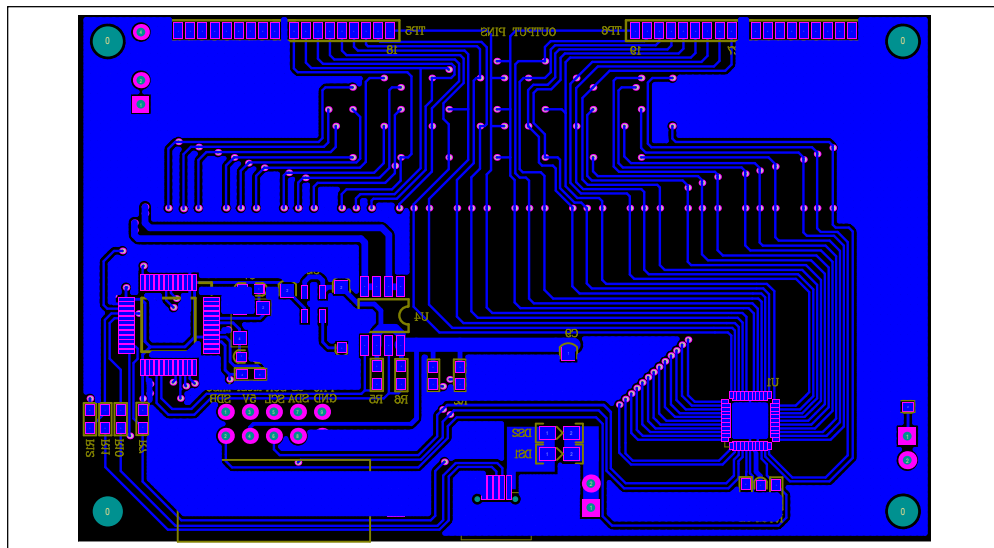

Figure 7: Board PCB Layout - Bottom Layer

36 CHANNELS LED DRIVER EVALUATION BOARD GUIDE

REVISION HISTORY

Revision	Detail Information	Data
A	Initial Release	2018.04.10
B	Update the BOM	2021.05.08
C	Update the Arduino Code	2021.08.31