

16-CHANNEL COLOR LED DRIVER

DESCRIPTION

The IS31FL3726A is a serial shift-register-plus latch-type LED driver. It is comprised of 16 constant-current open drain sinks designed for driving common anode LEDs. The output current value can be set from 5mA to 60mA by using an external resistor.

As a result, all outputs will have virtually the same current levels.

This driver incorporates 16 constant current outputs, a 16-bit shift register, a 16-bit latch and a 16-bit AND-gate circuit.

The IS31FL3726A is an industry standard serial shift-register-plus latch-type LED driver operating from a 3V to 5V supply. It is comprised of 16 constant-current open drain sinks designed for driving common anode LEDs. The output current value can be set from 5mA to 60mA by using an external resistor. As a result, all outputs will have virtually the same current levels. This driver uses a high-speed 4-wire serial interface of up to 30MHz to drive 16 constant current outputs, a 16-bit shift register, a 16-bit latch and a 16-bit AND-gate circuit. Serial input data appears at the output OUTx channels after 16 clock cycles. Driving the Latch pin will load the 16-bit of shift-register data into the 16-bit output latch to drive the LEDs ON or OFF. The Enable pin can be used as a PWM input to adjust the LED brightness.

FEATURES

- Output current capability and number of outputs: 60mA × 16 outputs
- Constant current range: 5mA to 60mA
 $I_{OUT_MAX} = 45mA @ V_{CC} = 3V$
 $I_{OUT_MAX} = 60mA @ V_{CC} = 3.3V$
- For anode-common LEDs
- Power supply voltage range, $V_{CC} = 3.0V$ to 5.5V
- Serial and parallel data transfer rate: 30MHz (Max. cascade connection)
- Operating temperature range, $T_A = -40^{\circ}C \sim +125^{\circ}C$
- Package: QFN-24 (4mm×4mm), SSOP-24 and eTSSOP-24
- Current accuracy (All output on)
 - Bit to bit: < ±5%.
 - Device to device: < ±7%.

ORDERING INFORMATION

Part No.	Temperature Range	Package
IS31FL3726A-QFLS4-EB	-40°C to +125°C (Industrial)	QFN-24, Lead-free

Table 1: Ordering Information

For pricing, delivery, and ordering information, please contact Lumissil's analog marketing team at analog@Lumissil.com or (408) 969-6600.

QUICK START

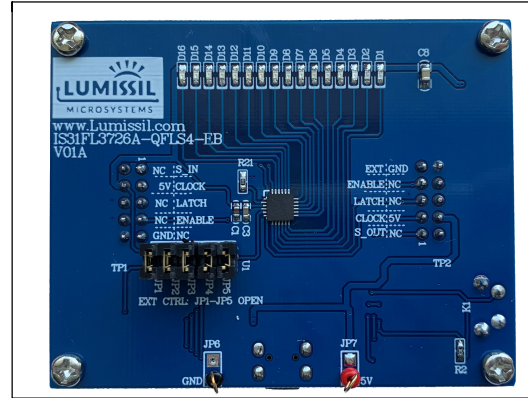

Figure 1: Photo of IS31FL3726A Evaluation Board

RECOMMENDED EQUIPMENT

- 5.0V, 2A power supply

ABSOLUTE MAXIMUM RATINGS

- ≤ 5.5V power supply

Caution: Do not exceed the conditions listed above, otherwise the board will be damaged.

PROCEDURE

The IS31FL3726A evaluation board is fully assembled and tested. Follow the steps listed below to verify board operation.

Caution: Do not turn on the power supply until all connections are completed.

- 1) Short JP1/JP2/JP3/JP4/JP5 in TP1.
- 2) Connect the 5V DC power to VCC (JP7) / GND (JP6), or plug in the USB power input to micro-USB (CON1).
- 3) Turn on the power supply/Plug in the Micro USB. Pay attention to the supply current. If the current exceeds 1A, please check for circuit fault.

16-CHANNEL COLOR LED DRIVER

EVALUATION BOARD OPERATION

The IS31FL3726A evaluation board has three animation display modes. Toggling the MODE button (K1) can switch the modes.

- 1) All LEDs light up
- 2) Four LEDs swing
- 3) LEDs Scroll to left
- 4) Police lights flashing

Note: IS31FL3726A solely controls the FxLED function on the evaluation board.

SOFTWARE SUPPORT

JP1/JP2/JP3/JP4/JP5 in TP1 default setting is closed (jumper on). If it is open (no jumper), the on-board MCU will configure its own S_IN/CLOCK/LATCH/ENABLE pins to High Impedance status so an external source can driver the serial and parallel data transfer signals to control the IS31FL3726A LED driver.

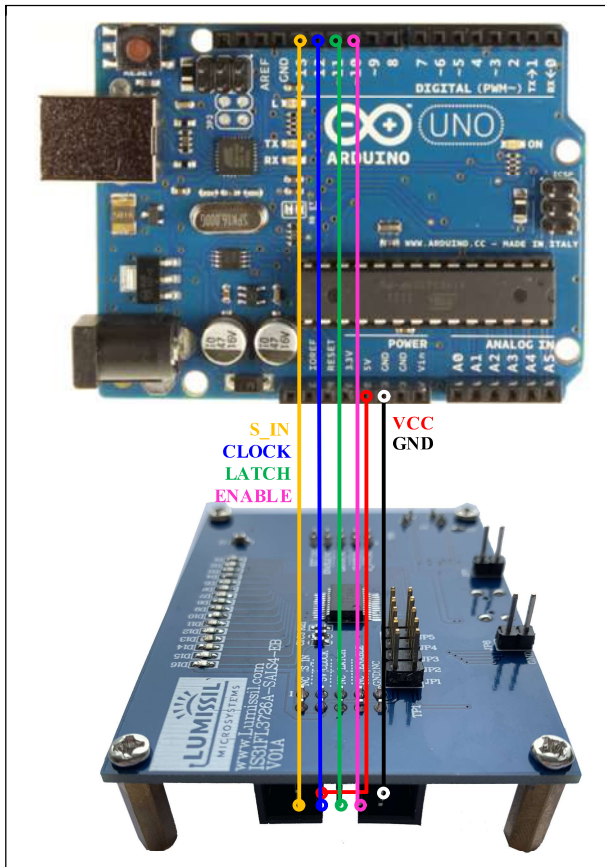

Figure 2: Photo of Arduino UNO connected to Evaluation Board

The steps listed below is an example of using the Arduino for external control.

The Arduino hardware consists of an Atmel microcontroller with a bootloader allowing quick firmware updates. First download the latest Arduino Integrated Development Environment IDE (1.6.12 or greater) from www.arduino.cc/en/Main/Software. Also download the Wire.h library from www.arduino.cc/en/reference/wire and verify that pgmspace.h is in the directory ...program Files(x86)/Arduino/hardware/tools/avr/avr/include/avr/. Then download the latest IS31FL3726A test firmware (sketch) from the Lumissil website <http://www.lumissil.com/products/led-driver/fxled>.

- 1) Open JP1/JP2/JP3/JP4/JP5 in TP1.
- 2) Connect the 6 pins from Arduino board to IS31FL3726A EVB:
 - a) Arduino 5V pin to IS31FL3726A EVB PVCC.
 - b) Arduino GND to IS31FL3726A EVB GND.
 - c) Arduino S_IN (13) to IS31FL3726A EVB S_IN.
 - d) Arduino CLOCK (12) to IS31FL3726A EVB CLOCK.
 - e) Arduino LATCH (11) to IS31FL3726A EVB LATCH.
 - f) Arduino ENABLE (10) to IS31FL3726A EVB ENABLE.
- 3) Use the test code in appendix I or download the test firmware (sketch) from the Lumissil website, a .txt file and copy the code to Arduino IDE, compile and upload to Arduino.
- 4) Run the Arduino code as appendix I.

Please refer to the datasheet to get more information about IS31FL3726A.

16-CHANNEL COLOR LED DRIVER

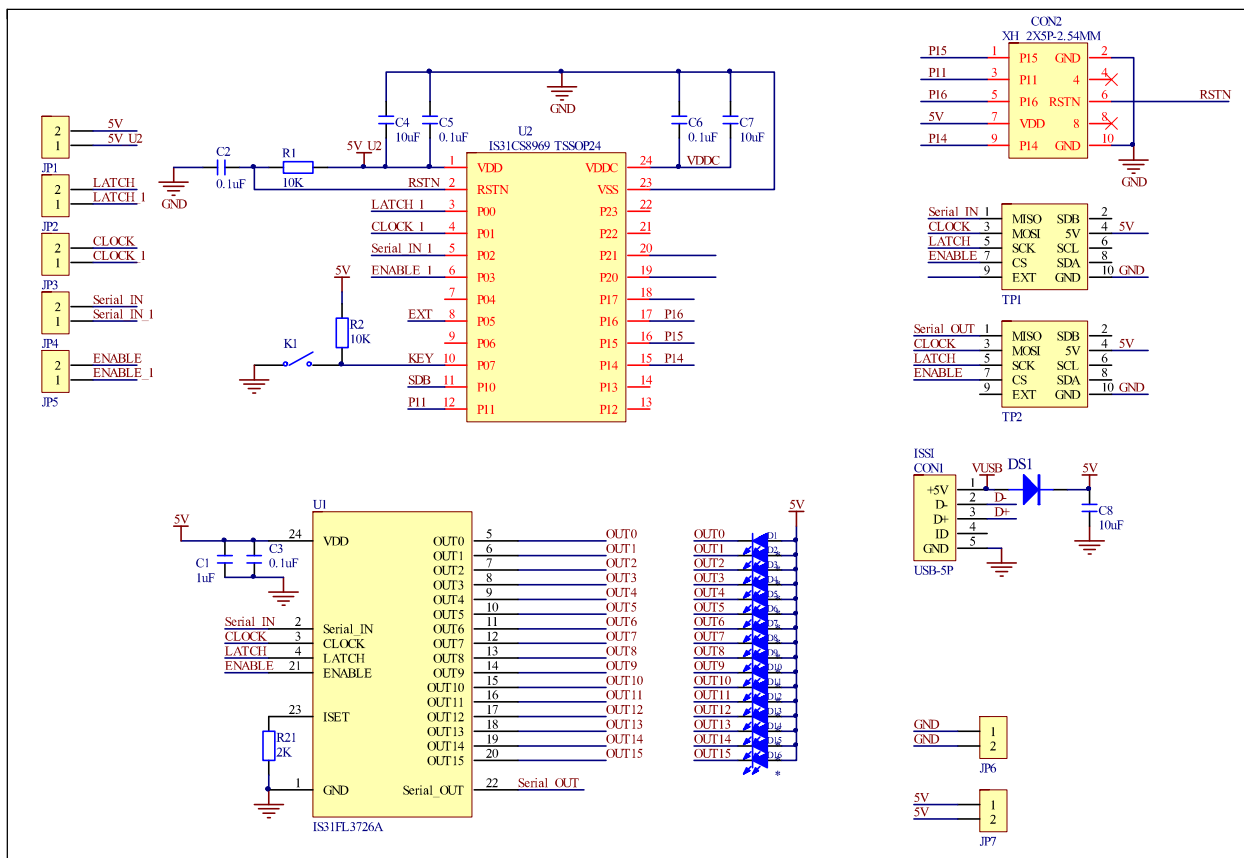

Figure 3: IS31FL3726A Application Schematic

16-CHANNEL COLOR LED DRIVER

BILL OF MATERIALS

Name	Symbol	Description	Qty	Supplier	Part No.
LED Driver	U1	16-CH Color LED Driver	1	Lumissil	IS31FL3726A
MCU	U2	Microcontroller	1	Lumissil	IS31CS8969
Diode	DS1	Diode, SMD	1	DIODES	DFLS240
LED	D1~D16	Blue LED, SMD	16	Everlight	9-217/BHC-ZL1M2RY/3T
Resistor	R1,R2	RES,10k,1/16W,±5%,SMD	2	Yageo	RC0603JR-0710KL
Resistor	R21	RES,2k,1/16W,±5%,SMD	1	Yageo	RC0603JR-072KL
Capacitor	C1	CAP,1µF,16V,±20%,SMD	1	Yageo	CC0603KRX7R7BB105
Capacitor	C2,C3,C5,C6	CAP,0.1µF,16V,±20%,SMD	4	Yageo	CC0603MRX7R7BB104
Capacitor	C4,C7	CAP,10µF,16V, ±20%,SMD	2	Yageo	CC0603KRX5R7BB106
Capacitor	C8	CAP,10µF,16V, ±20%,SMD	1	Yageo	CC0805MKX5R7BB106
Button	K1	Button SMD	1		

Bill of Materials, refer to Figure 3 above.

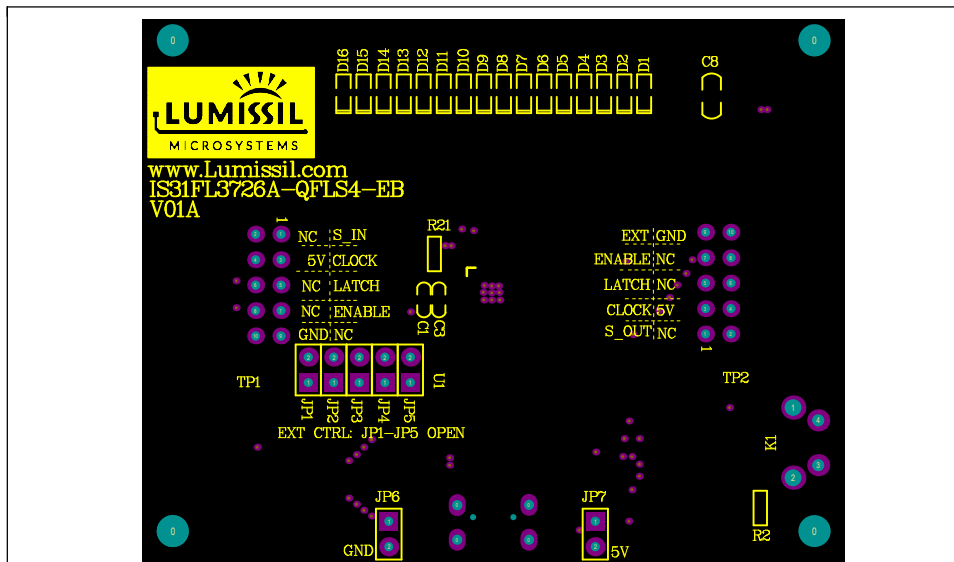

Figure 5: Board Component Placement Guide - Top Layer

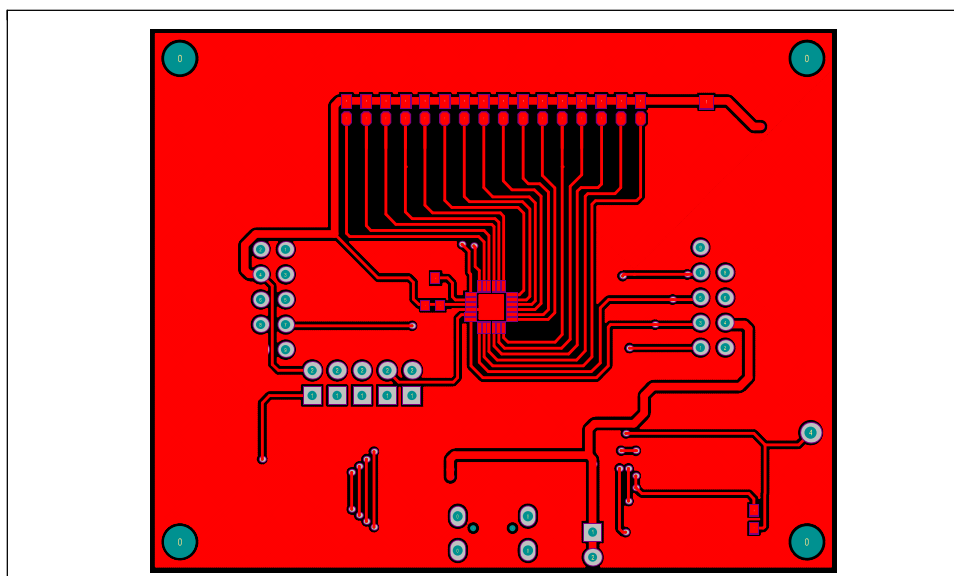

Figure 6: Board PCB Layout - Top Layer

16-CHANNEL COLOR LED DRIVER

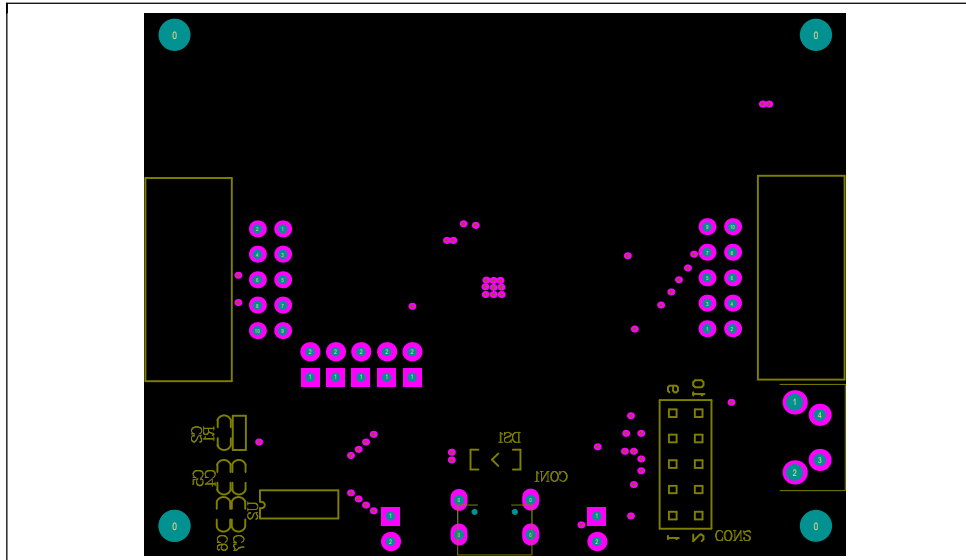

Figure 7: Board Component Placement Guide - Bottom Layer

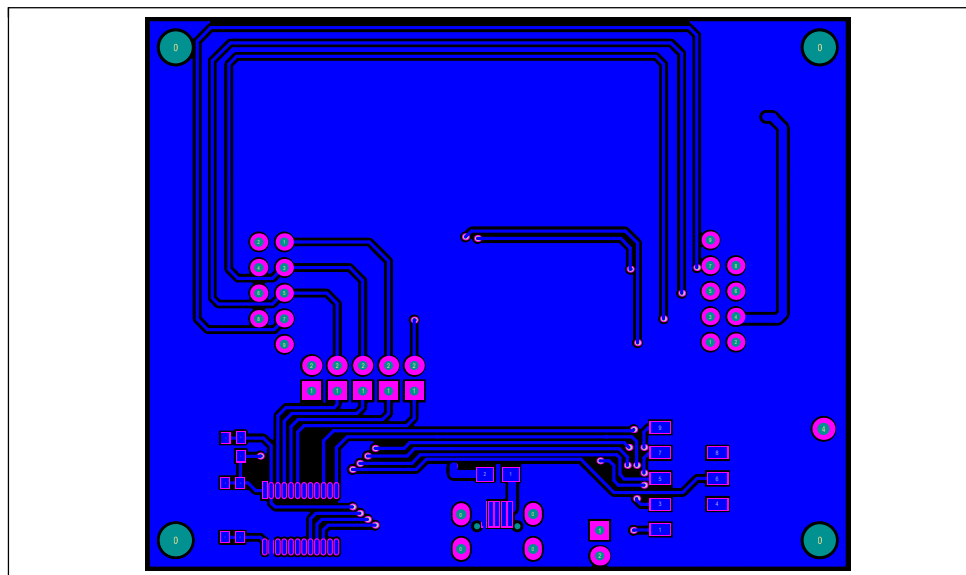

Figure 8: Board PCB Layout - Bottom Layer

16-CHANNEL COLOR LED DRIVER

REVISION HISTORY

Revision	Detail Information	Date
B	Add QFN-24 Package	2020.06.02

Copyright © 2020 Lumissil Microsystems. All rights reserved. Lumissil Microsystems reserves the right to make changes to this specification and its products at any time without notice. Lumissil Microsystems assumes no liability arising out of the application or use of any information, products or services described herein. Customers are advised to obtain the latest version of this device specification before relying on any published information and before placing orders for products.

Lumissil Microsystems does not recommend the use of any of its products in life support applications where the failure or malfunction of the product can reasonably be expected to cause failure of the life support system or to significantly affect its safety or effectiveness. Products are not authorized for use in such applications unless Lumissil Microsystems receives written assurance to its satisfaction, that:

- a.) the risk of injury or damage has been minimized;
- b.) the user assume all such risks; and
- c.) potential liability of Lumissil Microsystems is adequately protected under the circumstances

16-CHANNEL COLOR LED DRIVER

APPENDIX I : IS31FL3726A Arduino Test Code V01A

```
#include<Wire.h>
#include<avr/pgmspace.h>

#define S_IN_HIGH digitalWrite(13,HIGH);
#define S_IN_LOW digitalWrite(13,LOW);
#define CLK_HIGH digitalWrite(12,HIGH);
#define CLK_LOW digitalWrite(12,LOW);
#define LATCH_HIGH digitalWrite(11,HIGH);
#define LATCH_LOW digitalWrite(11,LOW);
#define ENABLE_HIGH digitalWrite(10,HIGH);
#define ENABLE_LOW digitalWrite(10,LOW);

void setup() {

    // put your setup code here, to run once:
    Wire.begin();
    Wire.setClock(400000);//I2C 400kHz
    pinMode(13,OUTPUT);//S_IN
    pinMode(12,OUTPUT);//CLK
    pinMode(11,OUTPUT);//LATCH
    pinMode(10,OUTPUT);//ENABLE
    digitalWrite(13,HIGH);//S_IN_HIGH
    digitalWrite(12,HIGH);//CLK_HIGH
    digitalWrite(11,HIGH);//LATCH_HIGH
    digitalWrite(10,HIGH);//ENABLE_HIGH
    //delay(100); //keep 0.5s
    Init_FL3726A();
}

void loop() {
    // put your main code here, to run repeatedly:
    // delay(50);
    IS31FL3726A_mode1();//
}

void SPD_WriteByte(uint8_t HighByte,uint8_t LowByte)
{
    int i;
    int idate;

    //Delay10ms(10);
    idate=(HighByte<<8)|LowByte;
    for(i=0;i<16;i++)
```

16-CHANNEL COLOR LED DRIVER

```

{
  if (idate&0x8000)
  {
    digitalWrite(13,HIGH);//S_IN_HIGH;
    delay(1);
  }
  else
  {
    digitalWrite(13,LOW);//S_IN_LOW;
    delay(1);
  }
  delay(1);
  digitalWrite(12,HIGH);//CLK_HIGH;
  delay(1);
  digitalWrite(12,LOW);//CLK_LOW;
  idate=idate<<1;

}
delay(1);
digitalWrite(13,HIGH);// S_IN_HIGH;//
delay(1);
digitalWrite(11,HIGH);//LATCH_HIGH;//
delay(1);
digitalWrite(11,LOW);//LATCH_LOW;//
delay(1);
digitalWrite(10,LOW);//ENABLE_LOW;//

}

void Init_FL3726A(void)
{
  SPD_WriteByte(0x00,0x00);
}

void IS31FL3726A_mode1(void)
{
  SPD_WriteByte(0x80,0X80);
  delay(100);
  SPD_WriteByte(0x40,0X40);
  delay(100);
  SPD_WriteByte(0x20,0X20);
  delay(100);
  SPD_WriteByte(0x10,0X10);
  delay(100);
  SPD_WriteByte(0x08,0X08);
}

```