

IS32LT3124A/B/C/D/E/F QUAD CHANNEL LINEAR LED DRIVER

DESCRIPTION

The IS32LT3124 is a linear programmable current regulator consisting of 4 output channels capable of up to 150mA each. Individual external resistors set the maximum current level for each channel. The outputs can be combined to provide a higher current drive capability up to 600mA (Max.).

The IS32LT3124 features Dynamic Headroom Control (DHC) with an optional external PMOS FET to minimize IC thermal stress when the supply voltage exceeds the LED string forward voltage. It includes two modes for different output power: Shunt Regulator mode and Series Regulator mode. It can operate with power supply modulation (PSM) for applications requiring dimming without use of the EN pin.

For added system reliability, the IS32LT3124 integrates fault detection circuitry for open/short circuit and over temperature conditions. The fault pins (FLT B) can all be tied together to disable the device and other IS32LT3124 devices on the same parallel circuit.

To handle all these different fault detection and reporting features, the IS32LT3124 has six different versions: A, B, C, D, E and F. All of them can support the above features. See table 1 for the major difference. In IS32LT3124A/B/D/E, if any fault condition occurs, all output currents will be disabled. In IS32LT3124B/C/E/F, individual ISET pin for each LED channel is redefined as individual PWM dimming control, thus ISET open detection function is removed. The EN pin of IS32LT3124B/C/E/F is featured as the enable signal of the internal fault reporting block. See Table 4 for complete fault listing.

The IS32LT3124 is targeted at the automotive market such as interior accent lighting and exterior tail lighting. It is offered in a thermally enhanced eTSSOP-16 package.

QUICK START

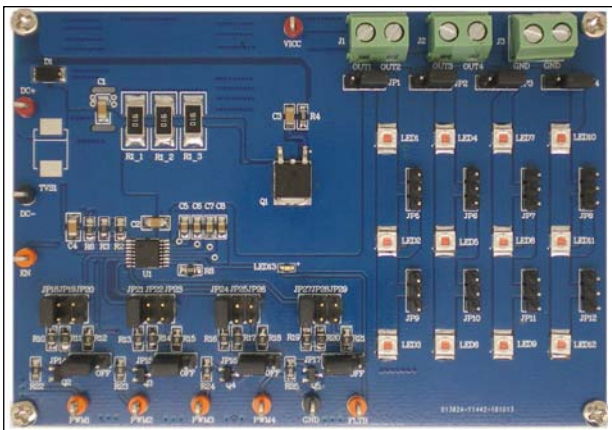

Figure 1: Photo of IS32LT3124 Evaluation Board

FEATURES

- 5.0V to 28V input supply voltage range
 - Withstand 42V load dump
- Four output channels can source up to 150mA each
 - Four current set resistors
 - $\pm 5\%$ output current accuracy
 - Low dropout voltage of 1V (Max.) at 100mA
 - Combined for higher current capability with same current accuracy
- PWM dimming and shutdown control input
 - 100Hz~300Hz power supply modulation (PSM)
 - 100Hz~1kHz individual dimming via resistors of ISETx pins (IS32LT3124B/C/E/F only)
- Optional Dynamic Headroom Control (DHC) with an external PMOS FET to minimize IC thermal stress
 - Shunt regulator mode for heavy load
 - Series regulator mode for light load
- Additional external UVLO (Under Voltage Lockout Threshold) is programmable via EN pin (IS32LT3124A/D only)
- Fault protection and reporting
 - Externally enable/disable fault reporting (IS32LT3124B/C/E/F only)
 - Programmable fault reporting output delay time
 - Fault condition disables all output (IS32LT3124A/B/D/E only)
 - Parallel fault connection (one-fail-all-fail)
 - LED string open/short
 - Single LED short (Conditional, IS32LT3124B/C/D only)
 - ISET pin short
 - ISET pin open (IS32LT3124A/D only)
 - Over temperature
- AEC-Q100 Qualified
- Operating temperature range ($-40^{\circ}\text{C} \sim +125^{\circ}\text{C}$)

RECOMMENDED EQUIPMENT

- 12V, 1A DC power supply

ABSOLUTE MAXIMUM RATINGS

- $\leq 28\text{V}$ power supply

Caution: Do not exceed the conditions listed above, otherwise the board will be damaged.

PROCEDURE

The IS32LT3124 evaluation board is fully assembled and tested. Follow the steps listed below to verify board operation.

Caution: Do not turn on the power supply until all connections are completed.

IS32LT3124A/B/C/D/E/F QUAD CHANNEL LINEAR LED DRIVER

- 1) Connect the negative terminal of the power supply to the DC- and the positive terminal to the DC+.
- 2) The output current of each channel is individually set by its corresponding reference resistor (R_{ISETx}). There are three current level setting as below:

Table 1 Current Setting

| Close Jumper J18,J21,J24,J27 (39kΩ) | Close Jumper J19,J22,J25,J28 (20kΩ) | Close Jumper J20,J23,J26,J29 (13kΩ) |
|---|---|---|
| $I_{OUT1}=50mA$ | $I_{OUT1}=100mA$ | $I_{OUT1}=150mA$ |
| $I_{OUT2}=50mA$ | $I_{OUT2}=100mA$ | $I_{OUT2}=150mA$ |
| $I_{OUT3}=50mA$ | $I_{OUT3}=100mA$ | $I_{OUT3}=150mA$ |
| $I_{OUT4}=50mA$ | $I_{OUT4}=100mA$ | $I_{OUT4}=150mA$ |

Note: Each output current is set by a single resistor. If more than one resistor for a channel is selected, the output current will exceed the IS32LT3124 max current and trigger its output current limit.

The evaluation board default is set at the Shunt Regulator mode. The default total output current is 600mA and the shunt resistor value is set at 15ohm (6pcs 91ohm resistors in parallel value, R1_1~R1_6). Since the shunt resistor R1 sustains plenty of power dissipation at high input voltage, several large package resistors in parallel should be used for R1. The shunt resistor R1 value should be fine-tuned if the output current is changed. The shunt resistor value can be calculated by:

$$R1 = (V_{TR} - V_{OUT_MAX} - V_{HR}) / I_{TOT}$$

V_{TR} is the transition voltage, recommend to choose V_{TR} at 16V. V_{OUT_MAX} is the maximum voltage of four OUTx pins. V_{HR} is the headroom voltage, default is set at 1.0V. I_{TOT} is the total current of all output channels. For more detail please refer to the IS32LT3124 datasheet, and download the Excel spread sheet calculator from

- 3) Lumissil website, to calculate the power dissipation of the key components: shunt resistor R1, IS32LT3124 and PMOS FET.
- 3) Default EN pins via R3 (82kΩ) resistor to VCC and R2 (15kΩ) resistor to GND. If apply a PWM signal to EN pins (only for IS32LT3124A/D), please remove resistor R3, otherwise the PWM source may be damaged.
- 4) JP14~17 is option of individual PWM dimming (only for IS32LT3124B/C/E/F). Close the jumpers to 'ON' side to disable the PWM dimming. Close the jumpers to 'OFF' side to enable PWM dimming and apply external PWM signals to PWM1~PWM4 terminals for dimming.
- 5) JP1, JP2, JP3, JP4 are used to connect the IS32LT3124A/B/C/D/E/F output to the onboard LED strings (LED1~LED12). JP1, JP2, JP3, JP4 pins 1 is connected to VCC pin, and pins 3 is connected to the onboard LED strings. Remove the corresponding jumper JP1, JP2, JP3, JP4 to disable the onboard LED string, and use the green terminal blocks to connect external LED strings.

Note: Connecting external LED strings without removing JP1~JP4 jumpers header will drive both onboard and external LED strings in parallel resulting in lower current drive to the LED string.
- 6) The onboard LED strings can be adjusted from 1 to 3 LEDs by using jumper headers JP5~JP12. Connecting the Jumper to pins 2-3 disables the corresponding LED. To enable all the LED strings, connect jumpers to pins 1-2 of JP5~JP12 or remove.
- 7) R9, R26, C9, ZD1 and LED13 are used for fault reporting indicator.

Note: This circuit is not necessary for real application.
- 8) Turn on the power supply and the LEDs will be lighted up.

ORDERING INFORMATION

| Order Part No. | Package | QTY/Reel |
|---------------------|----------------------|----------|
| IS32LT3124A-ZLA3-EB | eTSSOP-16, Lead-free | 2500 |
| IS32LT3124B-ZLA3-EB | | |
| IS32LT3124C-ZLA3-EB | | |
| IS32LT3124D-ZLA3-EB | | |
| IS32LT3124E-ZLA3-EB | | |
| IS32LT3124F-ZLA3-EB | | |

Table 1: Ordering Information

For pricing, delivery, and ordering information, please contact Lumissil's analog marketing team at analog@Lumissil.com or (408) 969-6600.

IS32LT3124A/B/C/D/E/F QUAD CHANNEL LINEAR LED DRIVER

SCHEMATIC

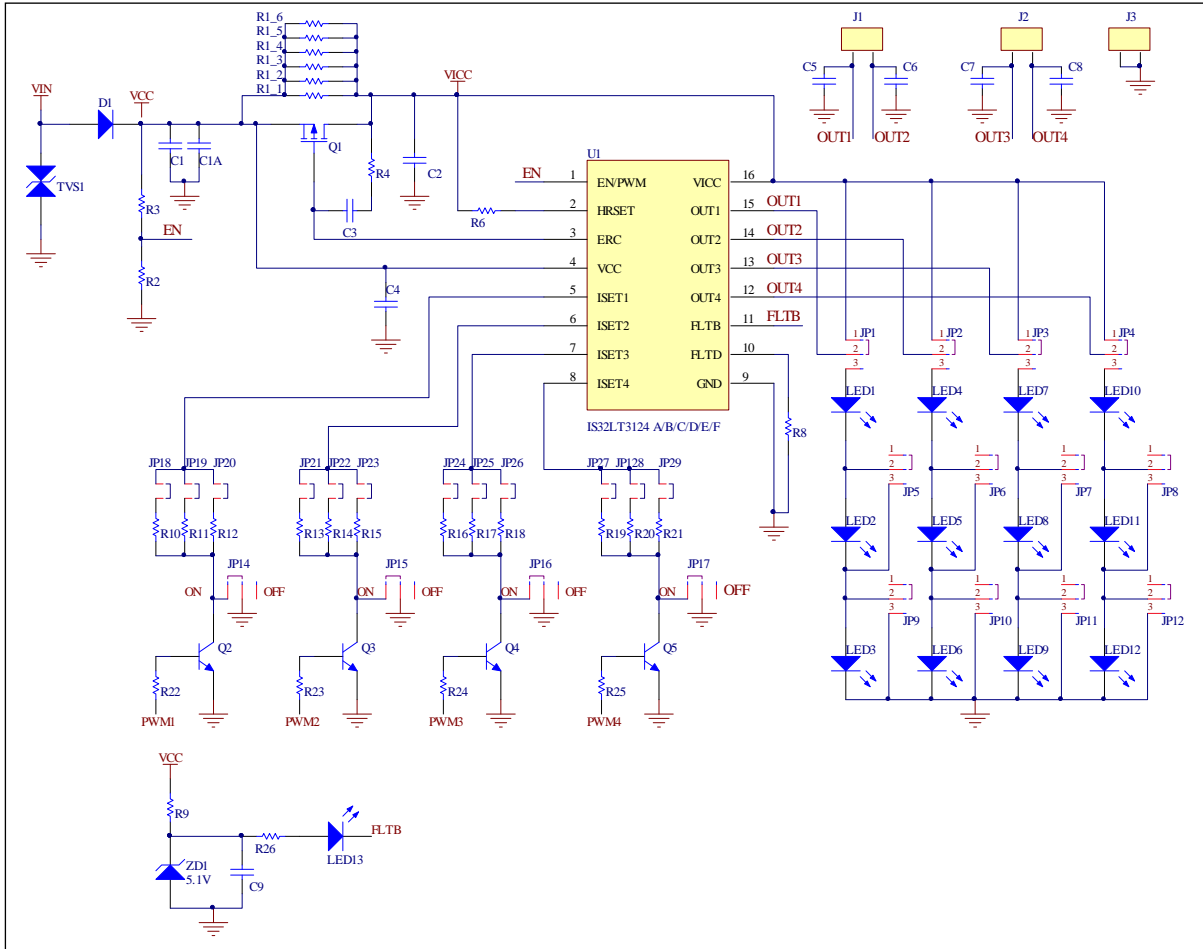

Figure 2: IS32LT3124A/B/C/D/E/F DEMO Schematic

Table 2 Jumper Setting

| Jumper | Options | Settings |
|--------------------------------------|--|---|
| JP1,JP2,JP3,JP4 | Power to the onboard LED strings or external LED strings | Close pin1-2: connect output to VICC Close pin2-3: connect output to onboard LED strings Open: connect the external LED strings to J1~J3 blocks |
| JP5,JP6,JP7,JP8, JP9,JP10,JP11, JP12 | Number of LEDs control | Close pin1-2 or open: enable the corresponding LED Close pin2-3: disable the corresponding LED. |
| JP14,JP15,JP16, JP17 | Individual PWM dimming setting. If need individual PWM dimming (only for IS32LT3124B/C/E/F), please close jumpers to 'OFF' side. | Close Jumper to 'ON': no PWM dimming. Close Jumper to 'OFF': individual PWM dimming |
| JP18~JP29 | Output current setting. | Close jumper to select corresponding resistor. Refer to table 1 for details |
| J1,J2,J3,J4 | External LED string connector | J1:connect external LEDs to out1,out2 J2:connect external LEDs to out3,out4 J3:GND |

IS32LT3124A/B/C/D/E/F QUAD CHANNEL LINEAR LED DRIVER

BILL OF MATERIALS

| Name | Symbol | Description | Qty | Supplier | Part No. |
|------------|---------------------------------|--|-----|-----------|-----------------------|
| LED Driver | U1 | 4CH Constant current LED driver | 1 | Lumissil | IS32LT3124A/B/C/D/E/F |
| Capacitor | C3 | CAP,22nF,50V,±10%,SMD | 1 | Yageo | AC1206KRX7R9BB223 |
| Capacitor | C1,C2,C4 | CAP,100nF,50V,±10%,SMD | 3 | Yageo | AC1206KRX7R9BB104 |
| Capacitor | C5,C6,C7,C8 | CAP,10nF,50V,±10%,SMD | 4 | Yageo | AC0805KRX7R9BB103 |
| | C1A,C9,LED3,LED6, LED9,LED12 | Not Installed | 6 | | |
| Resistor | R1_1~R1_6 | RES,91R,2512,±5%,SMD | 6 | Yageo | AC2512JK-0791RL |
| Resistor | R2 | RES,15k, 0805,±1%,SMD | 1 | Yageo | AC0805FR-0715KL |
| Resistor | R3 | RES,82k, 0805,±1%,SMD | 1 | Yageo | AC0805FR-0782KL |
| Resistor | R4,R8 | RES,0R, 0805,±5%,SMD | 2 | Yageo | AC0805JR-070RL |
| Resistor | R6 | RES,2k, 0805,±1%,SMD | 1 | Yageo | AC0805FR-072KL |
| Resistor | R9 | RES,5.1k, 0805,±5%,SMD | 1 | Yageo | AC0805JR-075K1L |
| Resistor | R10,R13,R16,R19 | RES,39k, 0805,±1%,SMD | 4 | Yageo | AC0805FR-0739KL |
| Resistor | R11,R14,R17,R20 | RES,20k, 0805,±1%,SMD | 4 | Yageo | AC0805FR-0720KL |
| Resistor | R12,R15,R18,R21 | RES,13k, 0805,±1%,SMD | 4 | Yageo | AC0805FR-0713KL |
| Resistor | R22,R23,R24,R25 | RES,1k, 0805,±5%,SMD | 4 | Yageo | AC0805JR-071KL |
| Resistor | R26 | RES,4.7k, 0603,±5%,SMD | 1 | Yageo | AC0603JR-074K7L |
| PMOS | Q1 | PMOS, 60V/12A, | 1 | ONsemi | NTD2955-1G |
| BJT | Q2,Q3,Q4,Q5 | NPN, 40V/200mA, 3904 | 4 | Fairchild | MMBT3904 |
| Schottky | D1 | SS26,2A,60V,SMB | 1 | ONsemi | NRVBSS26T3G |
| Zener | ZD1 | ZMM5.1V,0.5W, LL-34 | 1 | | |
| LED | LED1~LED12 | Yellow LED, 350mA,V _f =2.0V~2.2V | 12 | | |
| LED | LED13 | Red LED,20mA,V _f =1.8V, | 1 | | |
| Headers | JP1~JP12, JP14~JP17 | 3 pin headers | 16 | | |
| Headers | JP18~JP29 | 2 pin headers | 12 | | |

Bill of Materials, refer to Figure 2 above.

IS32LT3124A/B/C/D/E/F QUAD CHANNEL LINEAR LED DRIVER

EVALUATION BOARD OPERATION

OUTPUT CURRENT SETTING

The regulated LED current (up to 150mA) from each channel is individually set by its corresponding reference resistor (R_{ISETx}). The programming resistors may be computed using the following Equation (1):

$$R_{ISET} = \frac{V_{ISET}}{I_{OUT}} \times 2000 \quad (1)$$

($13k\Omega \leq R_{ISET} \leq 200k\Omega$) and $V_{ISET} = 1V$ (Typ.)

It is recommended that R_{ISETx} be a 1% accuracy resistor with good temperature characteristic to ensure stable output current.

The current outputs can be connected in parallel for a combined 600mA or can be left unconnected as required. Several channels combined in parallel will have the same current accuracy as the independent channel.

HEADROOM SETTING

As previously stated, the headroom voltage is set by the resistor R_{HR} from the HRSET and VICC pins:

$$V_{HRSET} = R_{HR} \times \left(\frac{1V}{2000} \right) \quad (2)$$

The IS32LT3124 internally limits the maximum V_{HRSET} to 3.0V (typical) to ensure reasonable thermal on the IS32LT3124. A headroom voltage setting of 1.5V~2.5V is recommended for most application.

To maintain the normal operation of the internal detection circuit and the dynamic head room control, the VICC voltage must be set above 5V, otherwise the DHC circuit will be abnormal and the V_{HR_MIN} cannot be maintained at set value.

$$R_{HR} \times \left(\frac{1V}{2000} \right) + V_{OUT_MAX} > 5V \quad (3)$$

Therefore in low LED string voltage application, e.g. one RED LED with around 2V forward voltage, some appropriate value power resistors in series with LED strings should be used to increase the maximum voltage of four OUTx pins. The power resistor value R_p can be calculated by:

$$\frac{V_{VICC} - V_{OUT_MAX}}{I_{OUT_X}} > R_p > \frac{5V - V_{OUT_MAX}}{I_{OUT_X}} \quad (4)$$

Where, V_{OUT_MAX} is the maximum voltage of four OUTx pins without any power resistor and I_{OUT_X} is the current of this channel.

Note: the approach of adding the series power resistor is only available for IS32LT3124A/E/F versions. The IS32LT3124B/C/D using the series power resistor would falsely trigger short fault protection and latched all outputs off. So IS32LT3124B/C/D only can drive the LED string with the forward voltage $> (V_{SCD_MAX} + V_{SCD_HY})$.

FAULT REPORTING OPERATION

For robust system reliability, the IS32LT3124 integrates the detection circuitry to protect various fault conditions and report the fault by the FLTB pin which can be monitored by an external host. The FLTB pin is internally pulled up to 4.5V by a resistor R_{FLT} and so it can be left floating, or unconnected. The FLTB pin will go low when the device enables fault detection and detects a fault condition such as LED string open, short to GND, thermal shutdown, or ISET pin open/short (refer to Table 4). For IS32LT3124B/C/E/F, the fault detection and actions are always active, however the FLTB reporting is not active until EN pin voltage rise above V_{EN_TH} . For the IS32LT3124A/D, ISET open fault detection is disabled when the voltage of the OUTx pins are not floating or grounded, unused OUTx pins should be tied to VICC for unused purpose.

In PSM dimming application, with a fault condition, the fault reporting will be reset as VCC voltage goes low. So the external fault reporting monitor should check cycle by cycle, and keep at least 100 μ s monitor blanking time after VCC rising up to prevent some spurious fault.

IS32LT3124A/B/C/D/E/F QUAD CHANNEL LINEAR LED DRIVER

Table 4 Different Fault Action of 3 Types

| EN Voltage | Fault Type | Fault Condition | IS32LT3124A/D | | | IS32LT3124B/E | | | IS32LT3124C/F | | | Auto Recovery |
|---------------|-------------------|-----------------------------------|---|----------------|--|------------------------------------|----------------|--|----------------------|----------------|--|--|
| | | | Faulty Channel | Other Channels | FLTB | Faulty Channel | Other Channels | FLTB | Faulty Channel | Other Channels | FLTB | |
| $<V_{EN_TH}$ | ISETx open | ISETx pin current close to zero | Device shutdown All channels are off | | High | Off | Enabled | High | Off | Enabled | High | ISETx pin current goes back high |
| | ISETx short | ISETx pin voltage $<V_{ISET_SC}$ | | | | Off | Off | | Off | Enabled | | ISETx pin voltage $>(V_{ISET_SC}+V_{ISET_SCHY})$ |
| | LED string open | $(V_{ICC}-V_{OUTx})<V_{OD}$ | | | | Off | Off | | Off | Enabled | | $(V_{ICC}-V_{OUTx})>(V_{OD}+V_{OD_HY})$ |
| | OUTx short to GND | $V_{OUTx}<V_{SCD}$ | | | | Reserve 4mA for recovery detection | Off | | Enabled | Enabled | | $V_{OUTx}>(V_{SCD}+V_{SCD_HY})$ |
| | Thermal shutdown | $T_J>T_{SD}$ | | | | All channels are off | | | All channels are off | | | $T_J<(T_{SD}-T_{HY})$ |
| $>V_{EN_TH}$ | ISETx open | ISETx pin current close to zero | Off | Off | Pull low after delay time $t_{FLT.D.}$ | Off | Enabled | High | Off | Enabled | High | ISETx pin current goes back high |
| | ISETx short | ISETx pin voltage $<V_{ISET_SC}$ | Off | Off | | Off | Off | Pull low after delay time $t_{FLT.D.}$ | Off | Enabled | Pull low after delay time $t_{FLT.D.}$ | ISETx pin voltage $>(V_{ISET_SC}+V_{ISET_SCHY})$ |
| | LED string open | $(V_{ICC}-V_{OUTx})<V_{OD}$ | Off | Off | | Off | Off | Enabled | Enabled | Enabled | $(V_{ICC}-V_{OUTx})>(V_{OD}+V_{OD_HY})$ | |
| | OUTx short to GND | $V_{OUTx}<V_{SCD}$ | Reserve 4mA for recovery detection | Off | | Reserve 4mA for recovery detection | Off | Enabled | Enabled | Enabled | $V_{OUTx}>(V_{SCD}+V_{SCD_HY})$ | |
| | Thermal shutdown | $T_J>T_{SD}$ | All channels are off | | | All channels are off | | | All channels are off | | | $T_J<(T_{SD}-T_{HY})$ |

IS32LT3124A/B/C/D/E/F QUAD CHANNEL LINEAR LED DRIVER

PCB LAYOUT

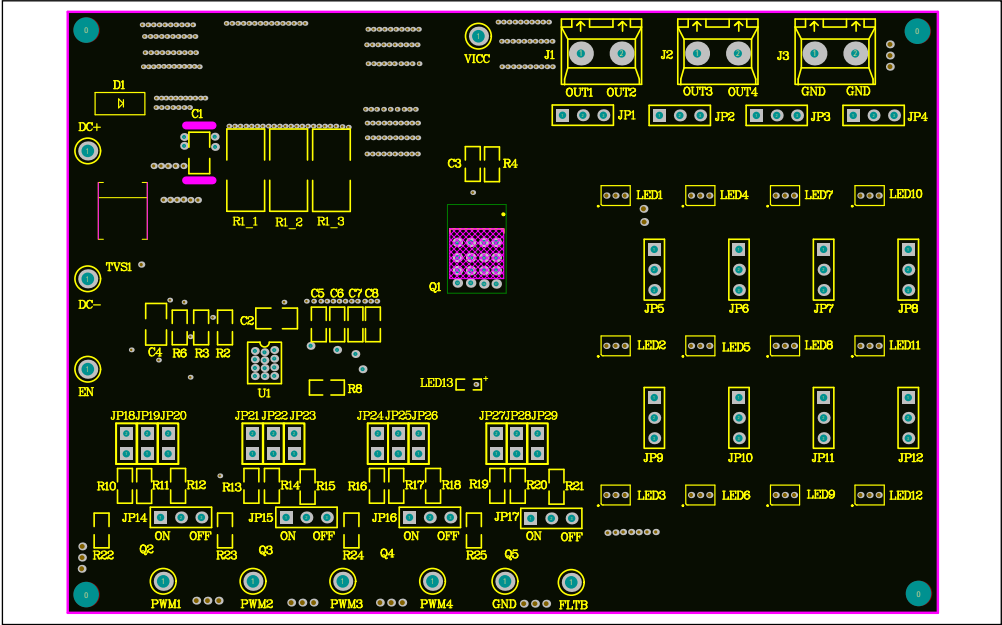

Figure 7: Board Component Placement Guide - Top Layer

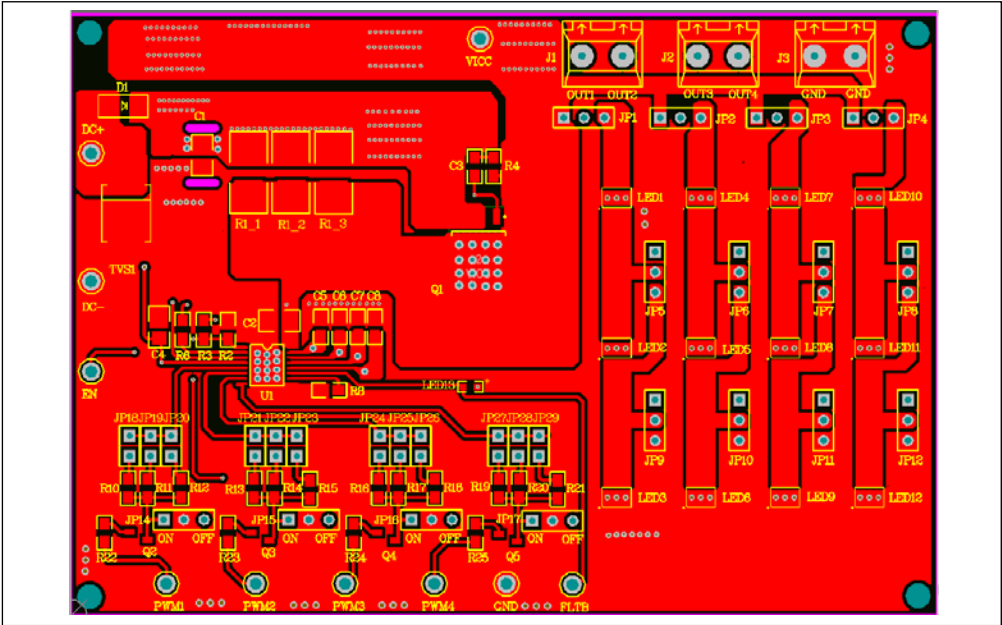

Figure 8: Board PCB Layout - Top Layer

IS32LT3124A/B/C/D/E/F QUAD CHANNEL LINEAR LED DRIVER

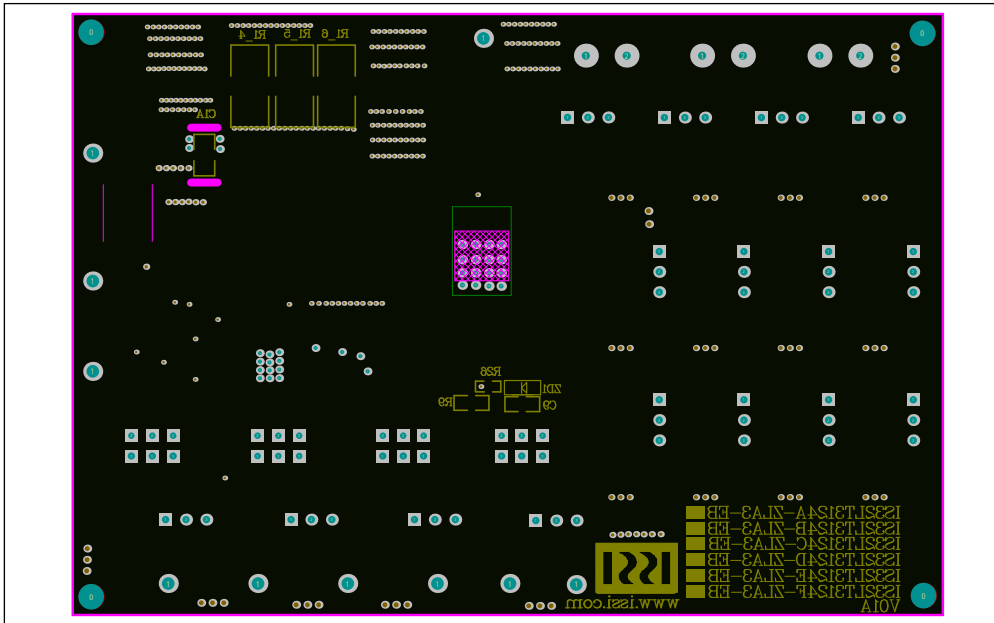

Figure 9: Board Component Placement Guide - Bottom Layer

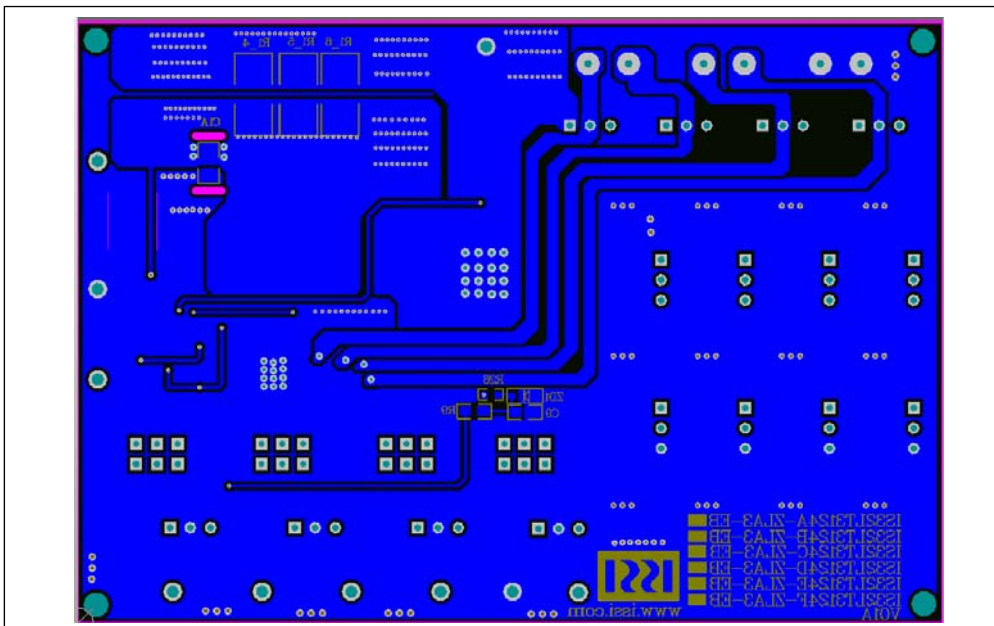

Figure 10: Board PCB Layout - Bottom Layer

Copyright © 2019 Lumissil Microsystems. All rights reserved. Lumissil Microsystems reserves the right to make changes to this specification and its products at any time without notice. Lumissil Microsystems assumes no liability arising out of the application or use of any information, products or services described herein. Customers are advised to obtain the latest version of this device specification before relying on any published information and before placing orders for products.

Lumissil Microsystems does not recommend the use of any of its products in life support applications where the failure or malfunction of the product can reasonably be expected to cause failure of the life support system or to significantly affect its safety or effectiveness. Products are not authorized for use in such applications unless Lumissil Microsystems receives written assurance to its satisfaction, that:

- a.) the risk of injury or damage has been minimized;
- b.) the user assume all such risks; and
- c.) potential liability of Lumissil Microsystems is adequately protected under the circumstances